

Rev. 11/16/18

Features & Options

- Detection Within 5 Seconds with Local LED Alarm Indication
- 0.5 Amp Relay Output @ 30VAC/DC
- One Piece, Rope or Remote Sensor Design
- Adjustable Detection Level with Bottom or Pan Edge Mounting
- 24VAC ±10% Power
- NEMA 4 Enclosure

The Water Leak Detector is designed to sense the presence of water and alert a central monitoring system of the potentially destructive situation. Upon water detection, the alarm relays change state, and a local red LED illuminates. The transmitter can be set for latching or non-latching alarm, and normally energized or normally de-energized operation.

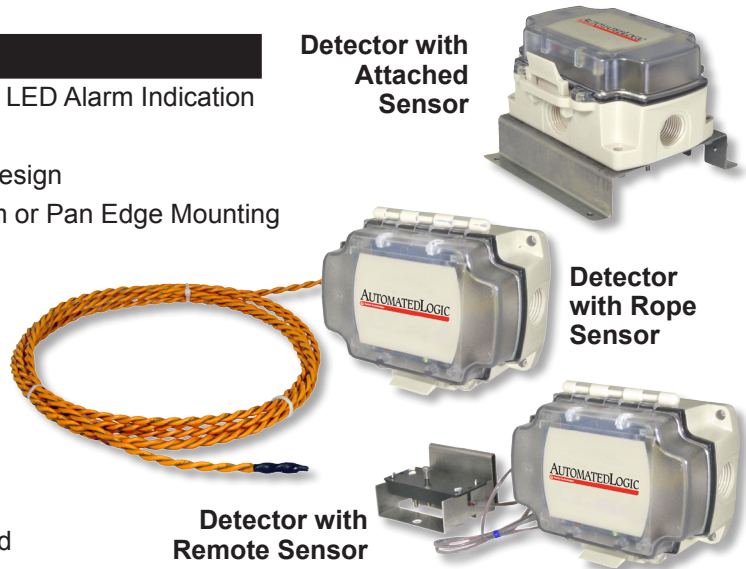

Specifications

Power:	24VAC/VDC +/- 10%
Wiring:	Flex Connector or Liquid Tight Fitting
Relays	Up to 6 wires for Alarm Contacts
Transmitter	2 wires for Power
Mounting:	Lays in the pan with industrial adhesive tape or attached to the pan edge with screws
Sensor:	
Standard	Attached SS probe w/ adjustable depth screw from .063" to .84"
Optional	Remote Sensor w/ adjustable depth from 0.062 to 0.5", Mounting to pan with industrial adhesive tape or 0.172" mounting holes
Optional	Remote Long Line Wire Sensor (Rope), Plenum Rated. Detects 1/8" of water over the full length. Comes in 10, 25, 50 or 100 ft lengths.
Detector Transmitter:	
Alarm Contacts	LDT1: One SPST, 0.5A relay output, 10W max. LDT2: Two SPST, 0.5A relay outputs, 10W max.
Indication	1 Green Power LED, 1 Red Alarm LED
Reset Action	If latching, local push button or power interrupt
Termination:	Terminal strip, 12 to 24 AWG
Latching and Supervised Relay Options:	
Latching	Relay stays in alarm until manually reset or power is cycled
Non-Latching	Relay automatically resets after water has dried up (default)
Unsupervised	Relay energizes on water detection
Supervised	Relay de-energizes on water detection (default) Note: Relay de-energizes on loss of power
Enclosure Ratings:	
Remote Sensor	Submersible, with FEP plenum-rated, waterproof cable
Detector	BAPI-Box, NEMA 4
Ambient:	
Remote Sensor	-40 to 185°F (-40 to 85°C), 0 to 100%RH, Condensing
Rope Sensor	32 to 167°F (0 to 75°C), 0 to 95%RH, Non-condensing
Detector (BB)	-40 to 185°F (-40 to 85°C), 0 to 95%RH, Non-condensing
Materials:	Sensor: Stainless Steel BAPI-Box: Polycarbonate
Agency:	RoHS, UL94V-0, UV-rated in Enclosure

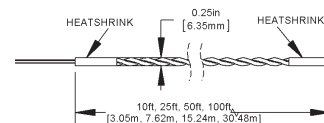
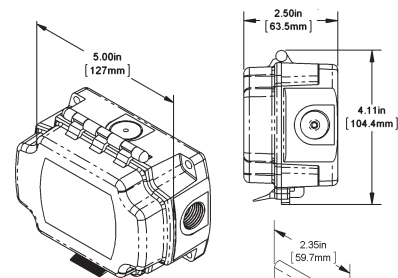
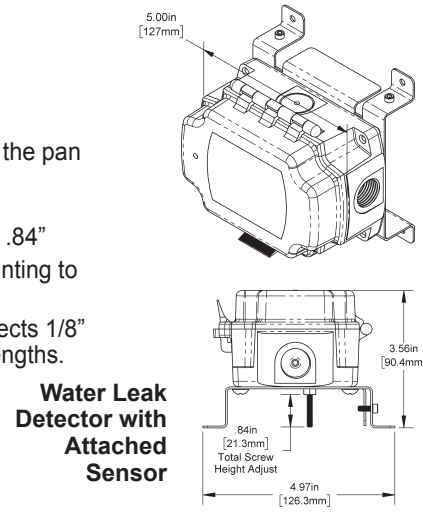

Ordering Information/Part Numbers

UNITS WITH BUILT IN SENSOR

ALC/LDT1-PS-BB One 0.5A SPST relay output and built in sensor

ALC/LDT1-PS-BB-LTF ... One 0.5A SPST relay output and built in sensor, Liquid Tight Fitting

ALC/LDT1-PS-BB-GFF .. One 0.5A SPST relay output and built in sensor, Flex Connector

ALC/LDT2-PS-BB Two 0.5A SPST relay outputs and built in sensor

ALC/LDT2-PS-BB-LTF ... Two 0.5A SPST relay outputs and built in sensor, Liquid Tight Fitting

ALC/LDT2-PS-BB-GFF .. Two 0.5A SPST relay outputs and built in sensor, Flex Connector

UNITS WITH REMOTE SENSOR

ALC/LDT1-RS5-BB One 0.5A SPST relay output, remote sensor, 5' FEP cable

ALC/LDT1-RS5-BB-LTF One 0.5A SPST relay output, remote sensor w/ 5' FEP cable, Liquid Tight Fitting

ALC/LDT1-RS5-BB-GFF One 0.5A SPST relay output, remote sensor w/ 5' FEP cable, Flex Connector

ALC/LDT2-RS5-BB Two 0.5A SPST relay outputs, remote sensor, 5' FEP cable

ALC/LDT2-RS5-BB-LTF Two 0.5A SPST relay outputs, remote sensor w/ 5' FEP cable, Liquid Tight Fitting

ALC/LDT2-RS5-BB-GFF Two 0.5A SPST relay outputs, remote sensor w/ 5' FEP cable, Flex Connector

Note: 10 and 25 foot FEP cables are available for the remote sensor units. To order these cables, change the -RS5 in the part number to -RS10 for the 10' cable or to -RS25 for the 25 foot cable.

UNITS WITH REMOTE ROPE SENSOR

ALC/LDT1-RR10-BB

One 0.5A SPST relay output, remote rope sensor with 10 foot plenum-rated cable

ALC/LDT1-RR10-BB-LTF

One 0.5A SPST relay output, remote rope sensor with 10 foot plenum-rated cable, Liquid Tight Fitting

ALC/LDT1-RR10-BB-GFF

One 0.5A SPST relay output, remote rope sensor with 10 foot plenum-rated cable, Flex Connector

ALC/LDT2-RR10-BB

Two 0.5A SPST relay outputs, remote rope sensor with 10 foot plenum-rated cable

ALC/LDT2-RR10-BB-LTF

Two 0.5A SPST relay outputs, remote rope sensor with 10 foot plenum-rated cable, Liquid Tight Fitting

ALC/LDT2-RR10-BB-GFF

Two 0.5A SPST relay outputs, remote rope sensor with 10 foot plenum-rated cable, Flex Connector

Note: 25, 50 and 100 foot cables are available for the remote rope sensor units. To order these cables, change the -RR10 in the part number to -RR25 for the 25' cable, to -RR50 for the 50' cable and to RR100 for the 100' cable.

