

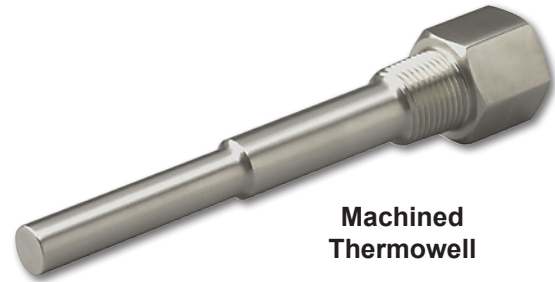

Features & Options

- Three Lengths: 2", 4" and 8"
(Fit standard Immersion Unit lengths)
- Stainless Steel (304 or 316) or Brass
- Other Lengths Available Upon Request
- Limited Lifetime Warranty



Machined Thermowell

Standard Thermowells available from BAPI include machined 304 stainless steel, 316 stainless steel, brass. These wells are offered in 2", 4" and 8" lengths with 1/2" NPT external and 1/2" NPSM internal. Other lengths and thread diameters are available upon request.

The Thermowell chosen for an installation is governed mainly by the corrosion conditions the well will face. The machined stainless steel wells all come with a mirror polish to provide maximum corrosion resistance.

Occasionally, the material consideration is one of strength rather than corrosion. For example, a machined stainless steel well may be required for high pressure water service where otherwise a brass thermowell would be satisfactory from a corrosion standpoint.

Specifications

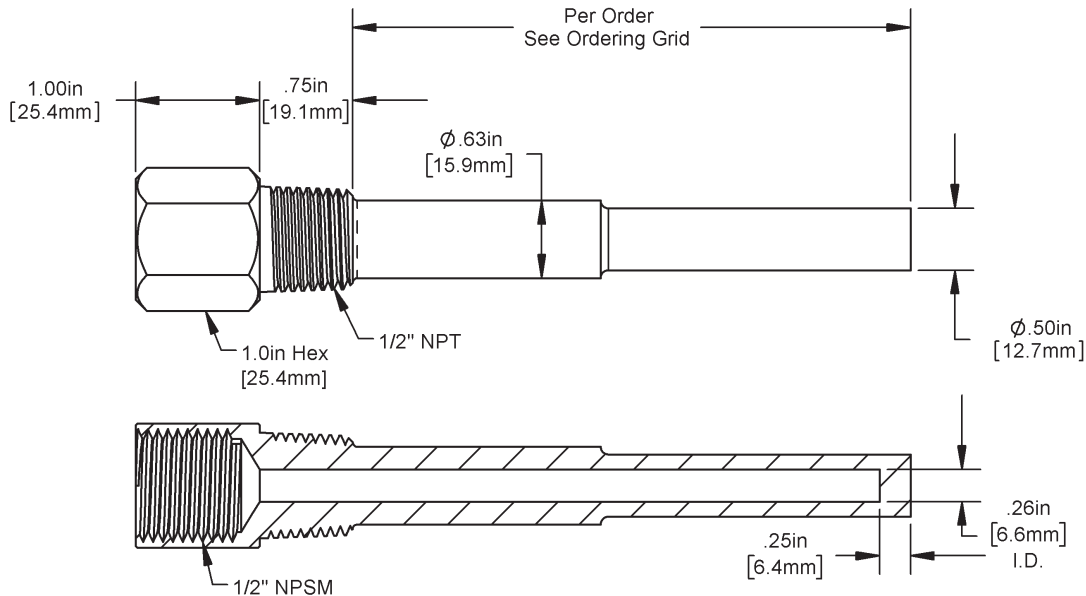

NPT= National Pipe Taper
NPSM=National Pipe Straight Mechanical (not tapered)





Submittal sheets without List Prices are available on our website at www.bapihvac.com

Ordering Information

Part #	Description	List Price
BA/2" M304	Machined 304 Stainless Steel - 2"	\$24
BA/4" M304	Machined 304 Stainless Steel - 4"	\$30
BA/8" M304	Machined 304 Stainless Steel - 8"	\$46
BA/2" M316	Machined 316 Stainless Steel - 2"	\$44
BA/4" M316	Machined 316 Stainless Steel - 4"	\$50
BA/8" M316	Machined 316 Stainless Steel - 8"	\$80
BA/2" MB	Machined Brass - 2"	\$23
BA/4" MB	Machined Brass - 4"	\$26
BA/8" MB	Machined Brass - 8"	\$45

Note: Standard thread size is 1/2" NPT external, and 1/2" NPSM internal. 2" units have an insertion length of 2.5" (5.1 cm). 4" units have an insertion length of 4.5" (11.43 cm). 8" units have an insertion length of 7.5" (19.05 cm).

Gray shaded items follow the Buy and Resale Multiplier.



Comparing the Wake Frequency and the Resonant Frequency

Thermowell failures, in most cases, are not due to the effects of pressure or temperature on the thermowell. The calculations necessary to provide adequate strength, under given conditions, are familiar enough to permit proper choice of wall thickness and material. The values shown in Table 1 are conservative, and intended primarily as a guide.

Less familiar, and more dangerous, are the **vibration effects** to which thermowells are subjected. Fluid, flowing by the thermowell, forms a turbulent wake (called the Von Karman Trail) which has a definite frequency, based on the diameter of the thermowell and the velocity of the fluid. It is important that the thermowell have sufficient stiffness so that the wake frequency will never equal the resonant (natural) frequency of the thermowell itself. If the resonant frequency of the thermowell coincided with the wake frequency, the thermowell would vibrate to destruction and break off in the piping. Thermowells are also safe if the resonant frequency is thermowell **below** the wake frequency or if the fluid velocity is constantly fluctuating through the critical velocity point.

Nevertheless, if the installation is not hampered by the use of a sufficiently stiff thermowell, we recommend the values given in Table 2 not be exceeded.

Table 1: Pressure Rating versus Temperature

Thermowell Material	Temperature in Degrees Fahrenheit						
	70°F	200°F	400°F	600°F	800°F	1000°F	1200°F
	Pressure Rating (Pounds per Square Inch)						
Brass	5000	4200	1000	-	-	-	-
304 S.S.	7000	6200	5600	5400	5200	4500	1650
316 S.S.	7000	7000	6400	6200	6100	5100	2500

Table 2: Maximum Fluid Velocity versus Insertion Length

Thermowell Material	Fluid Type	Insertion Length (inches)		
		1-2"	1-4"	1-8"
		Maximum Fluid Velocity (Feet per Second)		
Brass	Air/Steam	207	75.5	27.3
	Water	59.3	32.2	19.7
304 S.S.	Air/Steam	300	109	39.5
316 S.S.	Water	148	82.2	-

The values shown in Table 2 are based on operating temperatures of 350°F for brass and 1,000°F for 304 and 316 stainless steel (S.S.). Slightly higher velocities are possible at lower temperatures.

