



# BAPI-Stat “Quantum Slim” Wireless Temperature or Temp/Humidity Sensor

Installation & Operations

49524\_Wireless\_BLE\_Quantum\_Slim\_Temp\_Hum

rev. 03/13/24

## Overview and Identification

- Built in or remote temperature sensor
- User adjustable settings via receiver or WAM
- Onboard memory to store readings
- Transmits to a digital Gateway or a wireless-to-analog Receiver

The BAPI-Stat “Quantum Slim” Wireless Sensor measures the temperature or Temp/Humidity and transmits the data via Bluetooth Low Energy to a receiver or gateway.

The units are perfect for refrigerator and freezer cases. The sensor body mounts on the outside of freezers, and either inside or outside of refrigerators. It is available with an internal sensor or an external probe or thermobuffer. The external cable fits between the door seal or through a hole without affecting appliance efficiency.

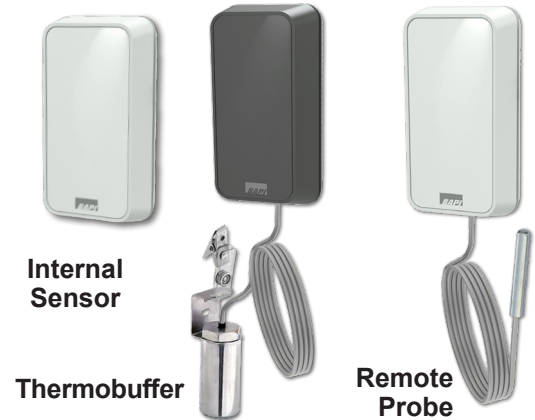

## Adjustable Settings

BAPI’s wireless devices have several settings that can be field adjusted to suit the needs of the installation. All settings are configured by either BAPI’s cloud based Wireless Asset Monitoring (WAM) or the receiver. (See the WAM or receiver instructions documents available on the BAPI website for more information on adjusting the settings.)

**Sample Rate/Interval** – The time between when the sensor wakes up and takes a reading. The available values are 1 min or 5 min with the gateway, or 30 sec, 1 min, 3 min or 5 min with the receiver.

**Transmit Rate/Interval** – The time between when the sensor transmits the readings to the gateway or receiver. The available values are 1, 2, 3, 4, 5, 10, 15, 20 or 30 minutes, or 1, 6 or 12 hours with the gateway, or 1, 5, 10 or 30 minutes with the receiver.

**Delta  $\Delta$  Temperature** – The change in temperature between a sample and the last transmission that will cause the sensor to override the transmit interval and immediately transmit the changed temperature. The available values are 0.1, 0.2, 0.3, 0.4, 0.5, 1, 2, 3, 4, 5 °F or °C with the gateway, and 1 or 3 °F or °C with the receiver.

**Delta  $\Delta$  Humidity** – The change humidity between a sample and the last transmission that will cause the sensor to override the transmit interval and immediately transmit the changed humidity. The available values are 0.5, 1, 2, 3, 4 or 5 %RH with the gateway, and 3 or 5 %RH with the receiver.

**Temperature Min/Max** – The maximum or minimum temperature that will cause the sensor to override the transmit interval and immediately transmit a reading to the gateway. (Only available when using a gateway.)

**Temperature Offset** – Adjusts the temperature value being transmitted to match that of a calibrated reference device. The available values are  $\pm 0.1$ , 0.2, 0.5, 1, 2, 3, 4 or 5 °F or °C. (Only available when using a gateway.)

**Humidity Offset** – Adjusts the humidity value being transmitted to match that of a calibrated reference device. The available values are  $\pm 0.5$ , 1, 2, 3 or 5 %RH. (Only available when using a gateway.)

## Associated Receiver or Gateway

### RECEIVER (Wireless-to-Analog)

The wireless receiver from BAPI receives the data from one or more wireless sensors. The data is then transferred to the analog output modules and converted to an analog voltage or resistance. The receiver supports up to 32 sensors and up to 127 different analog output modules.



### GATEWAY

The wireless gateway receives the data from one or more wireless sensors. The gateway then provides the data to the cloud via MQTT. The gateway also sends a confirmation signal to each sensor upon a successful reception of data. The gateway supports up to 32 sensors.



See BAPI’s gateway instructions on the BAPI website ([www.bapihvac.com/wp-content/uploads/50387\\_Wireless\\_BLE\\_Gateway.pdf](http://www.bapihvac.com/wp-content/uploads/50387_Wireless_BLE_Gateway.pdf)) to establish communication between the sensors and gateway or the receiver instructions ([www.bapihvac.com/wp-content/uploads/50335\\_Wireless\\_BLE\\_Receiver\\_AOM.pdf](http://www.bapihvac.com/wp-content/uploads/50335_Wireless_BLE_Receiver_AOM.pdf)) to establish communication between the sensors and receiver.

### Initial Activation

For convenience, BAPI recommends pairing the sensor to the intended receiver or gateway prior to mounting either device. Both devices need to be powered-on to pair. See the receiver or gateway installation manual for instructions on pairing the sensor.

The unit comes with a pre-installed battery. To activate the unit, remove the base plate and pull out the battery insulator tab as shown in Fig. 1. Press the Service button and the Service LED should flash once to confirm power. If the sensor will not be commissioned for more than a couple of days, BAPI recommends reinstalling the battery insulator tabs to conserve battery life.

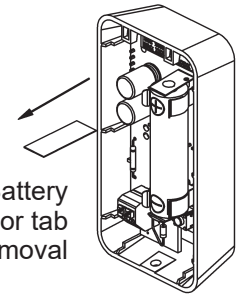
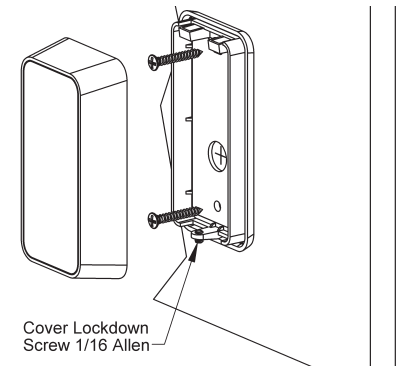

**Fig. 1:** Battery insulator tab removal

### Drywall Mounting

1. Place the base plate vertically against the wall where you want to mount the sensor and mark the two mounting holes.
2. Drill two 3/16” (4.8mm) holes in the center of each marked mounting hole. Insert a drywall anchor into each hole.
3. Secure the base to the drywall anchors using the #6 x 1” (25mm) mounting screws provided.
4. Attach Cover by latching it to the top of the base, rotating the cover down and snapping it into place. Secure the cover by backing out the lock-down screw using a 1/16” (1.6mm) Allen wrench until it is flush with the bottom of the cover.

**Fig. 2:** BAPI-Stat “Quantum Slim” Mounting



Cover Lockdown Screw 1/16 Allen

### Probe or Thermobuffer Mounting

Mount the External Probe using a Flexible Probe Bracket (Fig. 3) or use the clip or screw hole on the Hanging Bracket Sensor (Fig. 4)

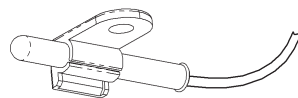

**Fig. 3:** External Probe Mounting with a Flexible Probe Bracket (BA/FPB)

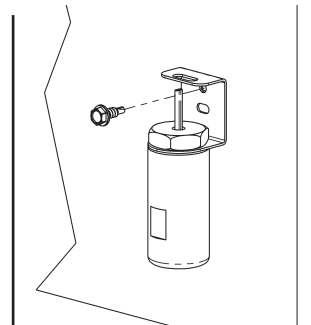

**Fig. 4:** External Hanging Bracket Sensor Mounting

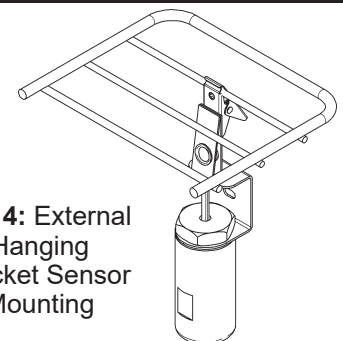

### Operation

Power the unit as described in “Initial Activation” section. Follow the gateway or receiver instructions for pairing the unit and changing the adjustable settings. (The instructions are available on the BAPI website.)

Green LED flashes when the “Service” button is pressed or during the pairing process.

**Fig. 5:** BAPI-Stat “Quantum Slim” Circuit Board

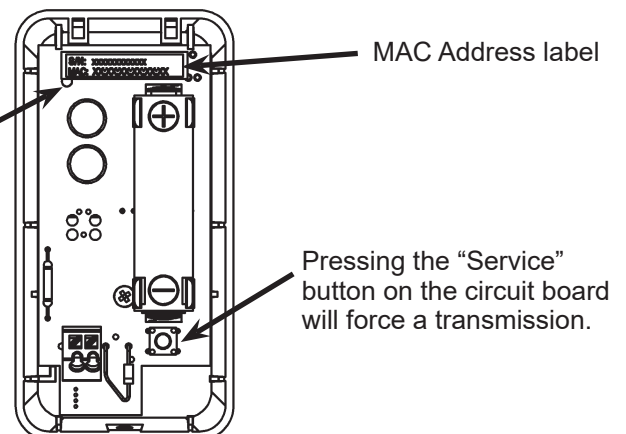

Pressing the “Service” button on the circuit board will force a transmission.

### Wireless Sensor Reset

Sensors remain paired to the gateway or receiver and output modules when power is interrupted or the batteries are removed. To break the bonds between them, the sensors need to be reset. To do this, press and hold the “Service Button” on the sensor for about 30 seconds. During those 30 seconds, the green LED will be off for about 5 seconds, then flash slowly, then begin flashing rapidly. When the rapid flashing stops, the reset is complete. The sensor can now be paired to a new receiver or gateway. To re-pair to the same receiver or gateway, you must reset the receiver or gateway. Output modules that were previously paired to the sensor do not need to be re-paired.

### Onboard Memory

Sensor retains up to 16,000 readings should the communication become interrupted. The sensor only stores readings from missed transmissions and only when the sensor is paired to a gateway. Once communication is re-established with the gateway, the stored readings are transmitted and then erased from the sensor. The current reading and nine previous readings are sent at each transmit interval until the sensor is caught up. Temporarily shortening the transmit interval will allow the sensor to more quickly clear any stored readings.

### Battery Replacement

1. Remove the cover from the base plate by turning in the cover lockdown screw with a 1/16” (1.6mm) Allen wrench until the cover can be removed.
2. Remove the used battery from its holder and discard in an environmentally safe manner. Replace with a new battery in the correct orientation (Fig 6).
3. Attach Cover by latching it to the top of the base, rotating the cover down and snapping into place. Secure the cover by backing out the lock-down screw using a 1/16” (1.6mm) Allen wrench until it is flush with the bottom of the cover.

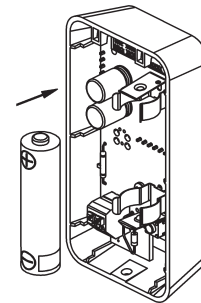

Fig. 6:  
Battery  
replacement

**Battery Specs:** One 3.6V Lithium batteries: (#14505, 14500 or equivalent)

### Door Switch Magnet Accessory

The Door Switch Magnet (**BA/DSM**) works with BAPI’s Wireless “Quantum Slim” sensor to monitor the status of doors, including refrigerators, freezers, outside doors and garbage gates. The pickup for the Door Switch Magnet is already mounted inside all of the BAPI-Stat “Quantum Slim” units, including those with external sensors.



Mount the magnet on the door so that when the door is closed, the magnet is within 0.4” (10mm) of the lower, right side of the “Quantum Slim”. The magnet can be mounted with double-sided mounting tape or with screws in the mounting holes.

The output from the BAPI-Stat “Quantum Slim” is a digital “On/Off” signal to the gateway or the receiver. The switch is “off” when the magnet is within 0.4” (10mm) of the “Quantum Slim” and “on” when it is not.

**Note:** When used with the receiver, the Door Switch Magnet requires a Relay Output Module to convert the signal to an open or closed relay signal for the controller input. This Relay Output Module is not available at present but is coming soon.

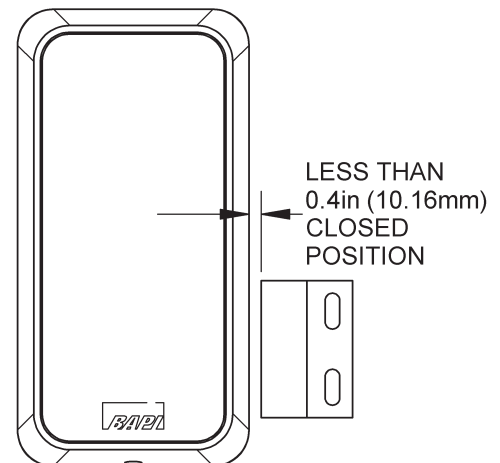

Fig. 7: Door Switch Magnet Mounting

### Diagnostics

#### Possible Problems:

Sensor is not communicating with the gateway or receiver, or the transmitted values are incorrect.

#### Possible Solutions:

Make sure the sensor is within range of the gateway or receiver.

Verify that the green LED on the sensor circuit board flashes when the “Service” button is pressed, indicating a transmission. If it does not flash, replace the battery.

Verify that the sensor is properly paired to the gateway or receiver and analog output modules as described in the gateway or receiver instructions available on the BAPI website. Re-pair them if needed. If necessary, perform the “Wireless Sensor Reset” procedure described above.



# BAPI-Stat "Quantum Slim" Wireless Temperature or Temp/Humidity Sensor

Installation & Operations

49524\_Wireless\_BLE\_Quantum\_Slim\_Temp\_Hum

rev. 03/13/24

## Specifications

**Battery Power:** One included 3.6V 14505, 14500 or equiv. lithium battery (Note: Standard AA batteries are not compatible)

**Wire Power:** 9 to 30 VDC or 24 VAC, halfwave rectified

**Sensor Accuracy:**

Temp:  $\pm 1.25^{\circ}\text{F}$  ( $0.7^{\circ}\text{C}$ ) from 32 to 158 $^{\circ}\text{F}$  (0 to 70 $^{\circ}\text{C}$ )

Humidity:  $\pm 2\% \text{RH}$  @ 77 $^{\circ}\text{F}$  (25 $^{\circ}\text{C}$ ), 20 to 80%RH

**Temperature Range:** -4 to 221 $^{\circ}\text{F}$  (-20 to 105 $^{\circ}\text{C}$ )

**Transmission Distance:** Varies by application\*

**Environmental Operation Range:**

Temp: -4 to 149 $^{\circ}\text{F}$  (-20 to 65 $^{\circ}\text{C}$ )

Humidity: 10 to 90% RH, non-condensing

**Enclosure Material & Rating:** ABS Plastic, UL94 V-0

**Frequency:** 2.4 GHz (Bluetooth Low Energy)

**Receiver Sensitivity:** -97 dBm

**Ext. Probe Material:** 304 Stainless Steel  
1.75" (44mm) Bullet Probe with FEP Cable  
1" (25mm) Thermobuffer with FEP Cable

**User Adjustable Settings:**

Delta T (Temp): 0.1 $^{\circ}\text{F}/\text{C}$  to 5.0 $^{\circ}\text{F}/\text{C}$

Delta T (Humidity): 0.1%RH to 5.0%RH

Transmit Interval: 30 sec to 12 hour\*\*\*

Sample Interval: 30 sec to 5 min\*\*\*

Temp Offset:  $\pm 0.1^{\circ}\text{F}/\text{C}$  to  $\pm 5.0^{\circ}\text{F}/\text{C}$

Humidity Offset:  $\pm 0.1\% \text{RH}$  to  $\pm 3.0\% \text{RH}$

**Onboard Memory:** Sensor retains up to 16,000 readings should the communication become interrupted. If using a Gateway, the data is re-transmitted once communication is re-established.

**Agency:** RoHS / FCC: T4FSM220923 / IC: 9067A-SM220923

This device complies with Part 15 of the FCC Rules. Operation is subject to the following two conditions:

1. This device may not cause harmful interference, and
  2. This device must accept any interference received, including interference that may cause undesirable operation.
- Any changes or modifications not expressly approved by BAPI could void the user's authority to operate the equipment.

This device complies with Industry Canada (IC) license-exempt RSS standard(s). Operation is subject to the following two conditions.

This device may not cause interference.

This device must accept any interference, including interference that may cause undesired operation of the device.

Le présent appareil est conforme aux CNR d'Industrie Canada applicables aux appareils radio exempts de licence.

L'exploitation est autorisée aux deux conditions suivantes.

L'appareil ne doit pas produire de brouillage.

L'appareil doit accepter tout brouillage radioélectrique subi, même si le brouillard est susceptible d'en compromettre le fonctionnement.

\*In-building range is dependent on obstructions such as furniture and walls and the density of those materials. In wide open spaces, the distance may be greater; in dense spaces, the distance may be less.

\*\*Actual battery life is dependent on the sensor's adjustable settings and environmental conditions.

\*\*\*The available transmit intervals and sample intervals are different depending on whether the system is using a gateway or a receiver.

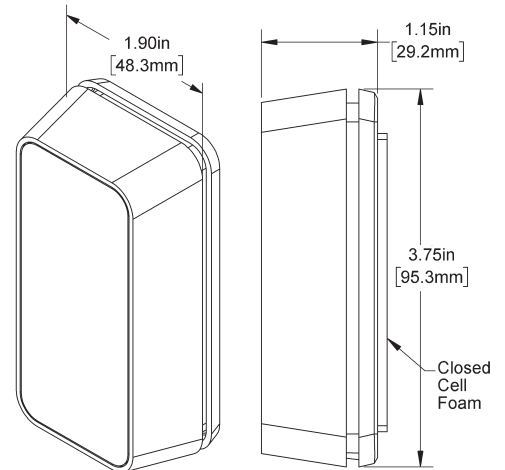

BAPI-Stat "Quantum Slim"

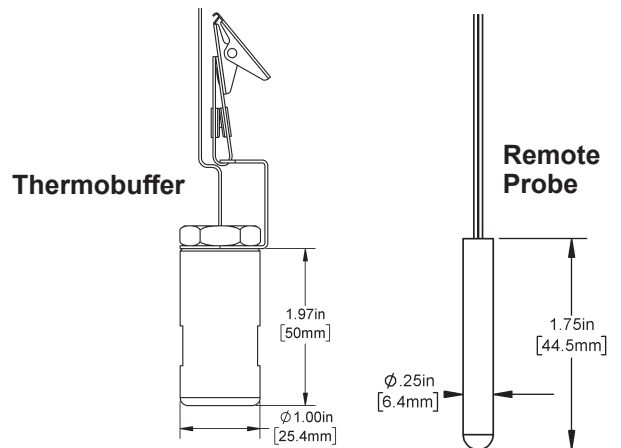

Thermobuffer

Remote Probe

BAPI-Stat "Quantum-Slim" Calculated Battery Life**		
Transmit Interval	Sample Rate	Estimated Life (years)
30 sec	30 sec	0.58
1 min	1 min	1.04
3 min	1 min	2.03
5 min	5 min	3.02
10 min	5 min	4.01

Specifications subject to change without notice.