

## Identification and Overview

The BAPI-Stat “Quantum” Particulate Sensor is an accurate and reliable way of continuously monitoring the concentration of particles in a room. Laser-based sensors provide the highest accuracy for commercial applications and will measure particle concentrations from 0 to 1,000  $\mu\text{g}/\text{m}^3$ .

The sensor uses an internal fan that draws air into the bottom of the enclosure and exhausts it out the top.

The sensor has field selectable outputs of 0 to 5V, 0 to 10V, and 4 to 20mA. The user may select which particulate size to measure to meet the standards for PM1.0, PM2.5, and PM10 requirements.

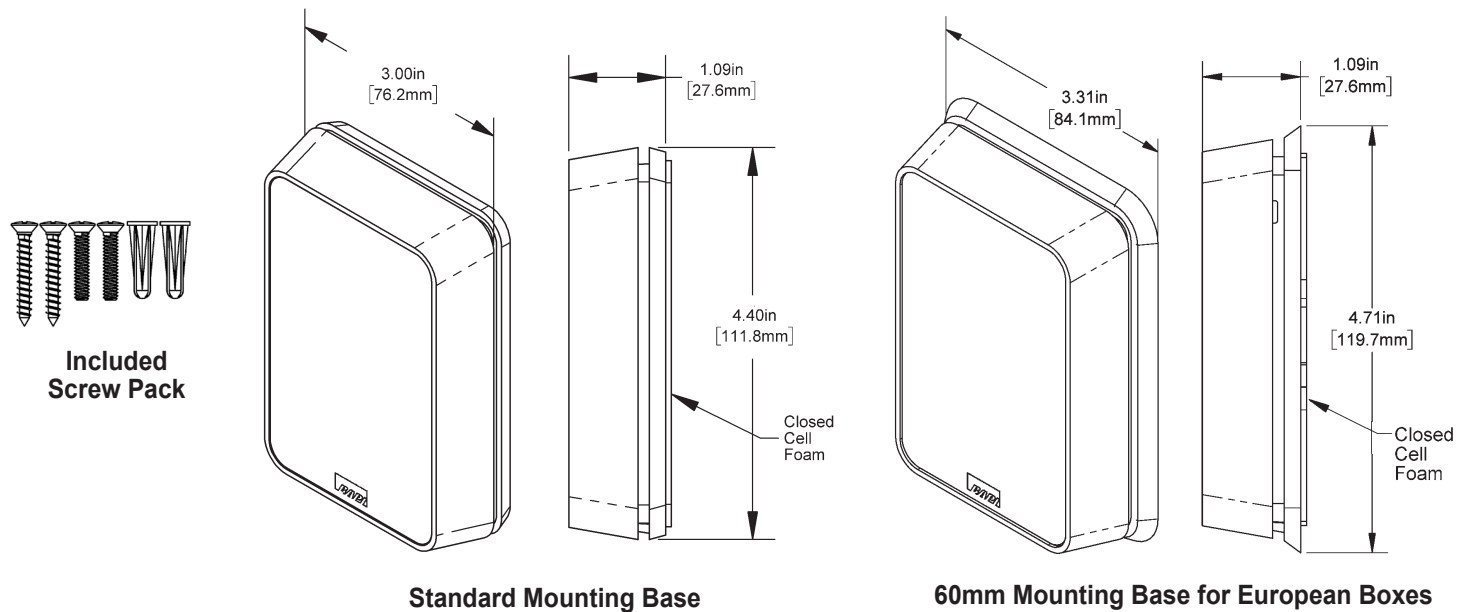

Fig. 1: BAPI-Stat “Quantum” Particulate Sensor

## Specifications

**Power:** (Half-wave rectified)  
 7 to 40 VDC (4 to 20mA Output)  
 7 to 40 VDC or 12 to 28 VAC (0 to 5 VDC Output)  
 15 to 40 VDC or 15 to 28 VAC (0 to 10 VDC Output)

**Power Consumption:**  
 75 mA Max @ 24 VDC • 3 VA Max @ 24 VAC

**Load Resistance:** VDC Output 4K Ohms Min

**Sensing Element:** Laser-based, Light Scattering

**Sensor Element Life:** 10 Years Typical

**Concentration Range:** 0 to 1,000  $\mu\text{g}/\text{m}^3$

**Accuracy at 77°F (25°C):**

	0 to 100 $\mu\text{g}/\text{m}^3$	100 to 1,000 $\mu\text{g}/\text{m}^3$
PM1.0	$\pm 25 \mu\text{g}/\text{m}^3$	$\pm 25\%$ of reading
PM2.5	$\pm 15 \mu\text{g}/\text{m}^3$	$\pm 15\%$ of reading
PM10	$\pm 25 \mu\text{g}/\text{m}^3$	$\pm 25\%$ of reading

**Response Time:**  
 <6 Seconds

**Wiring:**  
 3 Wires, 16 to 22 AWG

**Environmental Operating Range:**  
 -4 to 158°F (-20 to 70°C)  
 0 to 95%RH Non-condensing

**Enclosure Material:**  
 ABS Plastic, UL94, V-0

**Mounting:**  
 Standard 2”x4” Junction Box, European Junction Box or  
 Drywall Mount (screws provided)

**Agency:**  
 CE EN 61326-1:2013 EMC, UL, RoHS

Specifications subject to change without notice.

### Mounting

Mounting hardware is provided for both junction box and drywall installation (junction box installation shown).

Note: Screw the 1/16" Allen lock-down screw into the base to open the case. Back out the lock-down screw to secure the cover.

#### Junction Box

1. Pull the wire through the wall and out of the junction box, leaving about six inches free.
2. Pull the wire through the hole in the base plate.
3. Secure the plate to the box using the #6-32 x 5/8 inch mounting screws provided.
4. Terminate the unit according to the guidelines in the Termination section. (page 3)
5. Mold the foam on the unit's base to the wire bundle to prevent drafts. (see note below)
6. Attach cover by latching it to the top of the base, rotating the cover down and snapping it into place.
7. Secure the cover by backing out the lock-down screw using a 1/16" Allen wrench until it is flush with the bottom of the cover.

#### Drywall Mounting

1. Place the base plate against the wall where you want to mount the sensor. Mark out the two mounting holes and the area where the wires will come through the wall.
2. Drill two 3/16" (5mm) holes in the center of each marked mounting hole. Insert a drywall anchor into each hole.
3. Drill one 1/2" (13mm) hole in the middle of the marked wiring area.
4. Pull the wire through the wall and out of the 1/2" hole, leaving about six inches free. Pull the wire through the hole in the base plate.
5. Secure the base to the drywall anchors using the #6 x 1 inch mounting screws provided.
6. Terminate the unit according to the guidelines in the Termination section. (page 3)
7. Mold the foam on the unit's base to the wire bundle to prevent drafts. (see note below)
8. Attach cover by latching it to the top of the base, rotating the cover down and snapping it into place.
9. Secure the cover by backing out the lock-down screw using a 1/16" Allen wrench until it is flush with the bottom of the cover.



**IMPORTANT:** The mixing of room air and air from within the wall cavity can lead to condensation, erroneous readings and sensor failure. To prevent these conditions, BAPI recommends sealing the conduit leading to the junction box, filling the junction box with fiberglass insulation or sealing the wall cavity. Do not use silicone sealants as the fumes may produce a film on the sensing element.

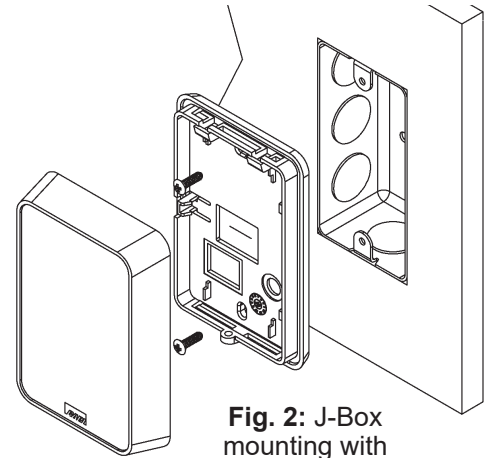

Fig. 2: J-Box mounting with standard base

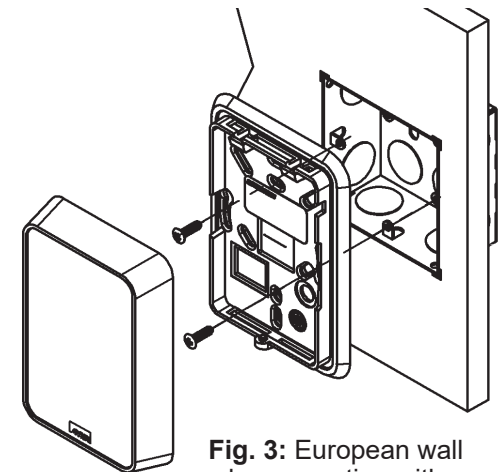

Fig. 3: European wall box mounting with 60mm base

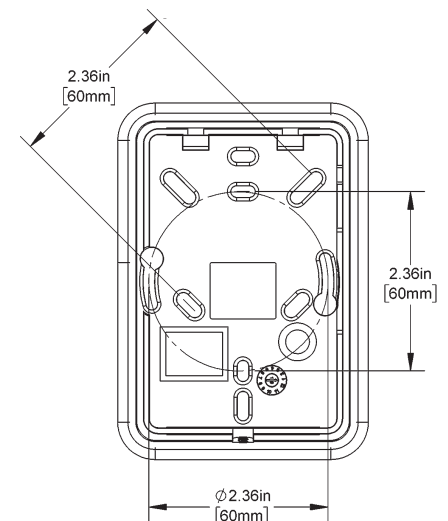
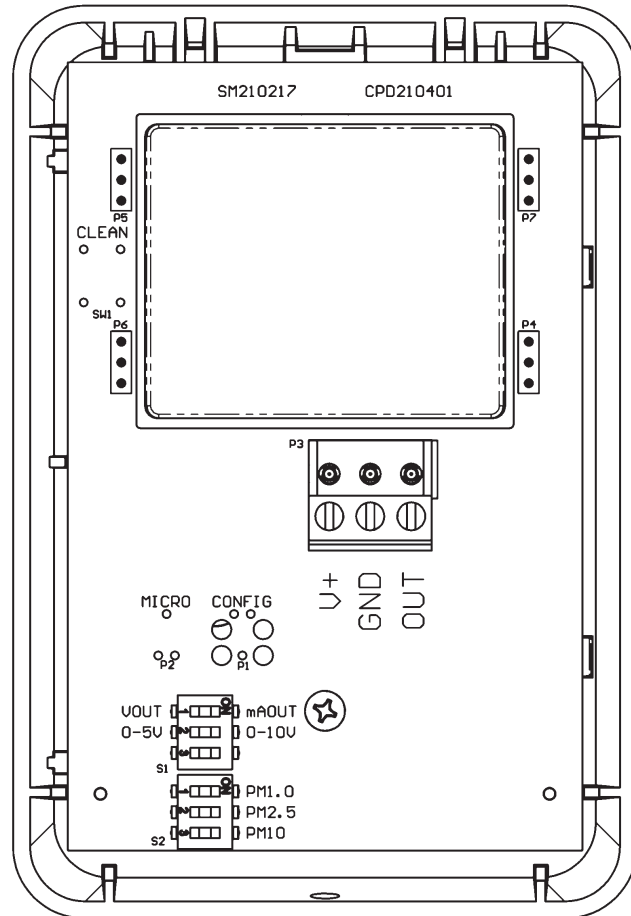

Fig. 4: 60mm mounting base dimensions

## Termination

BAPI recommends using twisted pair of at least 22AWG for all wire connections. Larger gauge wire may be required for long runs. All wiring must comply with the National Electric Code (NEC) and local codes. Do NOT run this device's wiring in the same conduit as AC power wiring of NEC class 1, NEC class 2, NEC class 3 or with wiring used to supply highly inductive loads such as motors, contactors and relays. BAPI's tests show that fluctuating and inaccurate signal levels are possible when AC power wiring is present in the same conduit as the signal lines. If you are experiencing any of these difficulties, please contact your BAPI representative.



BAPI recommends wiring the product with power disconnected. Proper supply voltage, polarity, and wiring connections are important to a successful installation. Not observing these recommendations may damage the product and will void the warranty.

<b>Terminal</b>	<b>Function</b>
<b>V+</b> .....	From power supply, see Specifications for requirements.
<b>GND</b> .....	To controller Ground [GND or Common]
<b>OUT</b> .....	Voltage and mA Outputs, Particulate Signal, Referenced to GND

**Note:** Terminal block is pluggable

**Fig. 5:**  
Circuit Board

## Switch S1 & S2 Setup: Outputs & Ranges

Switch settings may be changed at any time.

### DIP Switch S1:

- Select the Output  
 VOUT = Voltage  
 mAOUT = 3-Wire Transmitter
- Select the voltage range for VOUT.  
 0-5V = 0 to 5V Output  
 0-10V = 0 to 10V Output  
 If "mAOUT" is selected in Step 1, this setting does not matter.
- Switch #3 is not used.

### DIP Switch S2:

- Select the particulate size by moving the switch to "ON".  
 PM1.0 =  $\leq 1.0 \mu\text{m}$  diameter  
 PM2.5 =  $\leq 2.5 \mu\text{m}$  diameter  
 PM10 =  $\leq 10 \mu\text{m}$  diameter
- Only 1 of the 3 switches may be set to "ON". If none of the switches or more than 1 switch is set to "ON", the sensor's output will alternate between 50% and 100% of the output setting to indicate the error.

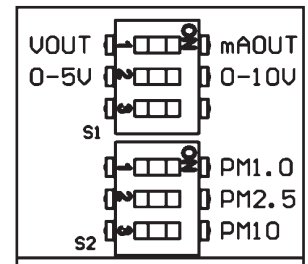

**Fig. 6:** DIP Switches S1 and S2



# Particulate Sensor in a BAPI-Stat Quantum

Installation and Operating Instructions

47499\_ins\_BSQ\_Part particulate

rev. 07/28/21

## Output Validation

A simple bump test is performed to validate that the sensor responds to elevated particulate levels.

1. "Smoke in a can" type products, which are often used to test smoke detectors, are a good option for testing all 3 particulate sizes. Cigarette smoke and incense smoke also work, but the particulate size may be too large to be measured on the PM1.0 setting.
2. Spray the smoke in a can at the bottom of the BAPI-Stat "Quantum" enclosure for 1 to 2 seconds to flood the sensor with smoke.
3. After several seconds, the sensor's output will increase. It may take several minutes for the sensor's output to decrease to normal levels as the smoke dissipates.

## Diagnostics

### Possible Problems:

General troubleshooting

### Possible Solutions:

Determine that the input is set up correctly in the controller's and building automation software.

Check wiring at the sensor and controller for proper connections.

Check for corrosion at either the controller or the sensor. Clean off the corrosion, re-strip the interconnecting wire and reapply the connection. In extreme cases, replace the controller, interconnecting wire and/or sensor.

Check the wiring between the sensor and controller. Label the terminals at the sensor end and the controller end. Disconnect the interconnecting wires from the controller and the sensor. With the wires disconnected, measure the resistance from wire-to-wire with a multimeter. The meter should read greater than 10 Meg-ohms, open or OL depending on the meter. Short the interconnecting wires together at one end. Go to the other end and measure the resistance from wire-to-wire with a multimeter. The meter should read less than 10 ohms with 22 gauge or larger wire a distance of 250 feet (76m) or less. If either test fails, replace the wire.

Check power supply/controller voltage supply

Disconnect sensor and check power wires for proper voltage (see specifications on page 1).

Incorrect particulate output

Check all BAS controller software parameters.

Determine if the sensor is exposed to an external environment different from the room environment (conduit draft).

Output alternates between 50% and 100% of setting.

Check DIP switch S2. Only one of the three S2 switches can be set to "ON".