

Overview and Identification

The quality of the air that we breathe is essential to our health and knowing the air quality level is the first step to improving it. BAPI's VOC sensors provide that critical air quality information.

The CO₂ equivalent (CO₂e) units combine the benefits of VOC sensors and the common application of CO₂ sensors into one unit. It provides a VOC reading that correlates to a typical indoor CO₂ level of 0 to 2,000 ppm. This allows the sensor's output to be used for ASHRAE's CO₂-based VRP ventilation schedule.

Additional information on VOCs and using the CO₂e units in your ventilation strategy is available on our website and in the Air Quality section of our catalog.

The Duct Sensor samples duct air using an aspiration tube, while the Rough Service unit features a ventilated BAPI-Box and is ideal for areas such as outdoor air plenums, equipment rooms, green houses and warehouses. The VOC level is indicated as "Good, Fair or Poor" by three discrete green, yellow and red LED's on the front of the unit. If the output reaches 2,000 PPM, the red LED will begin to flash because it has hit its maximum output.

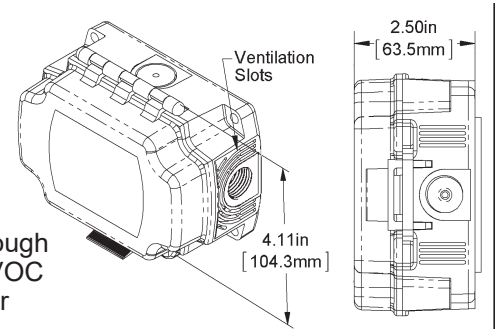

Fig. 1: Rough Service VOC Sensor

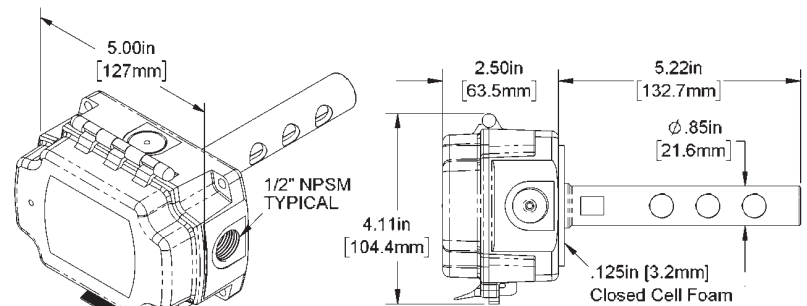

Fig. 2: Duct VOC Sensor

Mounting Template

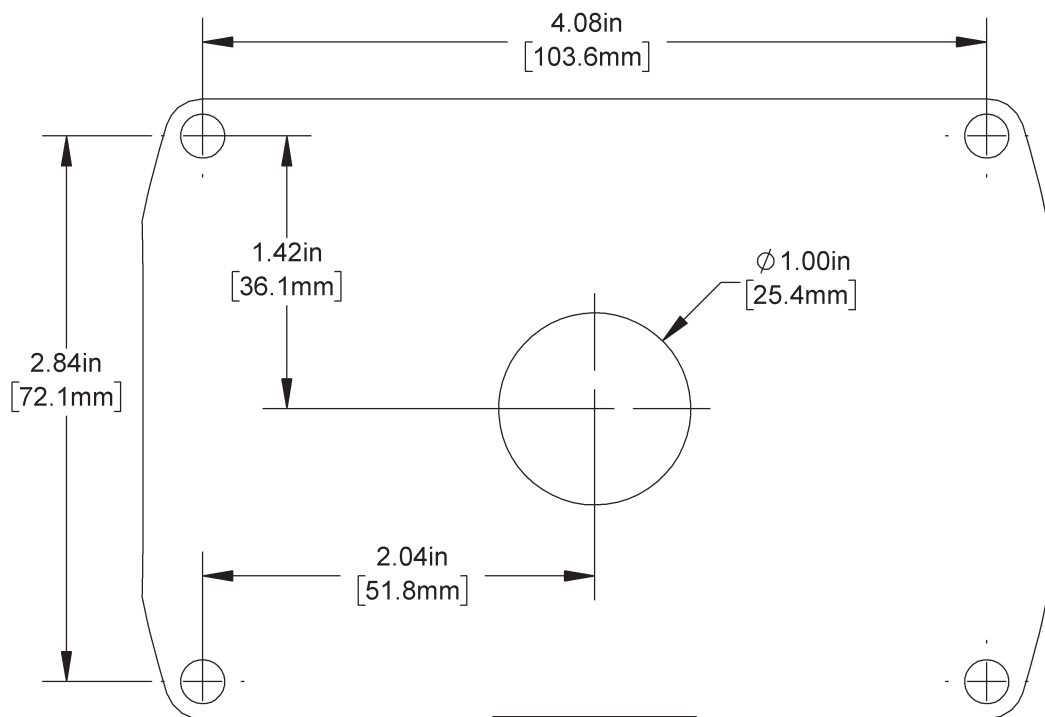
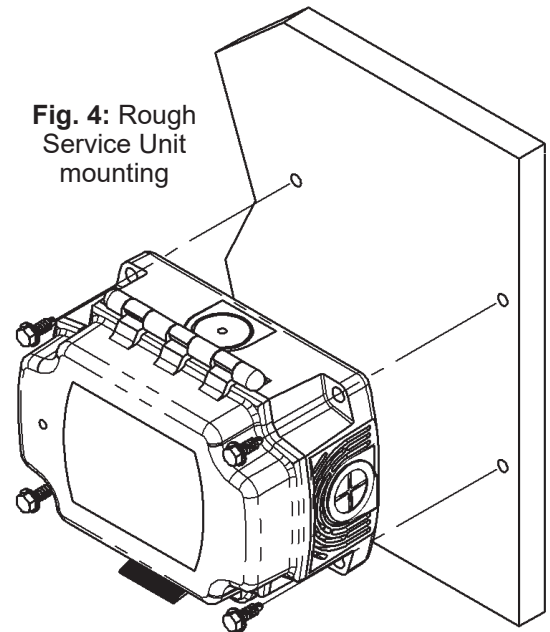

Fig. 3: Mounting Template, Actual Size

Rough Service Unit Mounting

1. Mount the unit on a solid, non-vibrating surface 3 to 5 feet above floor level or as specified by local building codes. Do not mount near supply or return diffusers.
2. Unit may be mounted in any orientation. If you are mounting inside a duct or mixing box, mount with the latch facing into the moving air.
3. Use the mounting template on the previous page (or the enclosure itself) to mark the pilot-hole locations. Use the 4 included #10 (M5) screws on the four mounting feet of the enclosure. A pilot-hole makes mounting easier.
4. Snug up the screws so that the foam backing is partially depressed but do not over-tighten or strip the screw threads. The foam is for insulation and vibration dampening.
5. Place the provided #6 screws into the holes on each side of the lid latch to make the cover tamper resistant.



Duct Unit Mounting

1. BAPI recommends placing the sensor in the middle of the duct wall, away from stratified air, to achieve the best reading. The unit should also be a minimum of 3 duct diameters from an elbow, damper or other duct restriction.
2. Drill a 1" (26mm) hole for the aspiration tube.
3. Position the box so that airflow is directly into the holes on one side of the aspiration tube. There are no upstream or downstream holes, the air direction is not important.
4. Use the mounting template on the previous page (or the enclosure itself) to mark the pilot-hole locations. Use the 4 included #10 (M5) screws on the four mounting feet of the enclosure. A pilot-hole makes mounting easier.
5. Snug up the screws so that the foam backing is partially depressed but do not over-tighten or strip the screw threads. The foam is for insulation and vibration dampening, and to prevent air leakage.
6. Place the provided #6 screws into the holes on each side of the lid latch to make the cover tamper resistant.

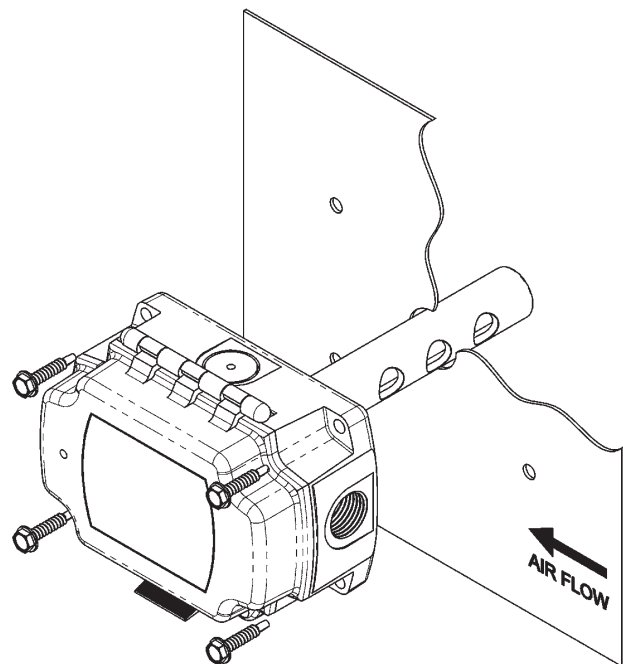

Termination

BAPI recommends using twisted pair of at least 22AWG for all wire connections. Larger gauge wire may be required for long runs. All wiring must comply with the National Electric Code (NEC) and local codes. Do NOT run this device's wiring in the same conduit as AC power wiring of NEC class 1, NEC class 2, NEC class 3 or with wiring used to supply highly inductive loads such as motors, contactors and relays. BAPI's tests show that fluctuating and inaccurate signal levels are possible when AC power wiring is present in the same conduit as the signal lines. If you are experiencing any of these difficulties, please contact your BAPI representative.



BAPI recommends wiring the product with power disconnected. Proper supply voltage, polarity and wiring connections are important to a successful installation. Not observing these recommendations may damage the product and void the warranty.

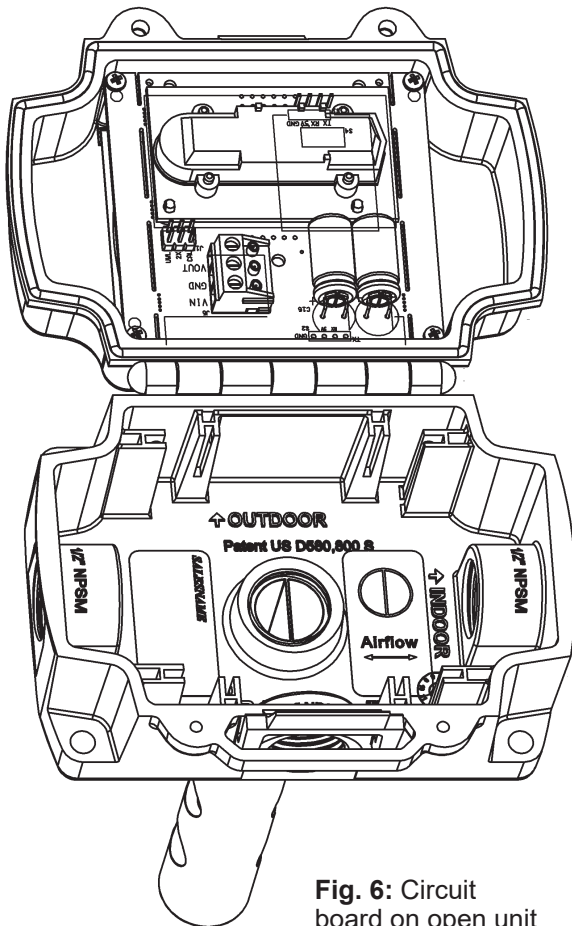

Fig. 6: Circuit board on open unit

Terminal	Description
VIN	Power, referenced to GND 12 to 24 VDC, 35 mA Max 18 to 24 VAC, 4 VA Max
GND	To controller Ground [GND or Common]
VOUT	Voltage Output, VOC Signal (0 to 2,000 ppm CO ₂ equivalent), referenced to GND

Voltage Output Jumper 2X

The VOC outputs may be field configured for 0 to 5 VDC or 0 to 10 VDC outputs at any time. Set the 2X jumper on J1 as shown in Figs 7 and 8.

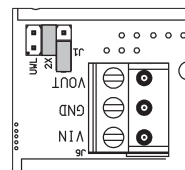

Fig. 7: J1 set for 0 to 10 VDC output

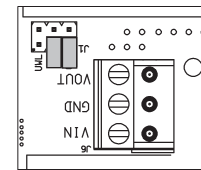

Fig. 8: J1 set for 0 to 5 VDC output

Keeping the Enclosure Air Tight After Termination

For the sensor to work correctly, the wiring entrance must remain air tight. If the VOC sensor is mounted to a hollow wall and wired through its back, or wired with conduit, it is possible that a draft of clean air may fill the enclosure through the wiring opening. This draft may prevent the unit from measuring ambient VOCs. BAPI recommends either a liquid-tight fitting or plugging the conduit at the enclosure.

- **Liquid-Tight Fitting** – BAPI's Liquid-Tight Fitting (BA/LTF) allows wire cables of 0.1 to 0.3 inch (2.5 to 7.6mm) outside diameter to enter the box. Tightening the collar onto the wire cable keeps the wiring entrance air tight.

- **Conduit** – Included with the VOC sensor is a foam plug to seal the ½ inch (13mm) EMT. Place the wires into the plug as shown in Fig. 9 and then insert the plug into the conduit sealing the conduit.

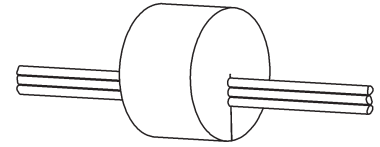

Fig. 9:
Wires Through Foam Plug

Sensor Start-Up

At each power up, the sensor enters a 15 minute start-up period. During this time, the sensor warms up, stabilizes to its environment, and then begins normal operation.

For units with LEDs. All 3 LEDs on the face of the sensor will flash for 25 seconds at start-up. Then the green LED will be solid and the red LED will flash for the next 8 minutes. For the last 6 minutes and 30 seconds, the sensor stabilizes to its environment and only the LED equivalent to the environment will be solid.

Do not set the building control system's VOC limit parameter until the VOC sensor has been installed for a week. The sensor uses the first few days after install to baseline and normalize its CO₂e output algorithm.

Optional Sensor Performance Verification and Commissioning

A simple bump test is performed to verify that the sensor responds to elevated VOC levels.

1. Ensure that the sensor has been powered on for at least 15 minutes.
2. Apply a stimulus gas to the sensor as described in Stimulus Preparation and Application.
3. That amount of alcohol vapor will normally exceed the sensor's max output. If so, the output voltage should read 5 or 10 volts depending on the jumper setting. The red LED should flash since the reading is greater than 2,000 ppm (CO₂e).
4. As the vapor dissipates, the output voltage will decrease and the LEDs will turn on and off as the ppm level changes.
5. It may take more than 10 minutes to return to normal VOC levels.

Stimulus Preparation and Application

Place 50ml of the Isopropyl Alcohol (70% minimum) into a 200ml bottle (2oz in an 8oz bottle) with a cover and allow it to reach room temperature.

1. Remove the cover from the alcohol bottle, place the tip of the syringe at least half-way into the bottle and withdraw a 60 ml sample of the alcohol vapor. (No liquid)
2. Place the end of the syringe under, or into the bottom ventilation slot of the VOC sensor's housing.
3. Empty the syringe into a ventilation slot or the partially opened cover of the BAPI-Box.

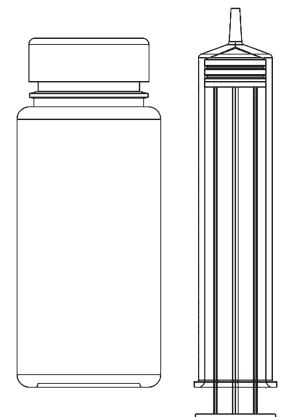

Fig. 10: Alcohol Bottle and Syringe included in the VOC Verification Kit (BA/VOC-KIT)



VOC (CO₂e) Duct and Rough Service Sensor

Installation & Operating Instructions

40699_ins_VOC_3LED_BB

rev. 05/27/21

Diagnostics

Possible Problems:

General Troubleshooting

Incorrect VOC Reading

Possible Solutions:

- Determine that the input is set up correctly in the controller and BAS software.
- Check wiring at the sensor and controller for proper connections. If there is corrosion on any terminations, clean off the corrosion, re-strip the interconnecting wire and reapply the connection. In extreme cases, replace the controller, interconnecting wire and/or sensor.
- Label the VOC sensor wire terminals at the sensor and controller ends. Disconnect the wires and measure the resistance from wire-to-wire with a multimeter. The meter should read greater than 10 Megohms, open or OL depending on the meter. Short the wires at one end and measure the resistance from wire-to-wire at the other end. The meter should read less than 10 ohms for 22 gauge or larger wire at a distance of 250 feet (76m) or less. If either test fails, replace the wire.
- Check the power supply and controller voltage supply.
- Disconnect sensor and check power wires for proper voltage (see power specs).
- Wait 15 minutes after a power interruption.
- Check all software parameters.
- Determine if the sensor is exposed to an external environment different from the room (conduit draft).

Specifications

Power: (Half-wave rectified)

12 to 24 VDC, 35 mA max
18 to 24 VAC, 4 VAmx

CO₂e Unit Detection Range:

0 to 2,000 ppm CO₂ equivalent

Sensing Element:

Micro-machined metal oxide

Start-Up Time:

15 minutes

Response Time:

<60 sec (after start-up time)

Selectable Output:

0 to 5 or 0 to 10 VDC > 10KΩ impedance

Wiring:

3 wires, 16 to 22 AWG

Cover LEDs for CO₂e Models

Good, Green < 1,000 PPM

Fair, Yellow = 1,000 to 1,500 PPM

Poor, Red > 1,500 PPM

Operating Environment:

32 to 122°F (0 to 50°C)

5 to 95%RH non-condensing

Enclosure Material:

UV-Resistant Polycarbonate, UL94, V-0

Agency:

CE EN 61326-1:2013 EMC, UL, RoHS

Specifications subject to change without notice.