

### Overview and Identification

- BAPI-Stat “Quantum” Enclosure Style
- Optional Setpoint, Override and Communication Jack
- Pressure Pickup Port available for units without Setpoint or Override
- Limited Lifetime Warranty

The BAPI-Stat “Quantum” room sensor without display features BAPI’s newest low-profile enclosure design. It is available with optional slider setpoint adjustment, occupant override and 3.5mm phone style communications jack.

It is also available with a Pressure Pickup Port for units without Setpoint or Override.

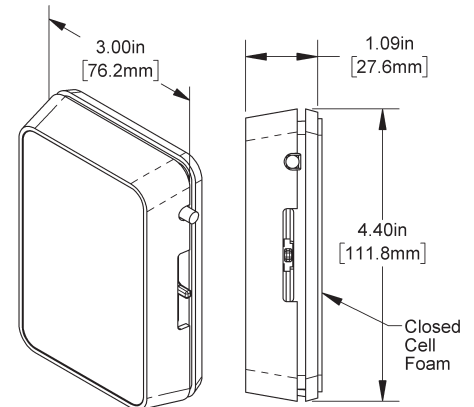
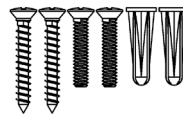

**Fig. 1:** BAPI-Stat “Quantum” Room Sensor without Display and included screw pack.

### Mounting

Mounting hardware is provided for both junction box (J-box) and drywall installation (J-Box installation shown below).

#### JUNCTION BOX

1. Pull the wire through the wall and out the junction box, leaving about six inches free. Pull the wire through the hole in the base plate.
2. Secure the base to the box using the #6-32 x 5/8 inch mounting screws provided.
3. Terminate the unit according to the guidelines in the **Termination** section.
4. Attach Cover by latching it to the top of the base, rotating the cover down and snapping it into place.
5. Secure the cover by backing out the lock-down screws using a 1/16” Allen wrench until they are flush with the bottom of the cover.

#### DRYWALL MOUNTING

1. Place the base plate against the wall where you want to mount the sensor. Mark the two mounting holes and the area where the wires will come through the wall.
2. Drill two 3/16” holes in the center of each marked mounting hole. Insert a drywall anchor into each hole.
3. Drill one 1/2” hole in the middle of the marked wiring area. Pull the wire through the wall and out of the 1/2” hole, leaving about six inches free.
4. Pull the wire through the hole in the base plate.
5. Secure the base to the drywall anchors using the #6 x 1 inch mounting screws provided.
6. Terminate the unit according to the guidelines in the **Termination** section.
7. Attach Cover by latching it to the top of the base, rotating the cover down and snapping it into place. Secure the cover by backing out the lock-down screws using a 1/16” Allen wrench until they are flush with the bottom of the cover.

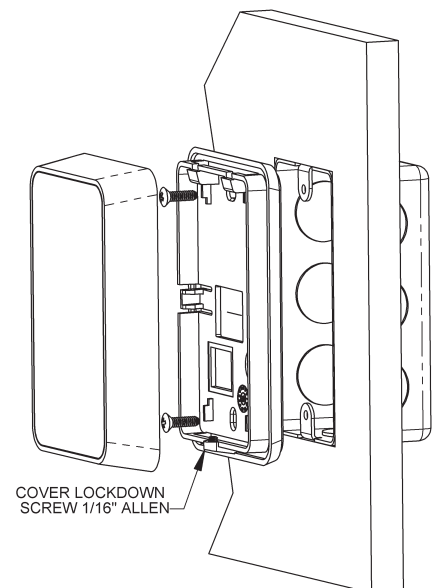

**Fig. 2:** BAPI-Stat “Quantum” J-Box Mounting

**NOTE:** In a wall-mount application, the mixing of room air and air from within the wall cavity can lead to erroneous readings, condensation, and premature failure of the sensor. To prevent this condition, plug the conduit hole with insulation in the junction box.

Specifications subject to change without notice.

### Wiring & Termination

BAPI recommends using twisted pair of at least 22AWG and sealant filled connectors for all wire connections. Larger gauge wire may be required for long runs. All wiring must comply with the National Electric Code (NEC) and local codes. Do NOT run this device's wiring in the same conduit as high or low voltage AC power wiring. BAPI's tests show that inaccurate signal levels are possible when AC power wiring is present in the same conduit as the sensor wires.



BAPI recommends wiring the product with power disconnected. Proper supply voltage, polarity, and wiring connections are important to a successful installation. Not observing these recommendations may damage the product and will void the warranty.

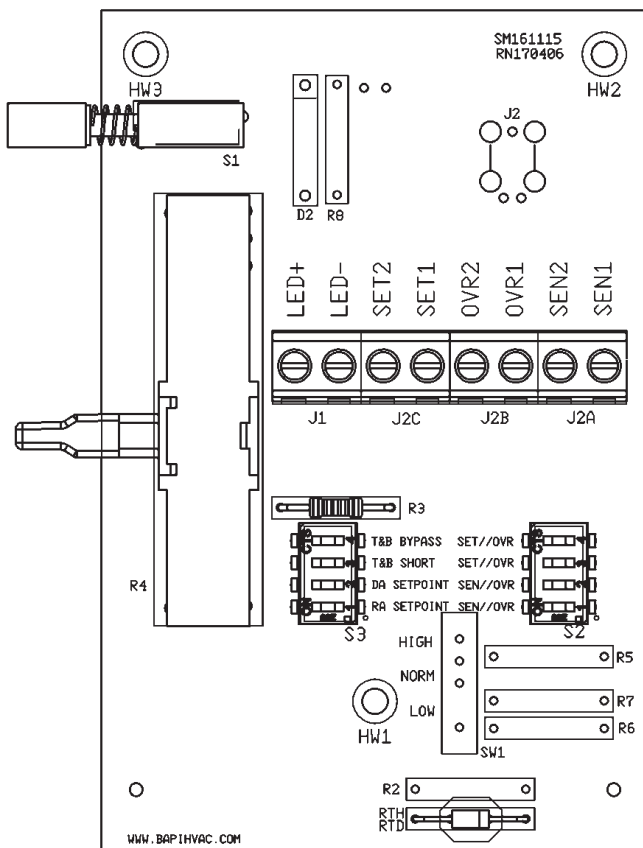

Fig. 3: Circuit board

### Common Wiring

- SET 2 .... Setpoint, **Resistance Output**, To analog input of controller [Common Ground]
- SET 1..... Setpoint, **Resistance Output**, To analog input of controller
- OVR2..... Override, **Normally OPEN**, To analog or digital input of controller [Common Ground]
- OVR1..... Override, **Normally OPEN**, To analog or digital input of controller
- SEN 2 .... Temperature, **Resistance Output**, To analog input of controller [Common Ground]
- SEN 1 .... Temperature, **Resistance Output**, To analog input of controller
- LED+ ..... Override Occupancy LED, V+ input from controller (LED is activated with 5VDC to 12VDC across LED+ and LED-)
- LED- ..... Override Occupancy LED, Neutral or GND input from controller (LED is activated with 5VDC to 12VDC across LED+ and LED-)

Note: If unit is configured for common ground, then SET2, OVR2 and SEN2 are connected together.

### Test & Balance Switch (SW1)



**High:** Will set the sensor value HIGH temperature



**Norm:** Thermistor/RTD will operate normally



**Low:** Will set the sensor value LOW temperature

Sensor Type	Low Temp (40° F) Resistance Value	High Temp (105° F) Resistance Value
1000Ω RTD	1.02KΩ (41.2°F)	1.15KΩ (101.5°F)
3000Ω Thermistor	7.87KΩ (39.5°F)	1.5KΩ (106.8°F)
10K-2 Thermistor	30.1KΩ (39.2°F)	4.75KΩ (105.8°F)
10K-3 Thermistor	26.7KΩ (35.9°F)	5.11KΩ (108.4°F)
10K-3(11K) Thermistor	7.32KΩ (43.7°F)	3.65KΩ (105.2°F)

Specifications subject to change without notice.

### Setpoint Dip Switch (S3) Settings - Direct Acting (DA) or Reverse Acting (RA)

Note: If unit does not have Test & Balance option, leave Position 4 ON

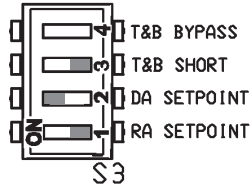

Direct Acting Setpoint

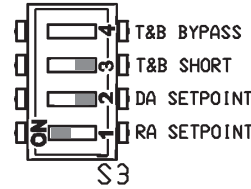

Reverse Acting Setpoint

### Override Dip Switch (S2) Settings

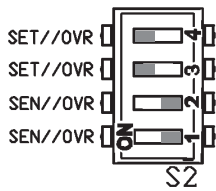

Override in Parallel with Setpoint: Differential Ground Units

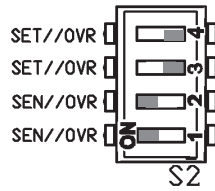

Override in Parallel with Sensor: Differential Ground Units

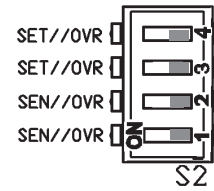

Override as a Separate Output or No Override: Differential Ground Units

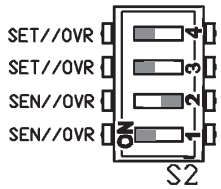

Override in Parallel with Setpoint: Common Ground Units

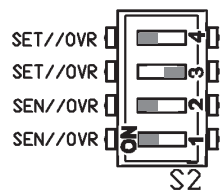

Override in Parallel with Sensor: Common Ground Units

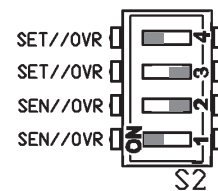

Override as a Separate Output or No Override: Common Ground Units

### Communication Jack Termination

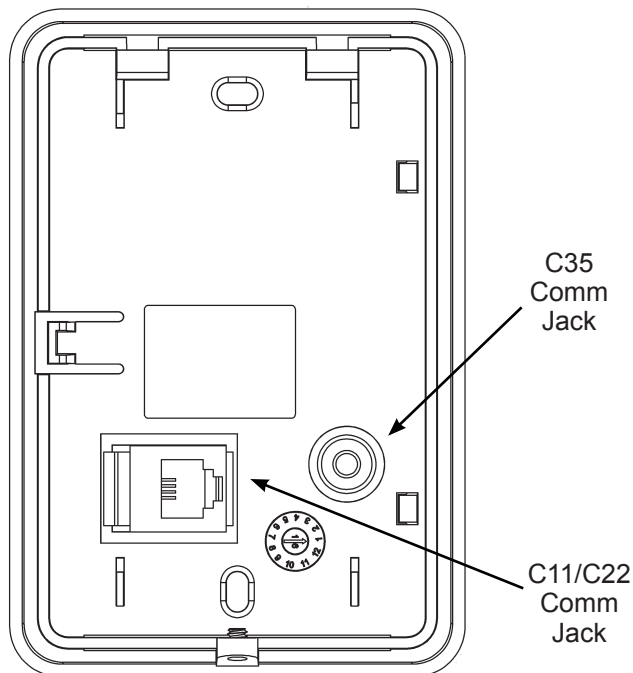

Fig. 4: Back Plate of the BAPI-Stat "Quantum"

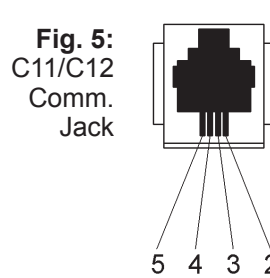

Fig. 5: C11/C12 Comm. Jack

#### C11/C12 Wiring

- Pin #1 Not Connected
- Pin #2 to Comm Jack pin 2
- Pin #3 to Comm Jack pin 3
- Pin #4 to Comm Jack pin 4
- Pin #5 to Comm Jack pin 5
- Pin #6 Not Connected

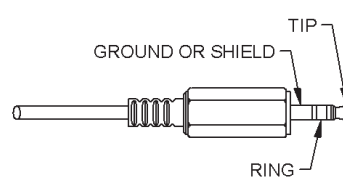

Fig. 6: C35 Comm. Jack (3.5mm plug shown for clarity)

C35 Wiring	
	Terminal #
Ground	Net A
Tip	Net B
Ring	Not Connected

Specifications subject to change without notice.



38427\_ins\_uniq

# BAPI-Stat “Quantum” Room Temperature Sensor Without Display

Installation & Operations

rev. 05/25/18

## Troubleshooting

### Possible Problems:

Controller reports temperature that is higher or lower than actual temperature

### Possible Solutions:

- Confirm the input is set up correctly in the front end software
- Check wiring for proper termination
- Determine if the sensor is exposed to an external source different from room environment such as conduit draft. If the sensor is exposed to conduit draft, fill the box with fiberglass or polyester fill or plug the conduit.
- If the unit has a test and balance switch, make sure it is in the center position.
- Compare the sensor’s resistive output to the actual temperature in the room. Measure the temperature at the sensor’s location using an accurate standard. Disconnect the temperature sensor wires (SEN1 to SEN2) and measure the actual resistance across pins with an ohmmeter. Compare the sensor’s resistance to the appropriate temperature sensor table on the BAPI website. If the measured resistance varies by more than 5% from the temperature table, call BAPI technical support. To view the temperature table, go to the BAPI website ([www.bapihvac.com](http://www.bapihvac.com)), click on “Resource Library” and “Sensor Specs”, then click on the type of sensor you have.

Setpoint is not working correctly

- Check for proper wire termination at the SET1 and SET2 pins
- Verify that the resistive output across the SET1 and SET2 pins changes as the setpoint slider is moved up and down. If the measured resistance does not change, call BAPI technical support.
- Verify that Setpoint Dip Switch S3 is set up for Reverse Acting (RA) or Direct Acting (DA) as specified by your BAS.

Override is not working correctly

- Check for proper wire termination at the OVR1 and OVR2 pins
- Verify that the output across the OVR1 and OVR2 pins is less than 50 ohms when the override button is pressed. If the measured resistance is not less than 50 ohms, call BAPI technical support.
- Verify that Override Dip Switch (S2) is set up as specified by your BAS.

Specifications subject to change without notice.