

Overview and Identification

Strap Sensors are made for direct pipe mounting and temperature measurement of water pipe applications.

The Clamp-On units are for mounting before any insulation is on the pipe and the Spring-Loaded units are for mounting to pipes with up to 2" of insulation using a unique spring sensor extension. Strap units are available in multiple thermistor or RTD types as shown in the specifications.

The BAPI-Box Crossover enclosure has a hinged cover for easy termination and comes with an IP10 rating (or IP44 rating with a pierceable knockout plug installed in the open port).

This instruction sheet is specific to the units with the BAPI-Box Crossover Enclosure. For other enclosures, please refer to instruction sheet "20911_ins_Strap_On_Passive.pdf" which is available on the BAPI website or by contacting BAPI.

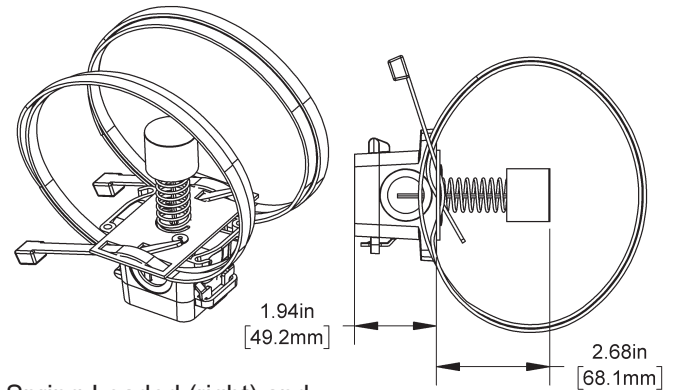
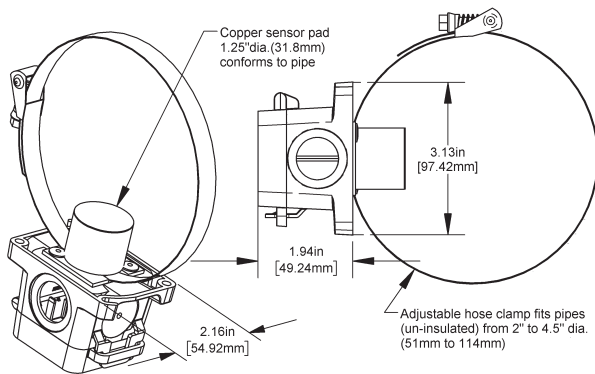

Fig. 1: Spring-Loaded (right) and Clamp-On Strap Sensors in a BAPI-Box Crossover Enclosure

Mounting of Clamp-On Strap Units

This sensor technique is for reading the fluid temperature in a pipe by reading the temperature of the pipe. Properly installed strap sensors with insulation around the local strap-on sight will offer a very accurate temperature of the water inside the pipe to within .5 °F or better of the inside pipe water temperature.

1. Fig 2 shows a typical installation for pipes from 2" to 4.5". Stripping away insulation is OK.
2. Larger pipes can be accommodated by adding another, customer supplied, stainless steel hose clamp extending the possible pipe diameter.
3. If there is insulation, clean away a section of the pipe insulation a minimum of 2" all around the pipe. The copper sensor pad and SS strap must be in direct contact with the metal or plastic pipe. Nothing should be between the copper plate sensor and the bare pipe.
4. Tighten the strap-so that the sensor does not rotate around the pipe and so that the foam is compressed not more than 50% allowing the copper sensor plate to form (bend) to the pipe curvature for maximum temperature conduction. BAPI recommends pre-forming the copper plate by bending it around the pipe with your fingers.
5. After the sensor is securely mounted, add insulation a minimum of 1" thick and a minimum of 4 pipe diameters on each side of the copper sensor pad. (Example: A 2" pipe should have 8" of insulation on each side of the sensor). Only cover the sensor box to the top of the door hinge.

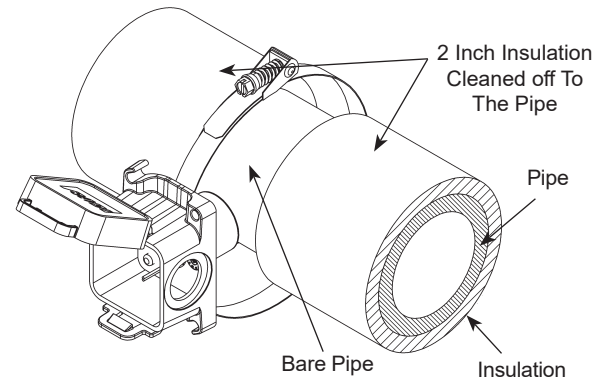

Fig 2: Clamp-On Strap with BAPI-Box Crossover Enclosure installation

Specifications subject to change without notice.

Mounting of Spring-Loaded Strap Units

This sensor technique is for reading the fluid temperature in a pipe by reading the temperature of the pipe. Properly installed strap sensors with insulation around the local strap-on sight will offer a very accurate temperature of the water inside the pipe to within .5 °F or better of the inside pipe water temperature.

1. Fig 3 shows a typical installation for insulated pipes from 5" to 14" and insulation thickness from 0.5" to 2.5".
2. Larger pipes can be accommodated by adding another customer-supplied cable tie, extending the possible pipe diameter.
3. Make a 1.5 inch diameter hole in the insulation where the sensor is to be placed and clean the pipe from debris. Extend the spring so the copper sensor pad is in direct contact with the metal or plastic pipe. No debris should be between the copper plate sensor and the bare pipe. The spring can retract to a minimum insulation thickness of ~.5" compressed to ~2.5" extended.
4. Position the box and sensor over the hole.
5. Tighten the cable ties so that the sensor spring is compressed no more than 50% allowing the copper sensor plate to form (bend) to the pipe curvature for maximum temperature conduction. BAPI recommends pre-forming the copper plate by bending it around the pipe with your fingers. Extend the spring further by turning it clockwise if the copper sensor plate contact is questionable. The copper sensor plate must be in direct contact with the pipe.
6. After the strap on sensor is securely mounted, add insulation back in (backfill) around the spring extension, using the removed insulation, so that no heat or cold from the pipe can escape.
7. If more insulation is desired, only cover the sensor box to the top of the door hinge.

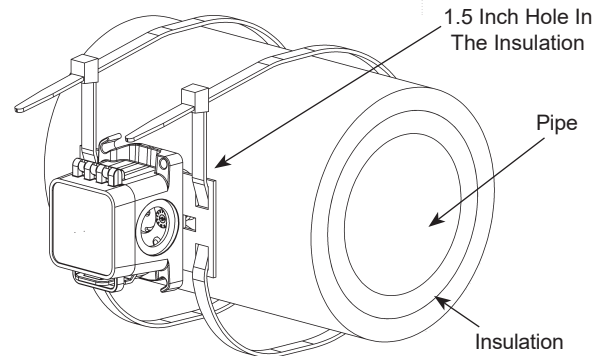

Fig 3: Spring-Loaded Strap with BAPI-Box Crossover Enclosure installation

Wiring & Termination

BAPI recommends using twisted pair of at least 22AWG and sealant filled connectors for all wire connections. Larger gauge wire may be required for long runs. All wiring must comply with the National Electric Code (NEC) and local codes. Do NOT run this device's wiring in the same conduit as high or low voltage AC power wiring. BAPI's tests show that inaccurate signal levels are possible when AC power wiring is present in the same conduit as the sensor wires.

THERMISTOR AND RTD TERMINATION

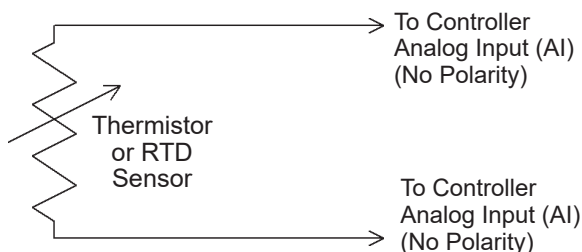

Fig. 4: 2-Wire Termination for Thermistor or RTDs

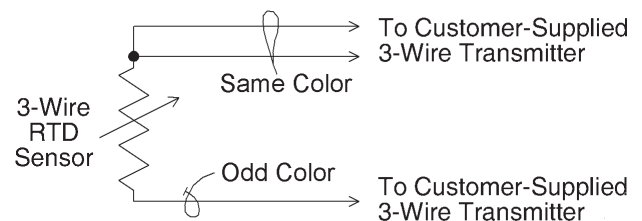

Fig. 5: 3-Wire Termination for RTDs

Specifications subject to change without notice.

Wiring & Termination continued...

UNITS WITH A TERMINAL STRIP AND TEST AND BALANCE SWITCH

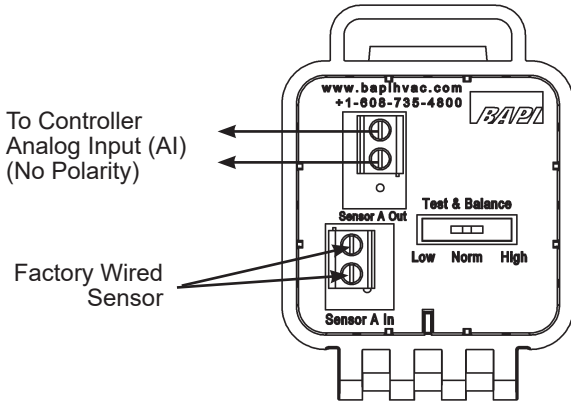

Fig. 6: Terminal Strip (-TS) or Test and Balance (TB) Option for 2 Wire Sensors

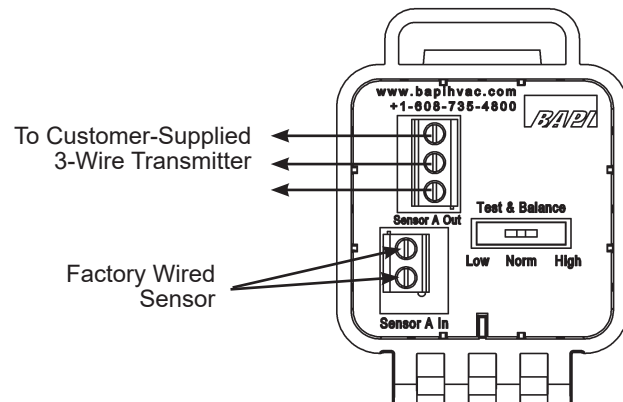

Fig. 7: Terminal Strip (-TS) or Test and Balance (TB) Option for 3 Wire Sensors

TEST AND BALANCE SWITCH:

For units with a Test and Balance Switch, the Norm position allows the real sensor at be monitored at “Sensor A Out”. The High position forces the “Sensor A Out” to a very hot reading and the Low position forces “Sensor A Out” to a very cold reading (see Table below).

Sensor Type	Low Temp (40° F) Resistance Value	High Temp (105° F) Resistance Value
1000Ω RTD	1.02KΩ (41.20°F)	1.15KΩ (101.5°F)
3000Ω Thermistor	7.87KΩ (39.8°F)	1.5KΩ (106.8°F)
10K-2 Thermistor	30.1KΩ (34.9°F)	4.75Ω (109.1°F)
10K-3 Thermistor	26.7KΩ (35.9°F)	5.11KΩ (108.4°F)
10K-3(11K) Thermistor	7.32KΩ (43.7°F)	3.65Ω (105.2°F)

Diagnosics

Possible Problems:

Controller reports higher or lower than actual temperature

Possible Solutions:

- Confirm the input is set up correctly in the front end software
- Check wiring for proper termination & continuity. (shorted or open)
- If the unit has a Test and Balance switch, make sure that the switch is in the center “Norm” position.
- Measure the physical temperature at the temperature sensor’s location using an accurate temperature standard. Disconnect the temperature sensor wires and measure the temperature sensor’s resistance across the sensor output pins with an ohmmeter. Compare the temperature sensor’s resistance to the appropriate temperature sensor table on the BAPI website. If the measured resistance is different from the temperature table by more than 5% call BAPI technical support. Find BAPI’s website at www.bapihvac.com; click on “Resource Library” and “Sensor Specs” then click on the type of sensor you have.

Specifications subject to change without notice.



String-Loaded Strap and Clamp-On Strap Temperature Sensors in a BAPI-Box Crossover Enclosure

Installation & Operations

37714_ins_strapclamp_passive_bbx

rev. 06/24/21

Specifications

SENSOR SPECS

Sensor: Passive

Thermistor NTC, 2 wire
RTD PTC, 2 or 3 wire

Thermistor: Thermal resistor

Temp. Output Resistance
Accuracy (Std) $\pm 0.36^{\circ}\text{F}$, ($\pm 0.2^{\circ}\text{C}$)
Accuracy (High) $\pm 0.18^{\circ}\text{F}$, ($\pm 0.1^{\circ}\text{C}$), [XP] option
Stability $< 0.036^{\circ}\text{F}/\text{Year}$, ($< 0.02^{\circ}\text{C}/\text{Year}$)
Heat Dissipation $2.7 \text{ mW}/^{\circ}\text{C}$
Temp. Drift $< 0.02^{\circ}\text{C}$ per year
Probe Range -40° to 221°F (-40° to 105°C)

RTD: Resistance Temperature Device

Platinum (Pt) 100Ω or $1\text{K}\Omega$ @ 0°C , 385 curve,
Platinum (Pt) $1\text{K}\Omega$ @ 0°C , 375 curve
Pt Accuracy (Std) ... 0.12% @Ref, or $\pm 0.55^{\circ}\text{F}$, ($\pm 0.3^{\circ}\text{C}$)
Pt Accuracy (High) . 0.06% @Ref, or $\pm 0.277^{\circ}\text{F}$
($\pm 0.15^{\circ}\text{C}$), [A]option

Pt Stability $\pm 0.25^{\circ}\text{F}$, ($\pm 0.14^{\circ}\text{C}$)
Pt Self Heating $0.4^{\circ}\text{C}/\text{mW}$ @ 0°C
Pt Probe Range -40° to 221°F , (-40 to 105°C)
Nickel (Ni) 1000Ω @ 70°F , JCI curve
Ni Probe range -40° to 221°F (-40 to 105°C)

Sensitivity: Approximate @ 32°F (0°C)

Thermistor Non-linear
See bapihvac.com "Sensor Specs"

 $1\text{K}\Omega$ RTD (Pt) $3.85\Omega/^{\circ}\text{C}$
 100Ω RTD $0.385\Omega/^{\circ}\text{C}$
Nickel (Ni) $2.95\Omega/^{\circ}\text{F}$ for the JCI RTD

ENCLOSURE AND WIRING SPECS

BAPI-Box Crossover Enclosure Ratings:

IP10, NEMA 1
IP44 with knockout plug installed in the open port

BAPI-Box Crossover Enclosure Material:

UV-resistant polycarbonate & Nylon, UL94V-0

Environmental Operating Range:

-40 to 185°F (-40 to 85°C)
 0 to 100% RH, Non-condensing

Lead Wire:

22AWG stranded

Wire Insulation:

Etched Teflon, Plenum rated

Probe:

Copper sensor plate, 24 AWG, 1.25" diameter

Mounting

Clamp-On Unit: 1/2" SS worm gear hose clamp
Spring-Loaded Unit: 48" Nylon cable tie, 1/2" wide

Agency:

RoHS
PT= DIN43760, IEC Pub 751-1983,
JIS C1604-1989

Specifications subject to change without notice.