

Identification and Overview

The BAPI Duct and Rough Service Refrigerant Leak Detectors sense a wide range of refrigerants. The sensor is temperature compensated for improved detection of leaks and spills. The output voltage increases as the concentration of the refrigerant increases in the space.

These units are not intended for critical ppm measurements nor life safety applications.

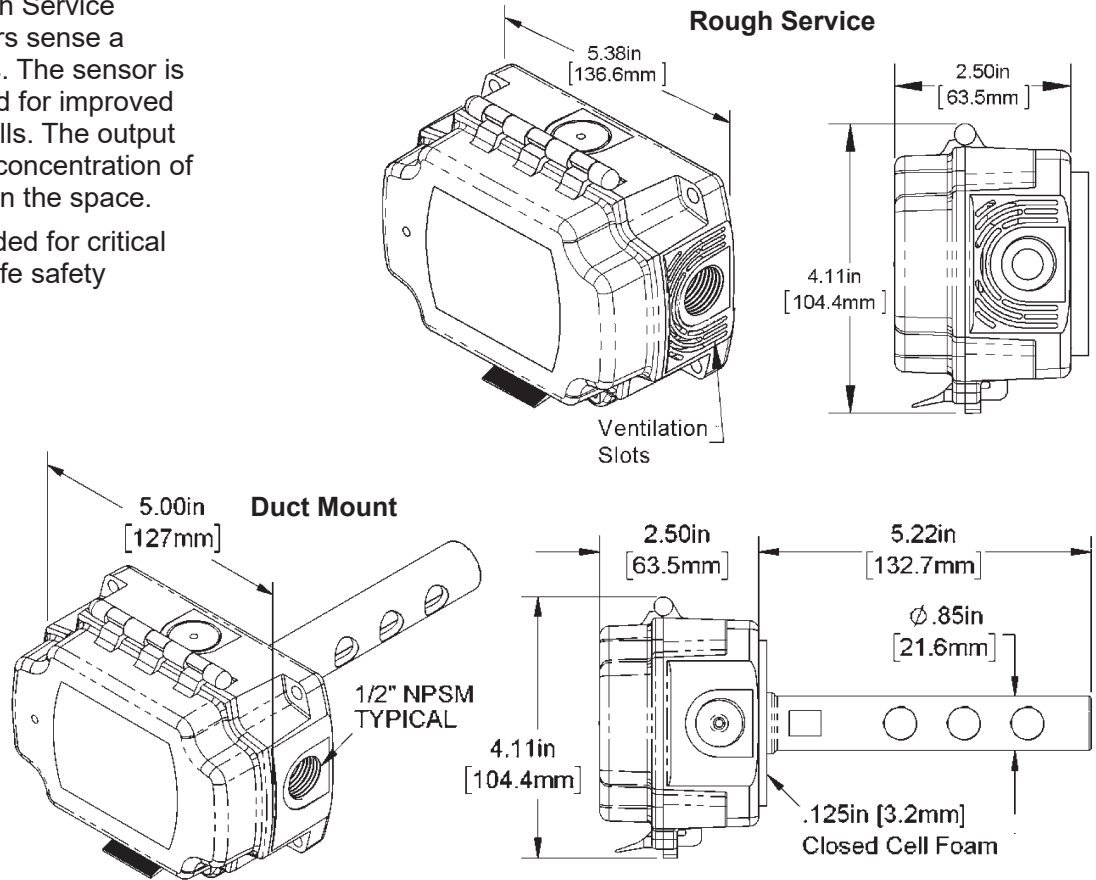

Fig. 1: BAPI Refrigerant Leak Detectors

Rough Service Unit Mounting

The mounting location must allow air to flow freely through the enclosure. The refrigerants this unit will detect are heavier than air and will settle in the lowest level in the space. Generally, the unit should be mounted 18" (450mm) above the floor. Make sure that there is an unobstructed path for a minimum of 12" (300mm) above and below the unit.

As a general rule, a single detector will have a coverage area of approximately a 50' (15m) radius.

1. Mount the unit horizontally as shown in Fig 2 on a solid, non-vibrating surface.
2. Hold the unit against the mounting surface to mark the mounting holes and drill for #10 screws (1/8" or 3mm drill).
3. Screw the unit to the mounting surface.

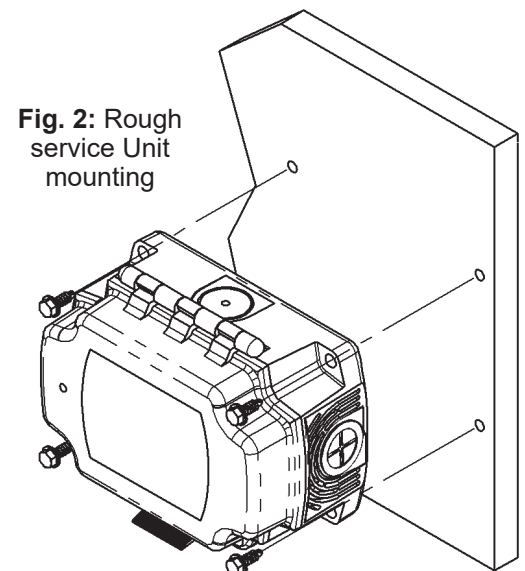

Duct Unit Mounting

1. BAPI recommends placing the sensor in the middle of the duct wall, away from stratified air, to achieve the best reading. The unit should also be a minimum of 3 duct diameters from an elbow, damper or other duct restriction.
2. Drill a 1" (26mm) hole for the aspiration tube.
3. Position the box so that airflow is directly into the holes on one side of the aspiration tube. There are no upstream or downstream holes, the air direction is not important.
4. Place the aspiration tube in the hole and hold the unit against the mounting surface to mark the mounting holes. Use the 4 included #10 (M5) screws on the four mounting feet of the enclosure. A pilot-hole makes mounting easier.
5. Snug up the screws so that the foam backing is partially depressed but do not over-tighten or strip the screw threads. The foam is for insulation and vibration dampening, and to prevent air leakage.
6. Place the provided #6 screws into the holes on each side of the lid latch to make the cover tamper resistant.

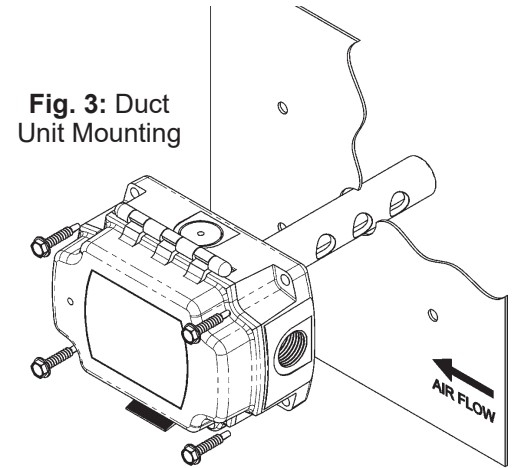

Termination

BAPI recommends using twisted pair wire of at least 22AWG for all wire connections. Larger gauge wire may be required for long runs. All wiring must comply with the National Electric Code (NEC) and local codes.

Do NOT run this device's wiring in the same conduit as AC power wiring of NEC class 1, NEC class 2, NEC class 3 or with wiring used to supply highly inductive loads such as motors, contactors and relays. BAPI's tests show that fluctuating and inaccurate signal levels are possible when AC power wiring is present in the same conduit as the signal lines. If you are experiencing any of these difficulties, please contact your BAPI representative.



BAPI recommends wiring the product with power disconnected. Proper supply voltage, polarity and wiring connections are important to a successful installation. Not observing these recommendations may damage the product and void the warranty.

Any port may be used for wire entry. If the back port is used, remove the sensor board prior to drilling the hole to prevent damaging the board.

Terminal and Description

Vin

Power, Referenced to GD, 9 to 40 VDC, 120 mA max or 19 to 32 VAC, 5 VA

GD

To Controller Ground [GND or Common]

Vo

Voltage Output, Referenced to GD, 4.8 VDC max

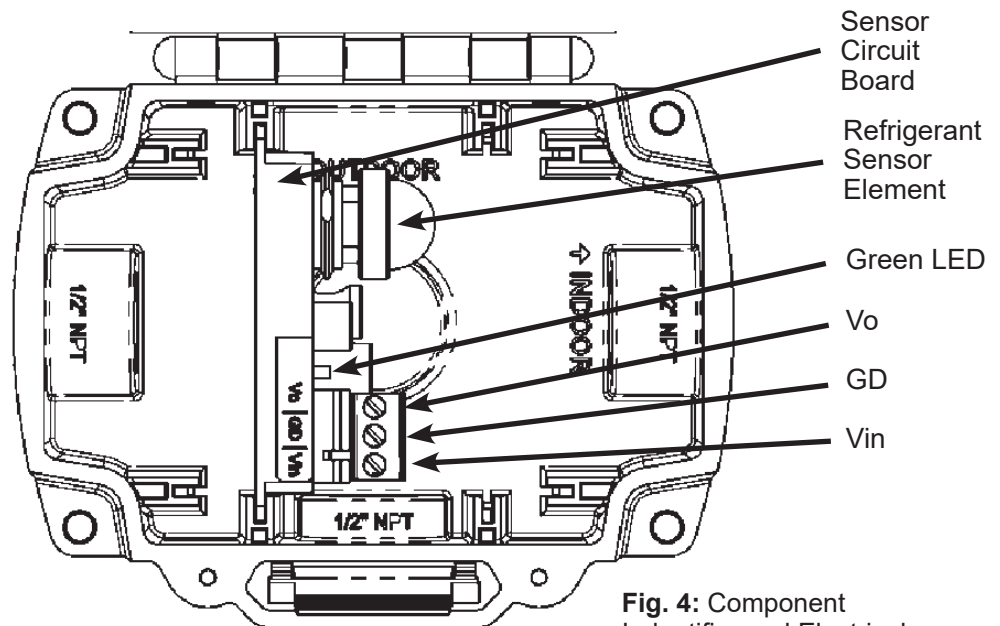

Fig. 4: Component Identifier and Electrical Connections

Note: Lightly tug on each wire after tightening to verify proper termination.

Keeping the Enclosure Air Tight After Termination

For the detector to work correctly, the wiring entrance must remain air tight. If the detector is mounted to a hollow wall and wired through its back, or wired with conduit, it is possible that a draft of clean air may fill the enclosure through the wiring opening. This draft may prevent the unit from measuring the ambient refrigerant. BAPI recommends either a liquid-tight fitting or plugging the conduit at the enclosure.

- **Liquid-Tight Fitting** – BAPI's Liquid-Tight Fitting (BA/LTF) allows wire cables of 0.1 to 0.3 inch (2.5 to 7.6mm) outside diameter to enter the box. Tightening the collar onto the wire cable keeps the wiring entrance air tight.
- **Conduit** – Included with the detector is a foam plug to seal the ½ inch (13mm) EMT. Place the wires into the plug as shown in Fig 5 and then insert the plug into the conduit sealing the conduit.

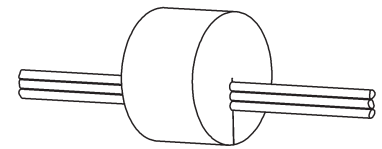

Fig. 5:
Wires Through Foam Plug

Operation

The BAPI Refrigerant Leak Detector has a sensing element that changes its electrical resistance with changes in refrigerant concentrations. As the concentration increases, so does the output voltage of the unit. The sensing element has a different sensitivity to each refrigerant and therefore the rate of increase of the output voltage is different for each refrigerant.

Allow up to 5 minutes after power-up for the output voltage to settle to the ambient conditions. Extended power outages may cause the output voltage to initially spike during those first 5 minutes after power is returned. The typical output in a clean air environment is between 0.1V to 0.3V. Therefore, BAPI recommends using 0.5V as the minimum detection voltage to minimize false alarms.

Any output voltage offsets must be applied at the controller.

The solid green LED indicates that the unit is powered.

The temperature sensor is for internal temperature compensation only.

Sensor Element Replacement

BAPI recommends replacing the sensor element every two years. Exposure to multiple events of high refrigerant concentrations or being exposed to refrigerants for long periods of time will shorten the life of the sensor element. If this occurs, BAPI recommends that you consider replacing the sensor element at that time.

1. Disconnect power from the unit and remove the sensor board from the enclosure.
2. Remove the old sensor element with your fingers by pulling the element out of its socket. Gently wiggle the element while pulling.
3. Install the new element by plugging it into the socket. The element is not polarity sensitive. Fully insert the element. The base of the element should be flush with the socket.
4. Reinstall the sensor board being careful not to pinch the temperature sensor wires.
5. Reconnect the unit to power.
6. Allow 5 minutes after power-up for the output voltage to settle to the ambient conditions. If the element has been in extended storage, additional time may be required.

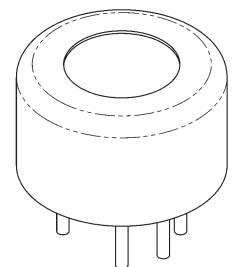

Fig. 6: Refrigerant
Sensor Element



Refrigerant Leak Detector

Installation & Operating Instructions

23983_ins_refrigerant

rev. 05/19/23

Diagnostics

POSSIBLE PROBLEMS:

Green LED is not on
No output voltage

POSSIBLE SOLUTIONS:

Check for correct power and wiring connections.
Sensing element is either unplugged from its socket or it is not operational.

Specifications

Power:

9 to 40 VDC at 120 mA max
19 to 32 VAC at 5 VA

Output Impedance: 680 Ohms

Output Voltage: 0 to 4.8 VDC

Ambient Temp: 32 to 140°F (0 to 60°C)

Sensor Element Life: 2 Years Typical

Warranty: 2 Years

Note: For a more complete list of detectable refrigerants, go to Resources on BAPI's website and view the Application Note "Refrigerants detected by the BAPI Refrigerant Leak Detector".

Refrigerants Detected by the Sensor		
Single Compound	Blends	
R-22 (A1)	R-404a (A1)	R-452a (A1)
R-32 (A2L)	R-407c (A1)	R-452b (A2L)
R-125 (A1)	R-407f (A1)	R-454a (A2L)
R-134a (A1)	R-410a (A1)	R-454b (A2L)
R-1234yf (A2L)	R-424a (A1)	R-454c (A2L)
R-1234ze (A2L)	R-434a (A1)	R-455a (A2L)
	R-447a (A2L)	R-466a (A1)
	R-448a (A1)	R-507 (A1)
	R-449a (A1)	R-513a (A1)
	R-450a (A1)	

Specifications subject to change without notice.