

Duct Static Pressure Probe Assembly

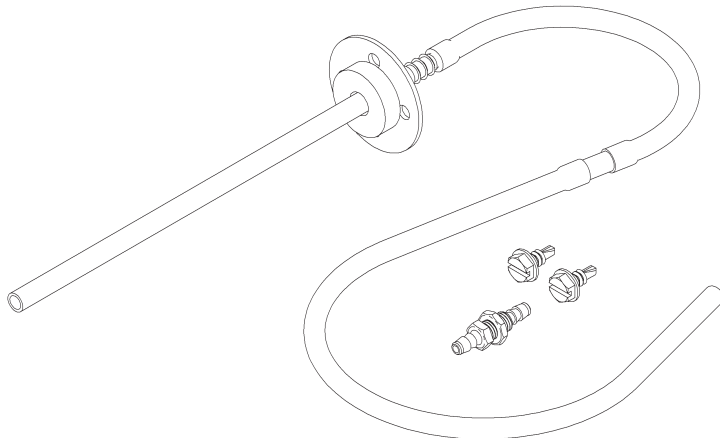

The duct static pressure probe assembly consists of a static pressure probe, a six inch piece of silicon rubber tubing, a twelve inch piece of silicon rubber tubing, two self drilling sheet metal screws and a pressure spike reducer.

Fig. 1: BAPI ZPS-ACC07

Mounting the Duct Static Pressure Probe, Hoses and Damper

Positioning the duct static pressure probe assembly to get the best results requires a little planning. Ideally the probe should be located 1/2 the distance from the fan to the end of the longest duct run. The probe should be a minimum of five duct diameters from any vanes, straighteners, reducers or bends. The probe may be placed within 1/2 duct diameter of a filter as long as the filter is five duct diameters from any other restriction.

Drill a 1/4 inch hole in the duct for the probe. Insert the 6 inch long section of the probe into the duct work and rotate so the air flow arrow is pointing in the same direction as the air flow in the duct. Using the two self drilling screws provided secure the probe to the duct. For round duct pick the two holes in the probe mounting flange that touch the duct surface. Position the probe so that it is at a right angle to the duct surface or at right angles to a line tangent to the duct surface for round duct. Being off by +/- 5 degrees angle is acceptable.

Long runs of tubing will damp out quick pressure fluctuations. Where the ZPS unit must be located close to the static pressure tube BAPI provides a pressure spike reducer. The pressure spike reducer provides a slight restriction in the tubing. The volume of tubing after the pressure spike reducer determines the time constant, the longer the tubing the greater the pressure spike reduction.

Place the 6" tube towards the pressure source. Connect the 12" tube to your ZPS pressure transmitter. If you do not get the dampening that you desire, increase the tubing length from the blue plastic snubber to the pressure sensor.

Condensation running down the interior of the tubing will damage the sensor. Forming a drip loop in the tubing just before it enters the ZPS transmitter is good practice, see Fig 4. The distance from the bottom of the loop to the ZPS's pressure port should be one to two inches (2.5 to 5 cm) greater than the highest air pressure, including error conditions, in the duct system.

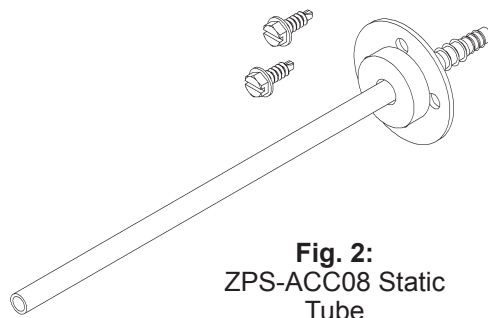

Fig. 2:
ZPS-ACC08 Static
Tube

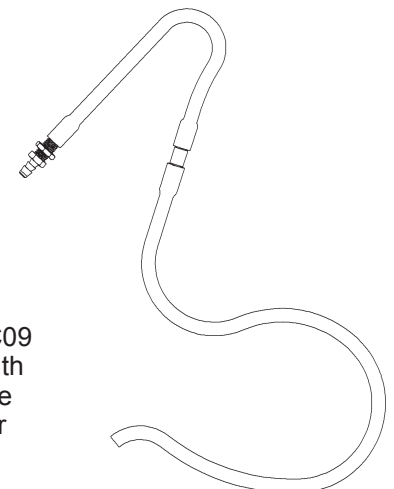

Fig. 3:
ZPS-ACC09
Hoses with
Pressure
Damper

Mounting Wall & Ceiling Pressure Pickup Ports

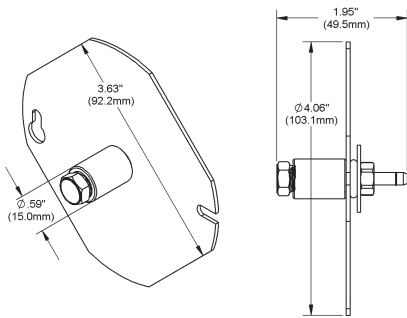

Fig. 6: Ceiling Mount Cover (ZPS-ACC05)

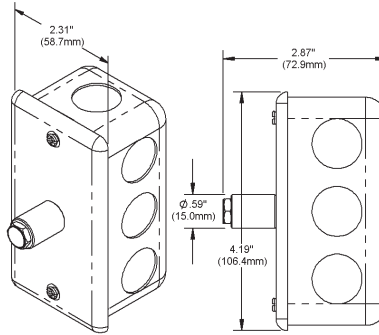

Fig. 7: Ceiling Mount Cover & J-Box (ZPS-ACC06)

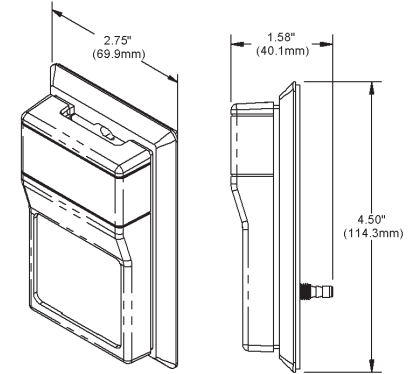

Fig. 8: Delta Style Enclosure (ZPS-ACC03)

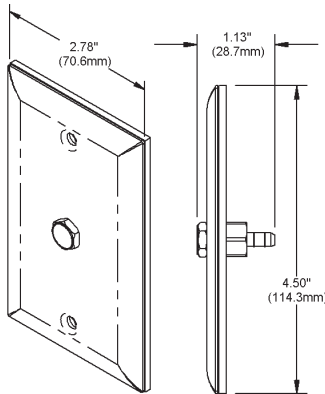

Fig. 9: Wall Plate (ZPS-ACC01)

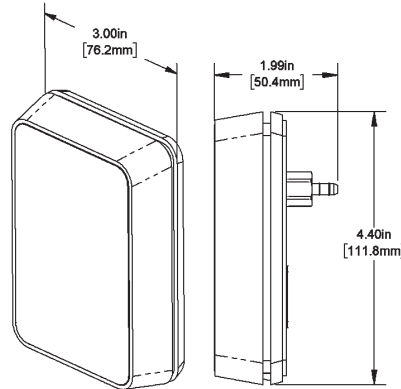

Fig. 10: BAPI-Stat "Quantum" (ZPS-ACC04) with standard mounting base

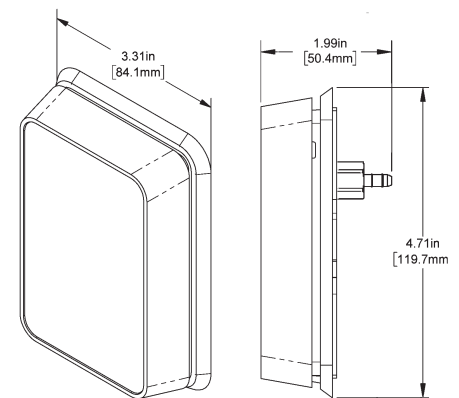

Fig. 11: BAPI-Stat "Quantum" (ZPS-ACC04-60) with 60mm mounting base to fit European wall boxes and junction boxes with 60mm mounting centers

Mount the static pressure pickup port in an area that is representative of the zone near the center of the zone. Do not mount in a closet or other enclosed space, or in areas that are prone to drafts.

It is best to mount the wall pickup port using an electrical box. A simple hole in the wallboard may be used, but be sure that the foam gasket on the back of the pickup seals tightly against the wall. Attach tubing to the barbed fitting on the back of the pickup port and run the tubing to the pressure sensor, forming a drip loop in the tubing just before connecting to the pressure sensor.

The ceiling pickups are sized to fit through a standard 3/4-inch thick acoustic ceiling tile. Cut a 5/8 inch hole in the tile. Place the static pressure sensor on top of the tile with the filter into the hole. The filter should stick out slightly below the tile's room surface. Attach tubing to the barbed fitting on the back of pickup port and run the tubing to the pressure sensor, forming a drip loop in the tubing just before connecting the tubing to the pressure sensor.

Typical Applications - Wall & Ceiling Pressure Pickup Ports

Fig. 12: Measuring static pressure differences between two rooms using two BAPI ZPS-ACC01 stainless steel wall plates and a BAPI ZPS Pressure Transmitter.

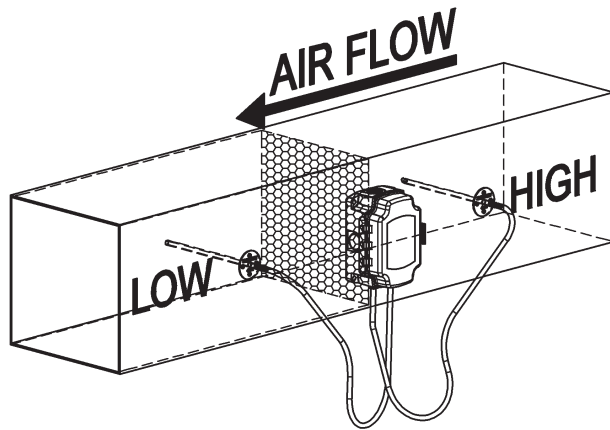
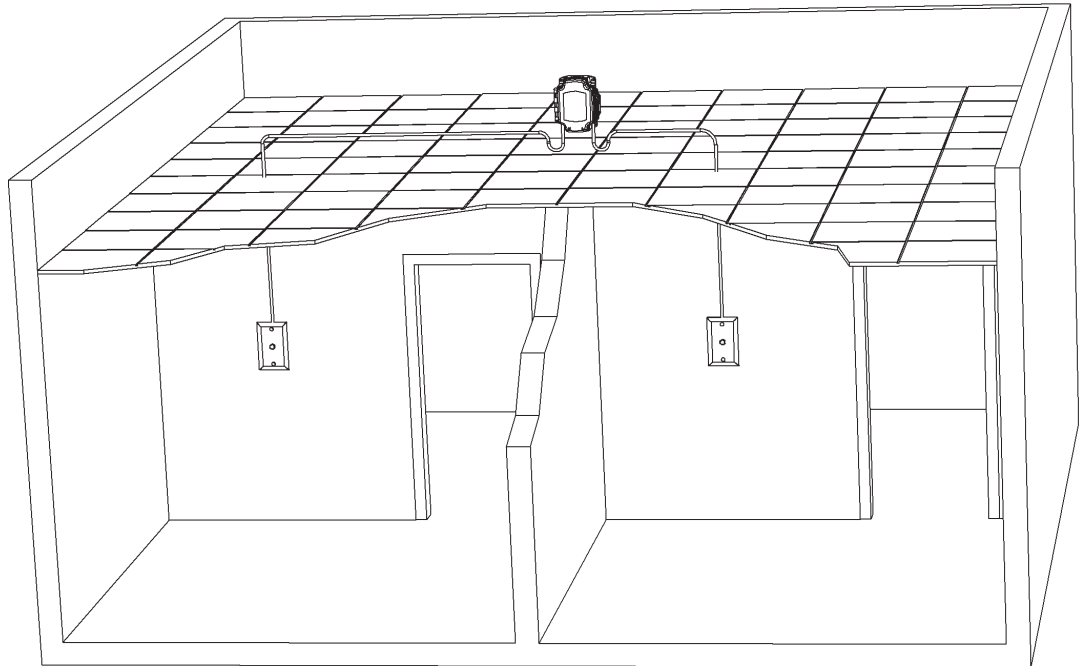

Fig. 13: Measuring duct air filter pressure drop with pressure transmitter and two static pressure probes.

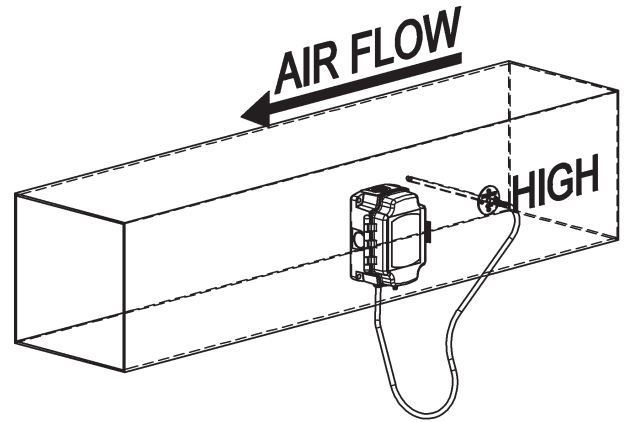

Fig. 14: Measuring duct static pressure with pressure transmitter and static pressure probe

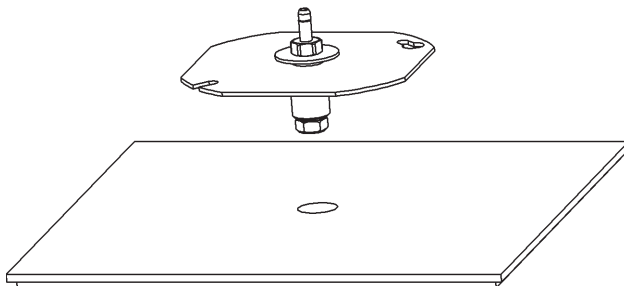

Fig. 15: Exploded view drawing of ceiling static pressure pickup port, BAPI ZPS-ACC05, showing how to mount in ceiling tile.