

Wiring

BAPI recommends using twisted pair of at least 22AWG and sealant filled connectors for all wire connections. Larger gauge wire may be required for long runs. All wiring must comply with the National Electric Code (NEC) and local codes. Do NOT run this device's wiring in the same conduit as AC power wiring of NEC class1 or NEC class 2, NEC class 3 or with wiring used to supply highly inductive loads such as motors, contactors and relays.

BAPI's tests show that fluctuating and inaccurate signal levels are possible when AC power wiring is present in the same conduit as the signal lines. If you are experiencing any of these difficulties, please contact your BAPI representative

BAPI does not recommend wiring the sensor with power applied as accidental arcing may damage the product and will void the warranty

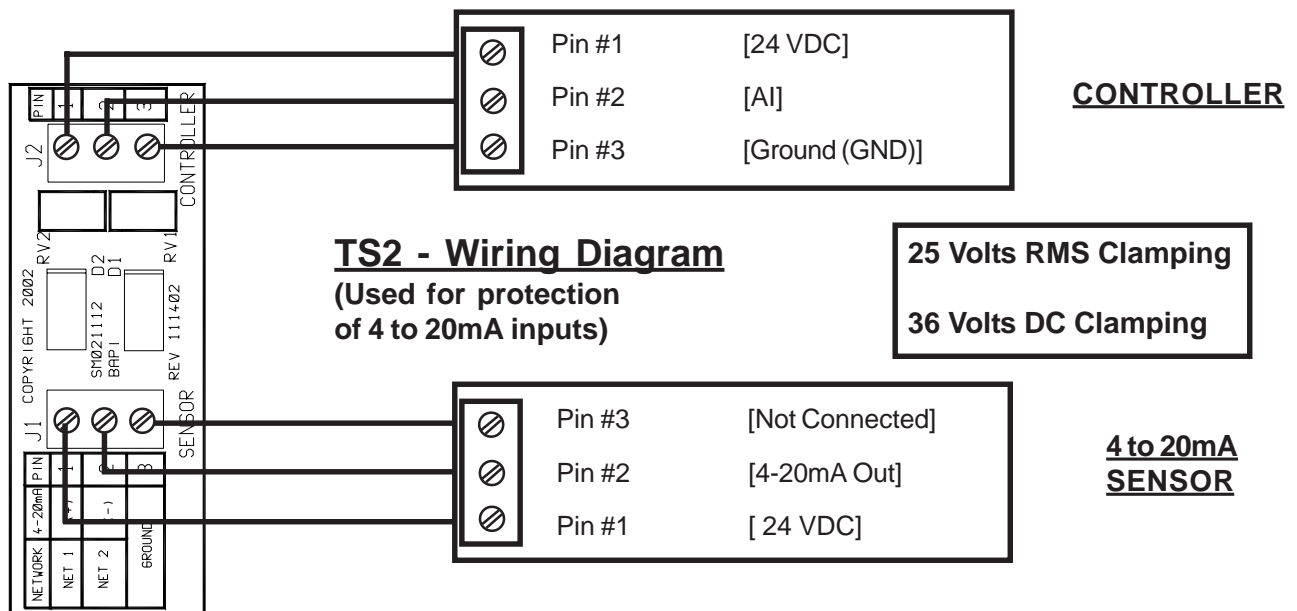
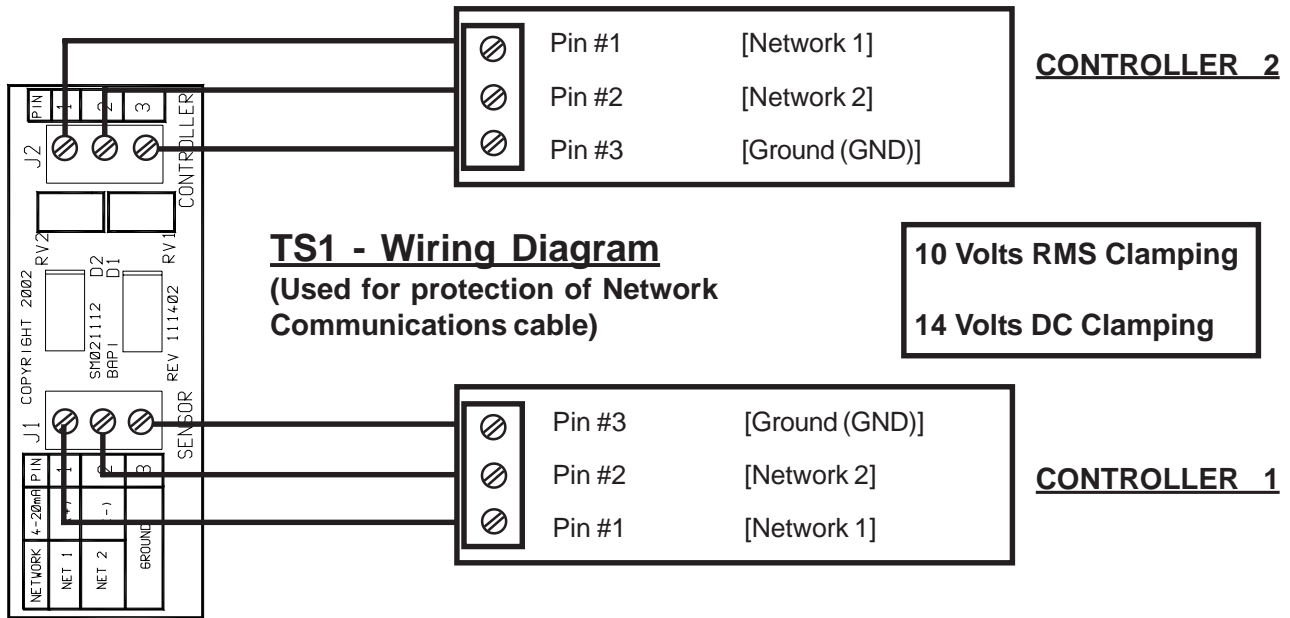

Specifications subject to change without notice.