

Termination

BAPI recommends using twisted pair of at least 22AWG and sealant filled connectors for all wire connections. Larger gauge wire may be required for long runs. All wiring must comply with the National Electric Code (NEC) and local codes.

Do NOT run this device's wiring in the same conduit as AC power wiring of NEC class 1, NEC class 2, NEC class 3 or with wiring used to supply highly inductive loads such as motors, contactors and relays. BAPI's tests show that fluctuating and inaccurate signal levels are possible when AC power wiring is present in the same conduit as the signal lines. If you are experiencing any of these difficulties, please contact your BAPI representative



BAPI does not recommend wiring the sensor with power applied as accidental arcing may damage the product and will void the warranty

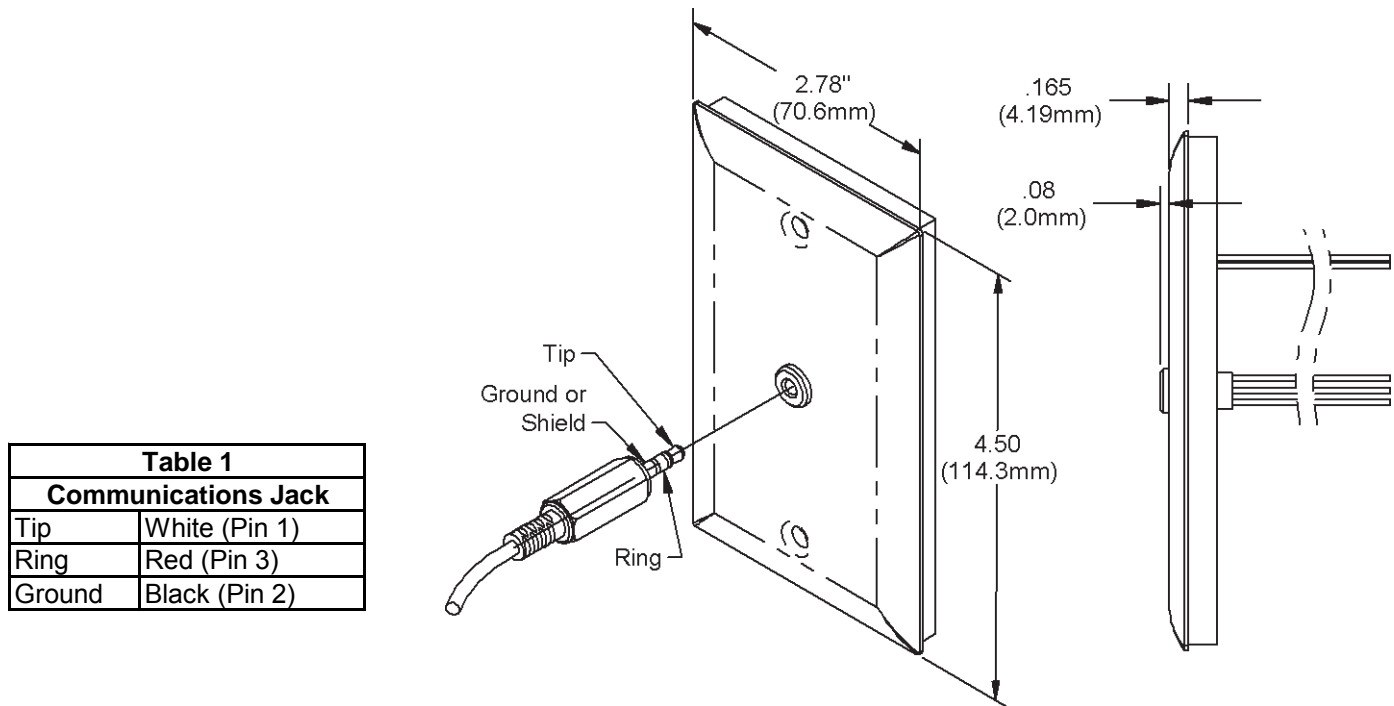

Figure 1: Wall Plate with Communications Jack

Terminate the sensor wires to your controller wires using BAPI sealant filled connectors. The foam on the back of the wall plate seals the wall and insulates the plate from the wall

Tip	White (Pin 1)
Ring	Red (Pin 3)
Ground	Black (Pin 2)

Thermistor		Platinum RTD		
3K	Yellow/Black			
10K-2	Yellow/Yellow			
10K-3	Yellow/Red			
10K3(11K)	Yellow/Blue			
20K	White/White	100Ω	Single Point Two Wire Red/Red	Single Point Three Wire Red/Red/Black
100K	Yellow/White	1,000Ω	Orange/Orange	Orange/Orange/Black

*Some items may not be CE compliant, call BAPI for additional information.

Specifications subject to change without notice.

Troubleshooting**Possible Problems:**

Controller reports higher than actual temperature

Possible Solutions:

-Confirm that the input is set up correctly in the controller software.
-Verify that the wires are not electrically shorted (thermistor) or open (RTD)
-Check wiring for proper termination
-Disconnect the controller wires from the sensor. Measure the temperature sensor's resistance with an Ohm-meter. Verify the sensor's output is correct (see note below). If the measured resistance is different from the temperature table by more than allowable, call BAPI technical support.

Controller reports lower than actual temperature

-Confirm that the input is set up correctly in the controller software.
-Verify that the wires are not electrically open (thermistor) or shorted (RTD)
-Check wiring for proper termination
-Disconnect the controller wires from the sensor. Measure the temperature sensor's resistance with an Ohm-meter. Verify the sensor's output is correct (see note below). If the measured resistance is different from the temperature table by more than allowable, call BAPI technical support.

Communications jack is not working correctly

-Check wiring for proper termination

Compare the readings to the appropriate temperature table on the BAPI website:

<http://www.bapihvac.com>

Click on the sensor bar, then on the table needed.

Mounting

Mounting hardware is provided for both junction box and drywall installation.

Junction Box

1. Pull the wire through the wall and out of the junction box, leaving about six inches free.
2. Terminate the unit according to the guidelines in **Termination** on page 1.
3. Secure the plate to the box using the #6-32 x 1/2 inch mounting screw provided or with Security screws which are sold separately. (Order BA/SP632x1 — Spanner Security Screws, 6-32x1" (box 50) and BA/SPBIT — Spanner Bit for Spanner Security Screws)

Drywall Mounting

1. Place the plate against the wall where you want to mount the sensor.
2. Using a pencil mark out the two mounting holes.
3. Drill two 3/16" holes in the center of each marked mounting hole. Insert a drywall anchor into each hole.
4. Cut hole between the two mounting holes that clears the apparatus mounted on the plate..
5. Pull the wire through the wall hole cut in step 4, leaving about six inches free.
6. Terminate the unit according to the guidelines in **Termination** on page 1.
7. Secure the plate to the drywall anchors using the #6 x 1 inch mounting screws provided.

Specifications subject to change without notice.

Figure 2: Adapter Bracket Mounting

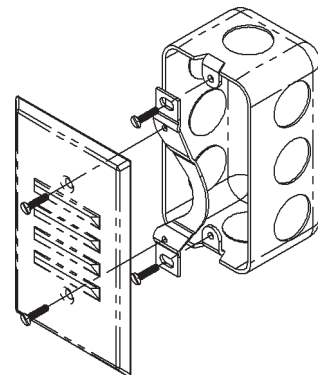

Note: Some wall plates require a mounting adapter-bracket for J-Box's as shown in the diagram.