

592 Theory of Operation

The 592 sensor is a two terminal integrated-circuit temperature sensor. The 592 provides an output current directly proportional to absolute temperature. When the temperature of the 592 sensor changes one-Kelvin (one-degree Celsius), then the current through the 592 changes by 1uAmp. 77° Fahrenheit (25° Celsius) is 298.2 Kelvins and the output current from the 592 sensor is 298.2uAmp. Initial accuracy of the 592 temperature sensor is $\pm 8.1^\circ$ Fahrenheit ($\pm 4.5^\circ$ Celsius) at 77° Fahrenheit (25° Celsius).

Since most meters that field technicians use cannot accurately measure currents this low, BAPI recommends that a 10K Ω 0.1% resistor be placed between the sensor output and ground. The 10K Ω resistor changes the current into a voltage that varies 0.01 volts per one degree Celsius temperature change; the voltage at 77°F is 2.982 VDC. Resistors with other tolerances can be used, but you will have greater temperature uncertainty, see the 10K Ω uncertainty table;

BAPI provides two styles of humidity probe with a 592 sensor, one with and one without the 10,000 ohm 0.1% resistor. The one with the resistor has three wires - red, black and white. The one without the resistor has two wires - red and black.

10K Ω uncertainty Table	
Tolerance	Temperature uncertainty
0.1%	$\pm 8.64^\circ\text{F}$
1%	$\pm 13.47^\circ\text{F}$
5%	$\pm 34.93^\circ\text{F}$

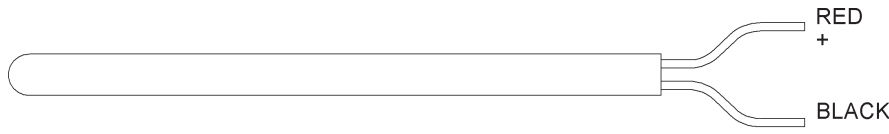

Fig. 1:
592 2-wire



Fig. 2:
592 with 10K resistor

Termination

Table 2: 592 2-Wire Sensors

1. Install a 10K Ω 0.1% resistor from the controller's analog input to the controller's ground or common.
2. If you are using a separate DC power supply, connect the power supply's negative terminal to the controller's ground or common..
3. Connect the 592 sensor's black wire to the controller's analog input.
4. Connect the 592 sensor's red wire to 5 to 30 VDC.

Table 3: 592 3-Wire Sensors

1. All BAPI BA/592-10K, 3-wire, sensors have a built in 10K Ω 0.1% resistor.
2. If you are using a separate DC power supply, connect the power supply's negative terminal to the controller's ground or common..
3. Connect the 592 sensor's black wire to the controller's ground or common.
4. Connect the 592 sensor's white wire to the controller's analog input.
5. Connect the 592 sensor's red wire to 5 to 30 VDC.

Specifications subject to change without notice.

Temperature Measurement Offsetting

All BA/592 sensors will have the following information provided on a label:

Therm Reading _____

The actual temperature reading according to a thermometer that is certified traceable to recognized standards by the National Institute of Standards and Technology (NIST).

Sensor Reading _____

The temperature reading according to the AD592 sensor. The output is dropped across a 10KΩ 0.1%, read in mV and converted to a Fahrenheit temperature.

Offset _____

The difference between the Thermometer Reading and the Sensor Reading

To correct the Sensor Reading, simply add the offset value to the sensor reading so that it equals the thermometer reading.

e.g. Therm Reading = 74.6, Sensor Reading = 73.0, Offset = +1.6
Correction: Add (+1.6) °F to the sensor for an accurate reading: 73 + 1.6 = 74.6°F

e.g. Therm Reading = 75.4, Sensor Reading = 77.2, Offset = -1.8
Correction: Add (-1.6) °F to the sensor for an accurate reading: 77.2 + (-1.8) = 75.4°F

Mounting for 592 Temperature Sensor Products

The BAPI 592 temperature sensor becomes the basis for many products. Here are some examples with mounting instructions.

Junction Box or No Box Units Indoors

The junction box mount is intended for indoor mounting in equipment rooms, plenums or occupied spaces. The figures below show a typical junction box mounting in an air duct. BAPI recommends using #8 sheet metal screws that need 1/8-inch pilot holes to attach the sensor to the duct. After placing the sensing element in the duct, secure the mounting flange to the duct; center the blue plastic fitting holding the probe in the mounting hole. Make sure that the foam seals the hole; do not over tighten the screws. No box units use the same mounting holes as Junction Box units.

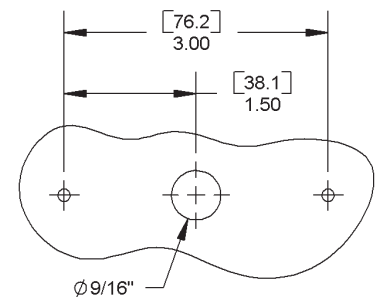
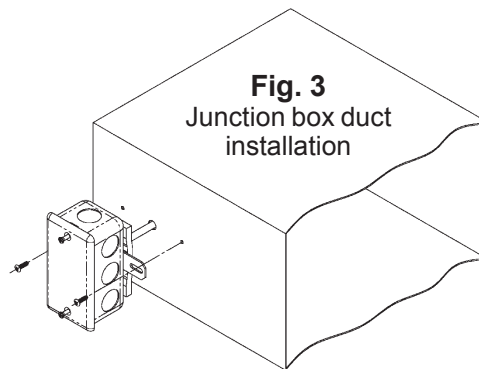

Weatherproof Box Units Indoors

The weatherproof box is intended for outdoor or equipment room mounting. Use the mounting tabs provided to mount the weatherproof box as shown in the figure below. **DO NOT** drill screw holes through the back wall of the box, this destroys the integrity of the box and may void the warranty. The figures below show a typical weatherproof box mounting in an air duct. BAPI recommends using #8 sheet metal screws that need 1/8-inch pilot holes to attach the sensor to the duct. After placing the sensing element in the duct, secure the mounting tabs to the duct; center the blue plastic fitting holding the probe in the mounting hole. Be sure that the foam seals the hole; do not over tighten the screws. Place the foam gasket between the cover and the box before securing the cover in place with the screws provided. To keep water out of the box, be sure to coat the threads of the box plugs or conduit connectors with caulk before screwing them into the waterproof box.

Fig. 5
Weatherproof
box mounting
tabs

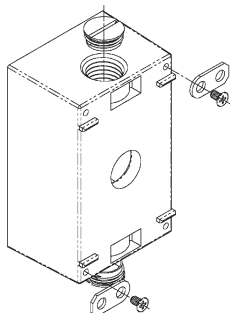

Fig. 6
Weatherproof
box mounting
holes

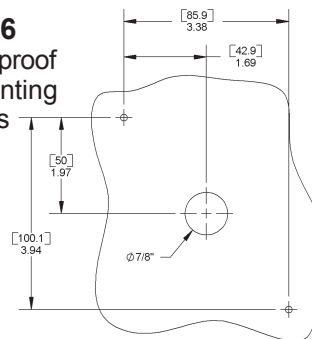
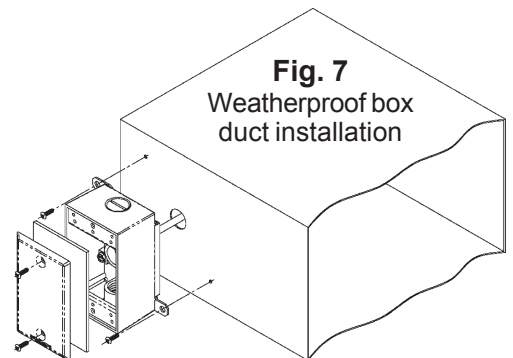

Fig. 7
Weatherproof box
duct installation



Mounting for 592 Temperature Sensor Products continued...

IP-66 EU Enclosure Indoors

The IP-66 enclosure is made from ABS plastic for indoor applications and a UV light stabilized plastic for outdoor applications or indoor applications exposed to direct sun light. The figures below show a typical IP-66 enclosure mounting in an air duct. BAPI recommends using #8 sheet metal screws that need 1/8-inch pilot holes. After placing the sensing element in the duct, secure the mounting feet to the duct; center the blue plastic fitting holding the probe in the mounting hole. Do not over tighten the screws but be sure that the foam insulation makes an airtight seal. Tighten the lid to two clicks when you are finished making terminations.

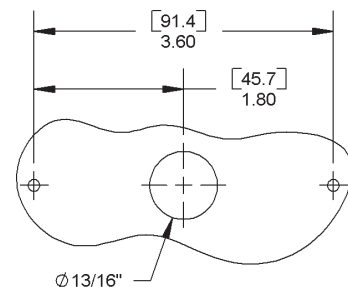
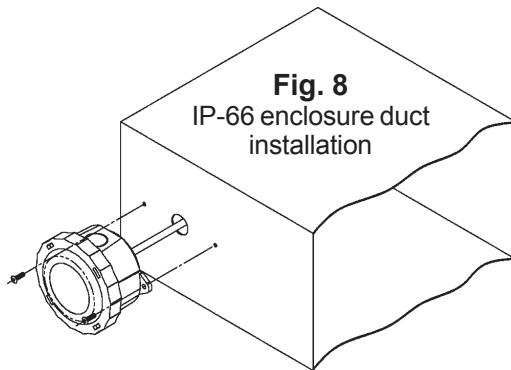

Fig. 9
IP-66 enclosure mounting holes

IP-66 EU Enclosure and Weatherproof Box Outdoors

Do not mount in direct sunlight, preferably mount on the north side of the building. Install with the sensor probe pointed down. For best correlation with the local weather bureau's temperature, position the end of the probe between four feet and six and one-half feet above the ground. Drill a hole through your mounting surface as shown in the figures below. Mount the unit to the surface with a wiring knock out centered over the wiring hole. Pull the wiring into the unit and terminate using sealant filled connectors. Best practice is to caulk the wiring hole after the wiring is installed. Be sure that the foam on the back of the unit makes a good weather tight seal. Use the mounting tabs provided to mount the weatherproof box as shown in the figure below. **DO NOT** drill screw holes through the back wall of the box, this destroys the integrity of the box and may void the warranty. Note: Air temperature units are shown. Temperature and humidity units are available in double gang weatherproof boxes only. To keep water out of the box, be sure to coat the threads of the box plugs or conduit connectors with caulk before screwing them into the waterproof box.

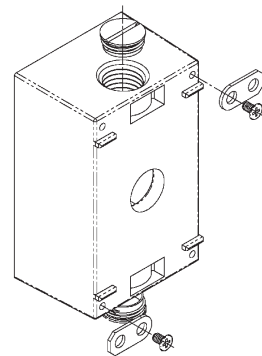

Fig. 13: Weatherproof box enclosure mounting tabs

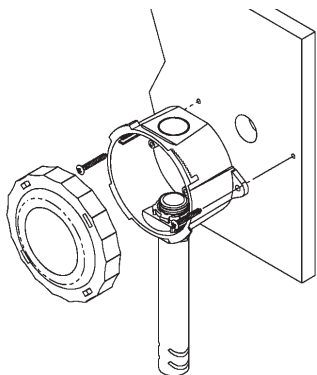

Fig. 10: Outdoor Air/IP-66 rated enclosure installation

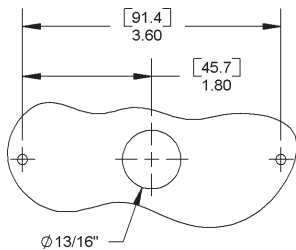

Fig. 11
IP-66 rated enclosure mounting holes

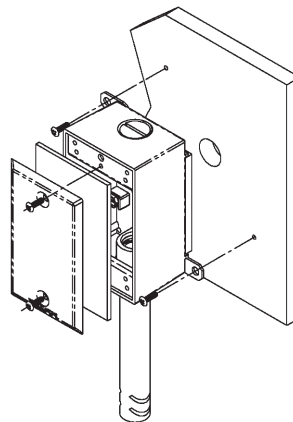

Fig. 12
Outdoor Air/Weatherproof box installation

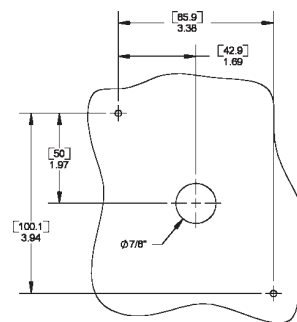

Fig. 14: Weatherproof box enclosure mounting holes

Specifications subject to change without notice.

Mounting for 592 Temperature Sensor Products continued...

Immersion Sensor

Place the thermowell into the pipe nipple using Teflon tape and/or pipe dope. Tighten securely but do not over torque. Insert the immersion sensor into the well with the blue plastic fitting screwing into the opening on the well. Tighten the immersion sensor snugly by hand without too much torque. Make sure that the tip of the immersion sensor is in contact with the bottom of the well. The unit is designed so that the temperature probe moves slightly into the junction box as the sensor hits the bottom of the well. The figure shows a junction box, but weather-proof boxes and IP66 rated enclosures may be used as well.

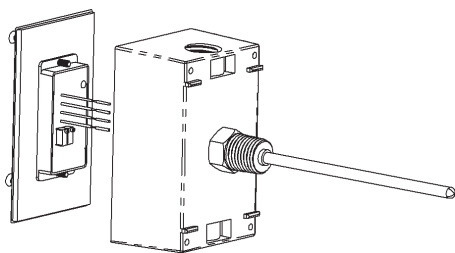

Fig. 15

T1K transmitter mounted to a Weatherproof box cover and Weatherproof box with an immersion probe

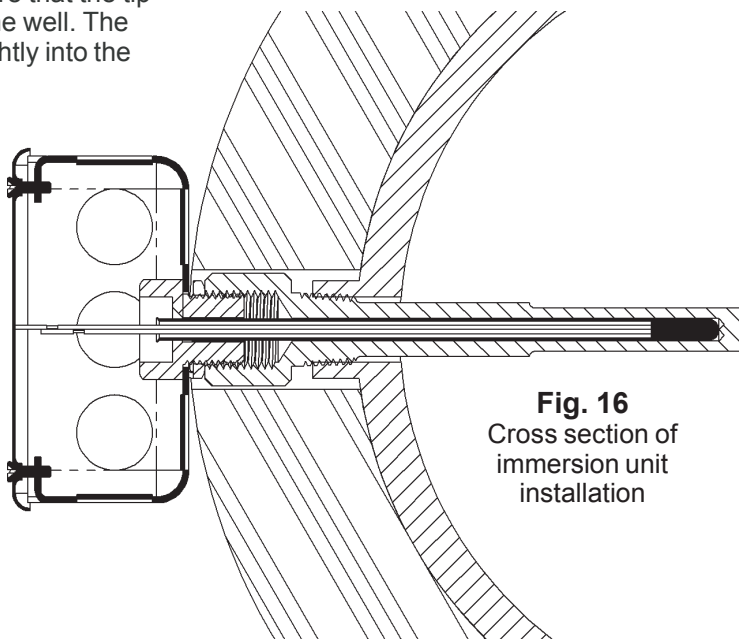

Fig. 16
Cross section of immersion unit installation

Spring-Loaded Strap Unit

The spring-loaded strap sensor is used when a large section of insulation cannot be removed from a pipe. The spring-loaded strap sensor accommodates insulation of up to two inches thick. Cut a 1 1/4 inch diameter hole in the insulation and remove the insulation from the hole down to the bare pipe. Be sure to remove all insulation and debris from the hole. Place the copper pad on the end of the spring-mounted foam into the hole; make sure it makes good physical contact with the pipe.

Tighten the straps until the strap-mounting bracket contacts the insulation. The spring-loaded strap on sensor is sized for pipe diameters of 5 to 12.5 inches, including the insulation.

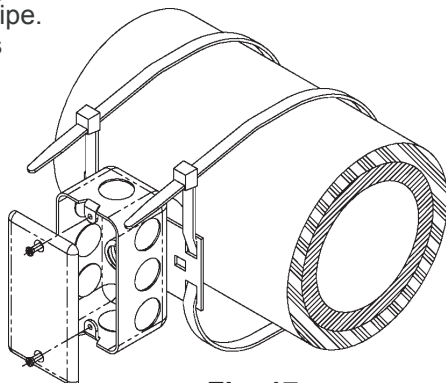

Fig. 17

Spring-Loaded Strap installation

Clamp On Strap Unit

Place the clamp-on sensor on bare pipe, or a section of pipe with the insulation removed. Make sure that the copper pad on the foam is in good physical contact with the pipe. Snug the straps so that the assembly does not rotate around the pipe when moderate pressure is applied to the junction box. Do not over tighten. You may place pipe insulation over the whole assembly. The clamp-on strap sensor is sized for bare pipes of 2 to 4.5 inches in diameter. Add another pipe clamp if needed.

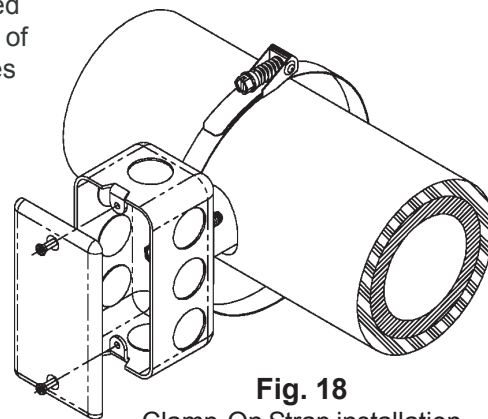

Fig. 18

Clamp-On Strap installation

Specifications subject to change without notice.

Mounting for 592 Temperature Sensor Products continued...

RPFEP and FEP Indoors

Mount the WP or the IP-66 style enclosure as shown in the figures below. Mount with the wire connector down. Route the temperature probe to the spot where you wish to measure the temperature. Best practice is to tie down the wire every two feet. Make sure to caulk the upper screw in plug on the WP enclosure. Center mounting hole shown is only used if you are wiring through the mounting surface.

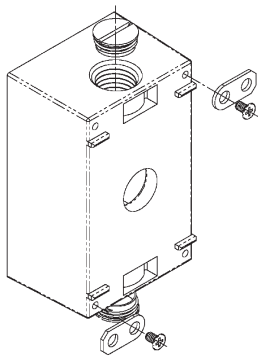

Fig. 19
Weatherproof box
mounting tabs

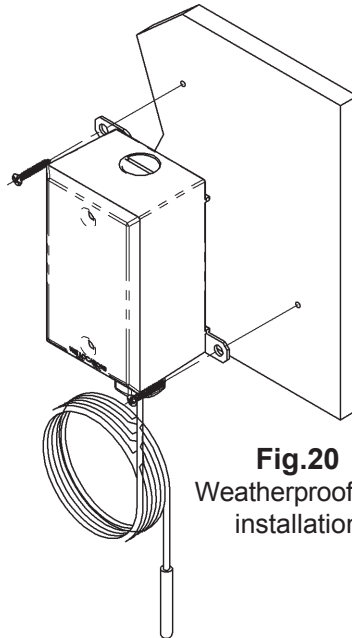

Fig. 20
Weatherproof box
installation

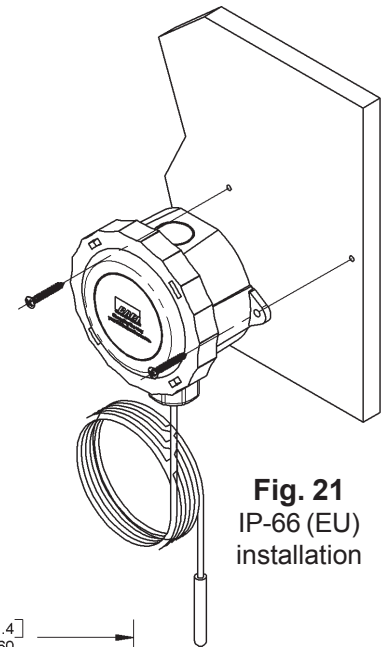

Fig. 21
IP-66 (EU)
installation

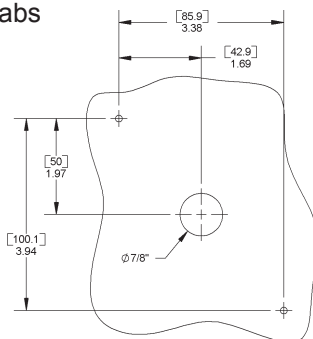

Fig. 22
Weatherproof box mounting holes

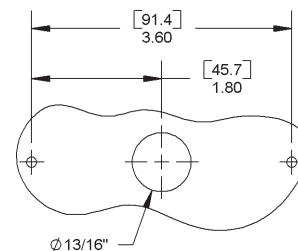

Fig. 23
IP-66 enclosure mounting holes

Specifications subject to change without notice.



Troubleshooting

GENERAL TROUBLESHOOTING AND POSSIBLE SOLUTIONS

- Determine that the input is set up correctly in the controller's and building automation software.
- Check wiring for proper termination
- Check for corrosion at either the controller or the sensor. Clean off the corrosion, re-strip the interconnecting wire and reapply the connection. In extreme cases, replace the controller, interconnecting wire and/or sensor.
- Label the terminals that the interconnecting wires are connected to at the sensor end and the controller end. Disconnect the interconnecting wires from the controller and the sensor. With the interconnecting wires separated at both ends measure the resistance from wire-to-wire with a multimeter. The meter should read greater than 10 Meg-ohms, open or OL depending on the meter you have. Short the interconnecting wires together at one end. Go to the other end and measure the resistance from wire-to-wire with a multimeter. The meter should read less than 10 ohms (22 gauge or larger, 250 feet or less). If either test fails, replace the wire.

592 SENSOR TROUBLESHOOTING

Note: The BAPI crimp-on sealant filled connectors have a convenient hole opposite the wire opening to insert a meter probe for measurements.

- 1) Measure the sensible temperature at the sensors location using an accurate temperature standard.
- 2) Set your meter to the Volts setting.
- 3) Measure from the controller ground (black sensor lead) to the 592's power lead (red sensor lead) for +5 to +30 VDC.
- 4) Set your meter to the mV setting.
 - a) For two wire units place a 10KΩ resistor between the sensors black lead and the return wire to the controller. Measure and record the voltage across the resistor.
 - b) For three-wire units measure and record the voltage from the black lead to the white lead.
- 5) Using Table 4, if the sensor voltage is greater or less than 0.050VDC from the expected voltage measurement, call BAPI technical support.
- 6) If the sensor reads properly, verify that the controller is operating correctly.
- 7) If the sensor reads improperly, determine if the sensor is exposed to an external source different from the measured environment (conduit draft).

Temperature		592 Semiconductor	
°F	°C	Output Current uA	Output Voltage across 10KΩ
50	10	283.2	2.832
60	15.56	288.8	2.888
62	16.67	289.9	2.899
64	17.78	291	2.91
66	18.89	292.1	2.921
68	20	293.2	2.932
70	21.11	294.3	2.943
72	22.22	295.4	2.954
74	23.33	296.5	2.965
76	24.44	297.6	2.976
78	25.56	298.8	2.988
80	26.67	299.9	2.999
82	27.78	301	3.01
84	28.89	302.1	3.021
86	30	303.2	3.032
88	31.11	304.3	3.043
90	32.22	305.4	3.054
100	37.78	311	3.11

Specifications subject to change without notice.