

Product Identification

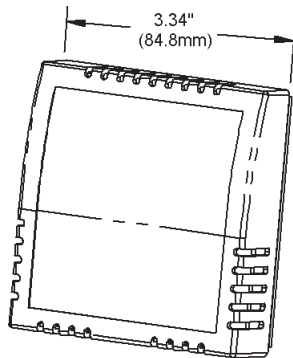

Fig. 1
Room Unit

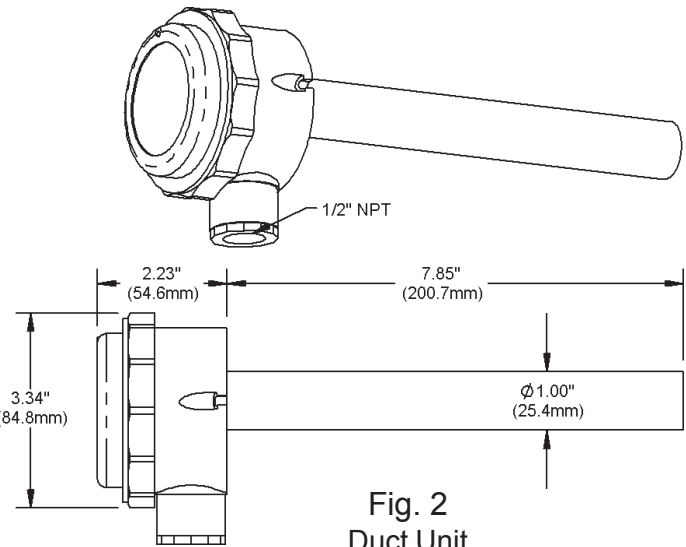
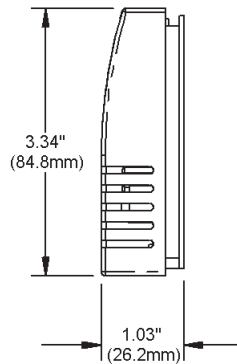
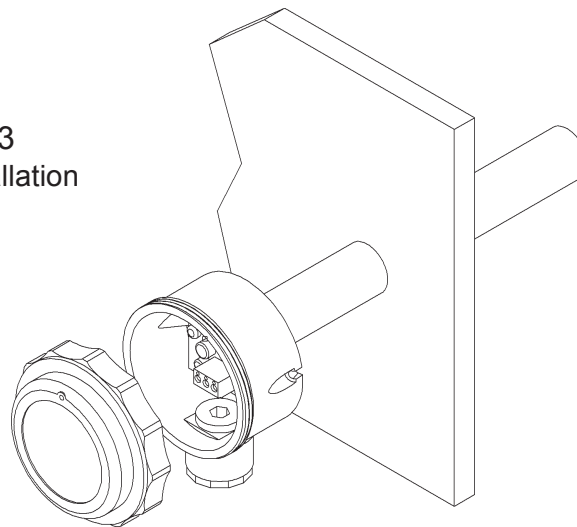

Fig. 2
Duct Unit

Mounting

Fig. 3
Duct Installation



DUCT INSTALLATION:

1. The duct sensor should be mounted in the return air duct of the area or areas to be controlled in an accessible location suitable for maintenance.
2. Although the sensor has a filter, locations such as kitchen hoods should be avoided, where oil and grease will foul the filter.
3. Drill a 1" to 1.5" diameter hole in the duct.
4. Insert probe and secure head using screws provided.
5. Pull wires through conduit fitting and terminate the unit according to the guidelines in **Termination** on page 2.
6. Attach Cover.

Specifications subject to change without notice.

Mounting continued...

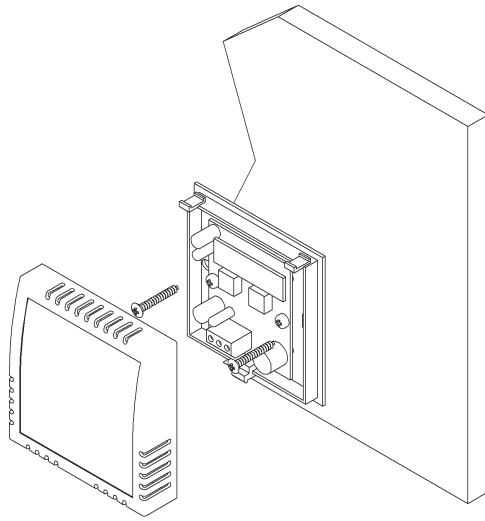

Fig. 4
Room
Installation

ROOM INSTALLATION:

1. The room sensor should be mounted at a height of 5' from the floor of the area to be controlled, away from doors, opening windows, supply grilles or other known disturbances.
2. Place the base plate against the wall where you want to mount the sensor.
3. Using a pencil mark out the two mounting holes and the area where the wires will come through the wall.
4. Drill two 3/16" holes in the center of each marked mounting hole. Insert a drywall anchor into each hole.
5. Drill one 1/2" hole in the middle of the marked wiring area.
6. Pull the wire through the wall and out of the 1/2" hole, leaving about six inches free.
7. Remove base plate knockout and pull the wire through the hole in the base plate.
8. Secure the base to the drywall anchors using the #6 x 1 inch mounting screws provided.
9. Terminate the unit according to the guidelines in **Termination** on page 2.
10. Attach cover by latching it to the top of the base, rotating the cover down and snapping it into place.
11. Secure the cover by tightening the lock-down screw.

Termination

BAPI recommends using twisted pair of at least 22AWG and sealant filled connectors for all wire connections. Larger gauge wire may be required for long runs. All wiring must comply with the National Electric Code (NEC) and local codes.

Do NOT run this device's wiring in the same conduit as AC power wiring of NEC class 1, NEC class 2, NEC class 3 or with wiring used to supply highly inductive loads such as motors, contactors and relays. BAPI's tests show that fluctuating and inaccurate signal levels are possible when AC power wiring is present in the same conduit as the signal lines. If you are experiencing any of these difficulties, please contact your BAPI representative



NOTE: These sensors are not designed or intended for use in safety systems where personal injury may result.

TERMINAL	FUNCTION
1	Ground
2	Power (24V AC or DC)
3	Signal (factory set to 0-10V or 0-5V, see <i>Field Calibration</i>)

JUMPER POSITIONS	FUNCTION
LK1 -	Upper Position = Operate Lower Position = Test (for factory use only)
LK2 -	On = Damped Output Off = Undamped Output

POTENTIOMETERS	FUNCTION
CAL -	Adjusts for "Background" Contamination
SPAN -	Controls Maximum Voltage Output

Fig. 5
AQS Room
configuration

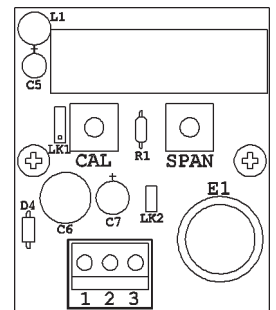
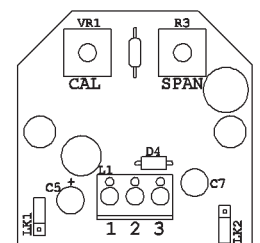

Fig. 6
AQS Duct
configuration



Specifications subject to change without notice.



Characterization of the Air Quality of a Facility

A commonly asked question is “if the signal from the sensor doesn’t directly correspond to a specific ppm level of any one contaminant, how do you correlate the sensor signal to the actual air quality conditions in the facility.” Basically this involves analyzing the output signal of the AQS sensor in relation to specific conditions in the facility. For example, what signal is seen when the facility is unoccupied and maximum outside air is being brought in? This signal is probably a good indicator of the optimum air quality achievable for the facility. Conversely, the signal level seen when the facility is fully occupied and at minimum (or zero) outside air may be a good indicator of the worst air quality conditions that the facility will experience.

Correlation of AQS sensor output voltage to the air quality conditions of the individual installation is a critical part of the start-up process. The best air quality available in the downtown area of a major city, for example, will contain a much higher level of contaminants than the best air quality available in a rural setting. Because of this, it is necessary to correlate the voltage signal from the sensor to the local air quality conditions that will be considered EXCELLENT, GOOD, FAIR, and POOR.

Note: During shipping the sensor may become contaminated. Typically it will require 1 to 2 days of powered operation before its output becomes stable as dust particles and other contaminants that settled onto the element are burned off.

For best results, the following procedure should be performed after a few days of operation to ensure that the sensor has had an opportunity to “burn-in”. One method of accomplishing the adjustment procedure is based on the concept of “baking out” contaminants and “flushing out” the building. It works as follows:

- Step 1 - Record the signal from the AQS sensor in a history log. Other related items such as outside air temperature and humidity, and return air temperature and humidity, should also be logged in history.
- Step 2 - Heat (bake-out) the area being monitored to above normal temperature conditions to cause interior components (carpets, laminates, etc.) to “outgas” (emit gases) at an accelerated rate. Record history data on the AQS point throughout this stage.
- Step 3 - Continue the bake-out process along with the recording of history data for 24 to 72 hours depending on the building requirements.
- Step 4 - Now flush the building with maximum fresh air for 24 to 72 hours. Also continue logging those history samples throughout the entire process.
- Step 5 - The procedure is complete; analyze all of the retrieved history data. The best (EXCELLENT) air quality voltage will have been measured while the building was being flushed with fresh air. Conversely, the worst (POOR) air quality will have been measured while the building was being baked-out. Extrapolate FAIR and GOOD from this data and from the experience gained from an operational building.

Continued Analysis Over Time

Continued logging and analysis of the air quality signal should be done to track building conditions and learn about trends in the facility. Trends you may look for are: How does the air quality signal change in relation to occupancy? Is the air quality worse when the facility is occupied and the HVAC system is running? This would indicate that the air quality is primarily affected by occupant-produced contaminants. Or, does the air quality get worse during unoccupied times when the HVAC is not operating? This would indicate that building materials and equipment primarily affect air quality conditions. Do changes in air quality coincide with an event (operation of certain equipment, or special occupancy) occurring in the facility?

Because every building will have different factors affecting its air quality, it is essential to continue to analyze the data over time. The trends that will be identified with the AQS sensor will assist you in determining what other measures should be undertaken in the facility.



Field Calibration

Please note, adjustment of the **CAL** potentiometer should be done at a time when the conditions surrounding the air quality sensor are at a minimum contamination (contamination level for minimum fresh air). [Excellent air quality determined in Step 5 on previous page]

5VDC CALIBRATION

1. Apply power to the unit. Wait at least 30 minutes before performing the following steps.
2. Connect a DVM to the output.
3. Remove the jumper from LK2.
4. Turn the CAL potentiometer until the output reads 1 VDC.
5. Position the sensor as shown in figures 3 or 4. Move the jumper on LK1 from the upper position to the lower position.
6. Turn the SPAN potentiometer until the output reads 5VDC.
7. Move the jumper on LK1 from the lower position to the upper one; turn the CAL potentiometer until the output reads 1VDC.
8. Replace the jumper on LK2.
9. Calibration is complete.

10VDC CALIBRATION

1. Apply power to the unit. Wait at least 30 minutes before performing the following steps.
2. Connect a DVM to the output.
3. Remove the jumper from LK2.
4. Turn the CAL potentiometer until the output reads 2VDC.
5. Position the sensor as shown in figures 3 or 4. Move the jumper on LK1 from the upper position to the lower position.
6. Turn the SPAN potentiometer until the output reads 10VDC.
7. Move the jumper on LK1 from the lower position to the upper one; turn the CAL potentiometer until the output reads 2VDC.
8. Replace the jumper on LK2.
9. Calibration is complete.

Troubleshooting

Due to the special nature of the Air Quality Sensor, please contact your BAPI representative for troubleshooting help. General troubleshooting steps that you may do are listed below:

- Determine that the input is set up correctly in the controller's and building automation software.
- Check wiring for proper termination
- Check for corrosion at either the controller or the sensor. Clean off the corrosion, re-strip the interconnecting wire and reapply the connection. In extreme cases replace the controller, interconnecting wire and/or sensor.
- Label the terminals that the interconnecting wires are connected to at the sensor end and the controller end. Disconnect the interconnecting wires from the controller and the sensor. With the interconnecting wires separated at both ends measure the resistance from wire-to-wire with a multimeter. The meter should read greater than 10 Meg-ohms, open or OL depending on the meter you have. Short the interconnecting wires together at one end. Go to the other end and measure the resistance from wire-to-wire with a multimeter. The meter should read less than 10 ohms (22 gauge or larger, 250 feet or less). If either test fails, replace the wire.

Specifications subject to change without notice.