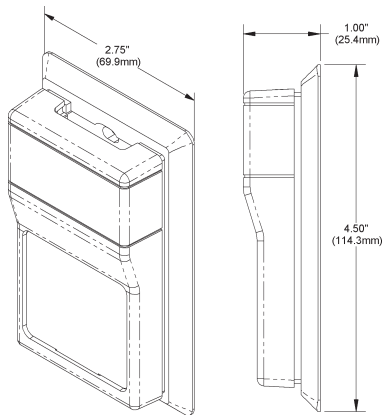
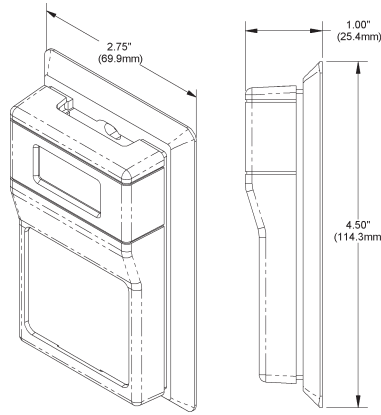
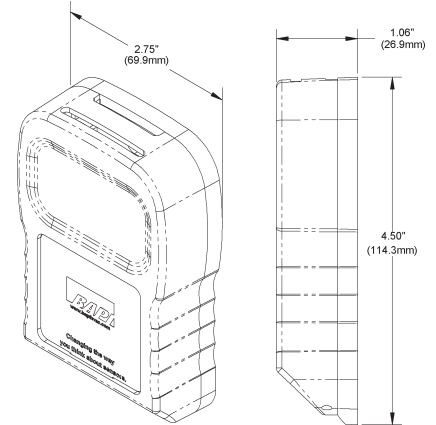
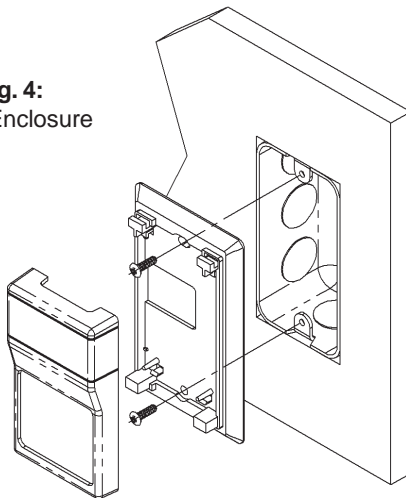
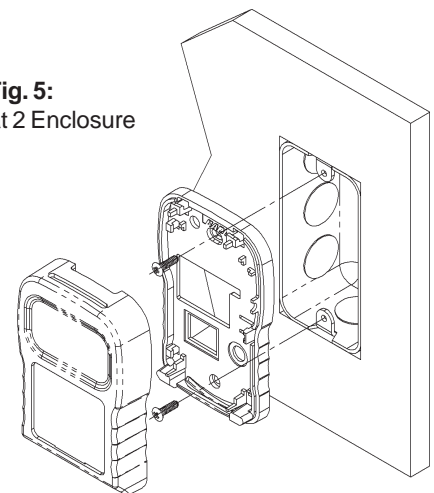

Product Identification**Fig. 1:** Delta Enclosure**Fig. 2:** Delta Enclosure with LCD Display**Fig. 3:** BAPI-Stat 2 Enclosure**Mounting****Fig. 4:** Delta Enclosure**Fig. 5:** BAPI-Stat 2 Enclosure

Mounting hardware is provided for both junction box and drywall installation (junction box installation shown).

**Junction Box**

1. Pull the wire through the wall and out of the junction box, leaving about six inches free.
2. Pull the wire through the hole in the base plate.
3. Secure the base to the box using the #6-32 x 1/2 inch mounting screw provided.
4. Terminate the unit according to the **Terminations** section.
5. Attach Cover by latching it to the top of the base, rotating the cover down and snapping it into place.
6. Secure the cover by backing out the lock-down screws using a 1/16" allen wrench until they are flush with the bottom of the cover.

Drywall Mounting

1. Place the base plate against the wall where you want to mount the sensor.
2. Using a pencil, mark out the two mounting holes and the area where the wires will come through the wall.
3. Drill two 3/16" holes in the center of each marked mounting hole. Insert a drywall anchor into each hole.

Drywall Mounting continued on next page...

*Some items may not be CE compliant, call BAPI for additional information.
Specifications subject to change without notice.

Mounting continued...

4. Drill one 1/2" hole in the middle of the marked wiring area.
5. Pull the wire through the wall and out of the 1/2" hole, leaving about six inches free.
6. Pull the wire through the hole in the base plate.
7. Secure the base to the drywall anchors using the #6 x 1 inch mounting screws provided.
8. Terminate the unit according to the Termination Guidelines section.
9. Attach Cover by latching it to the top of the base, rotating the cover down and snapping it into place.
10. Secure the cover by backing out the lock-down screws using a 1/16" allen wrench until they are flush with the bottom of the cover.

NOTE

In a wall-mount application, the wall temperature and the temperature of the air within the wall cavity can cause erroneous readings. The mixing of room air and air from within the wall cavity can lead to condensation, erroneous readings and premature failure of the sensor. To prevent these conditions, seal the conduit leading to the junction box and seal the hole in the drywall by using an adhesive backed, foam insulating pad (BA/FOAMBACK).

Termination

BAPI recommends using twisted pair of at least 22AWG and sealant filled connectors for all wire connections. Larger gauge wire may be required for long runs. All wiring must comply with the National Electric Code (NEC) and local codes. Do NOT run this device wiring in the same conduit as AC power wiring of NEC class 1, NEC class 2, NEC class 3 or with wiring used to supply highly inductive loads such as motors, contactors and relays.

BAPI's tests show that fluctuating and inaccurate signal levels are possible when AC power wiring is present in the same conduit as the signal lines. If you are experiencing any of these difficulties, please contact your BAPI representative



BAPI does not recommend wiring the sensor with power applied as accidental arcing may damage the product and will void the warranty

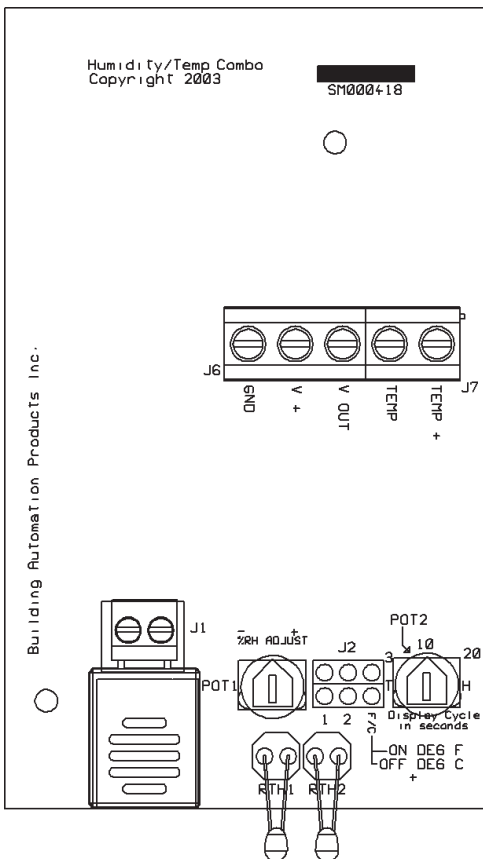

This device can provide 0 to 10 VDC humidity output.

0 to 10VDC Termination

TERMINAL LEGEND

FUNCTION

GND	To Controller Ground [GND or Common]
V+	15 to 40 VDC or 12 to 28 VAC (See Application Note: "Why Use DC Instead of AC Power")
V OUT	0 to 10 VDC Signal [To analog input of controller]
TEMP	Optional Temperature Sensor

Fig. 6:

Room Humidity Unit Circuit Board (shown with optional temperature sensor - RTD or Thermistor)

Specifications subject to change without notice.

Digital Display Settings (for display units only)

°F or °C Indication

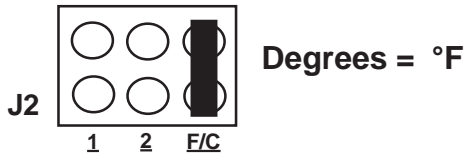

(#1 is Factory Use Only, #2 Not Used)

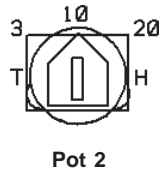
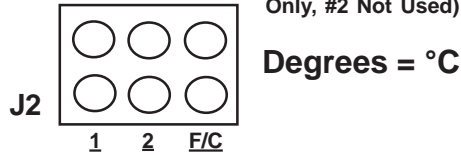

Display Toggle Rate Adjustment between Humidity & Temperature

The pointer on POT 2 indicates the approximate display toggle rate in seconds between temperature and humidity or a constant display of either temperature or humidity.

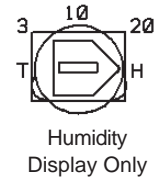
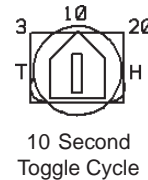
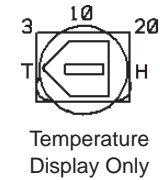

Humidity Offset Adjustment

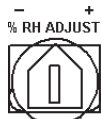

Adjusting the pointer on Pot 1 will offset the humidity either (+) or (-) the amount that is indicated on the LCD display. The Adjustment Range is $\pm 5\%$ RH.

Optional Communication Jack Wiring

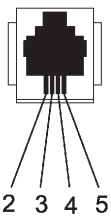
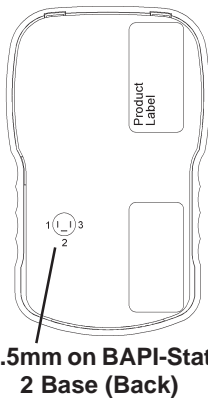
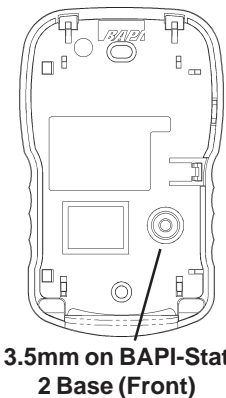
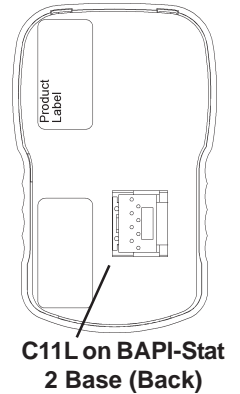
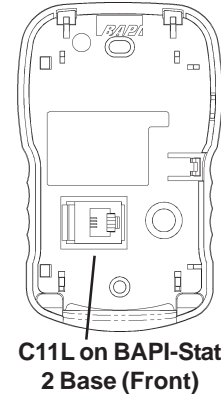
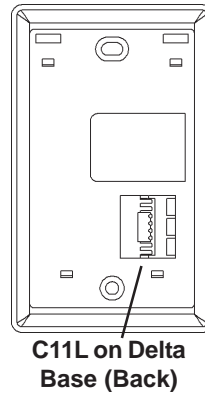
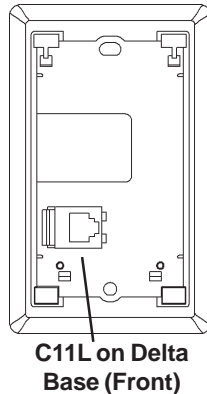
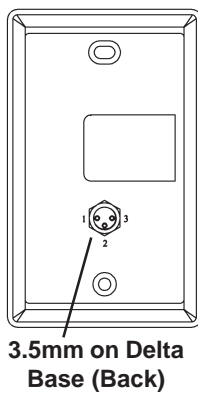
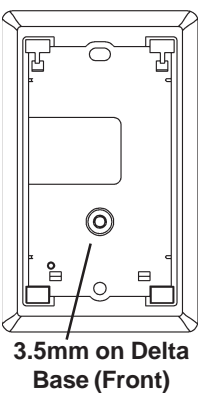

Fig. 7:
C11 Comm Jack

C11 Wiring	
Comm Jack Pin	Wire Color
1	Not Connected
2	Black
3	Red
4	Yellow
5	White or Green
6	Not Connected

Note: Male Jack shown for clarity

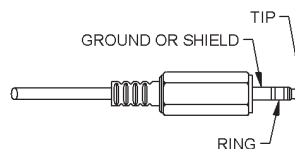

Fig. 8:
C35 Comm Jack

C35 Wiring	
	Wire Color
Ground	Black
Tip	White
Ring	Red

Specifications subject to change without notice.



Room Humidity Sensor, H200-H300 series, (0 to 10V)

Installation & Operating Instructions

8618_ins_room_humidity_0_10_complete

rev. 8/15/08

Diagnostics

General Problems:

Unit will not operate, display is not working

Possible Solutions:

- Check power supply/controller voltage supply
- Disconnect sensor and check power wires for power to the sensor
- Determine that the input is set up correctly in the controller and building automation software.
- Check wiring for proper termination
- Check for corrosion at either the controller or the sensor. Clean off the corrosion, re-strip the interconnecting wire and reapply the connection. In extreme cases, replace the controller, interconnecting wire and/or sensor.
- Label the terminals that the interconnecting wires are connected to at the sensor end and the controller end. Disconnect the interconnecting wires from the controller and the sensor. With the interconnecting wires separated at both ends measure the resistance from wire-to-wire with a multimeter. The meter should read greater than 10 Meg-ohms, open or OL depending on the meter you have. Short the interconnecting wires together at one end. Go to the other end and measure the resistance from wire-to-wire with a multimeter. The meter should read less than 10 ohms (22 gauge or larger, 250 feet or less). If either test fails, replace the wire.

Humidity Related Problems:

Humidity reading is maximum 10V or 100%

Possible Solutions:

- Make sure the sensor is installed properly, and is not shorted. **QUICK CHECK:** Remove sensor, readings should change toward 0%.

Humidity reading is minimum 0V or 0%

- Verify that the humidity sensor is installed. **QUICK CHECK:** Short the sensor terminal block with a wire, readings should change toward 100%.

Humidity reading in software appears to be off more than specified accuracy

- Check all software parameters
- If available, check the sensor against a calibrated control such as a hygrometer
- Determine if the sensor is exposed to an external source different from the room environment (Conduit Draft).

Display will not toggle between Temperature and Humidity

- Check "Toggle Rate Adjustment" pot on the back of the sensor, and make sure the adjustment is correct according to the instructions on Page 3.

Temperature Related Problems:

Temperature sensor in front end software is reading high

Possible Solutions:

- Check if the sensor is damaged
- Make sure wiring is correct
- Disconnect wires and measure temperature sensor with an Ohm meter**.

Temperature sensor in front end software is reading low

- Check if the sensor is damaged
- Verify that wiring is correct
- Disconnect wires and measure temperature sensor with an Ohm meter**.

Sensor reading is significantly off from LCD temperature

- Check control connection
- Disconnect wires and measure temperature sensor with an Ohm meter**.
- Verify the specified thermistor is correct

Display is reading °C instead of °F or °F instead of °C

- Check to make sure J2 is installed correctly according to the instructions on Page 3.

**Compare Temperature readings to the appropriate table on the BAPI website: www.bapihvac.com/Thermistor_OutputTables.htm

Specifications subject to change without notice.