



# Duct & Outside Air Humidity/Temperature Transmitters Humidity (4 to 20mA, 0 to 5V), Temperature (4 to 20mA)

Installation and Operating Instructions

8590\_ins\_hum\_temp\_transcombo\_duct\_out

rev.02/25/11

## Overview

The BA/◆(H200, H300) is a humidity transmitter which comes is 2% or 3% accuracies and an RTD temperature transmitter. It can be ordered for either Duct or Outside air applications with enclosures rated for NEMA 3R or NEMA 4 (IP66). The humidity transmitter can be wired for either 0-5VDC output or a loop powered 4-20mA signal while the temperature transmitter outputs a loop powered 4-20mA signal. The humidity transmitter is powered from 10-35VDC and for the 0-5VDC signal can be powered from a 12-24VAC power source. The temperature transmitter is powered form a 7-40VDC power source.

## Mounting

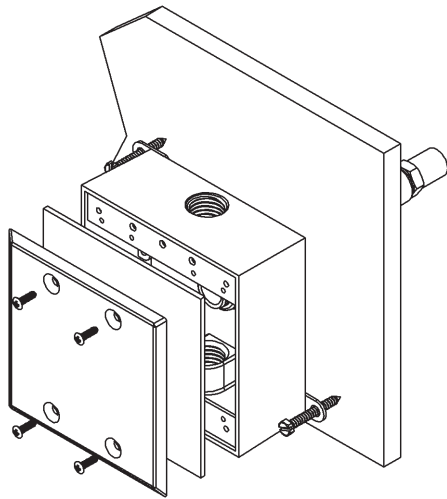

Fig 1: Duct Humidity, NEMA-3R Rated

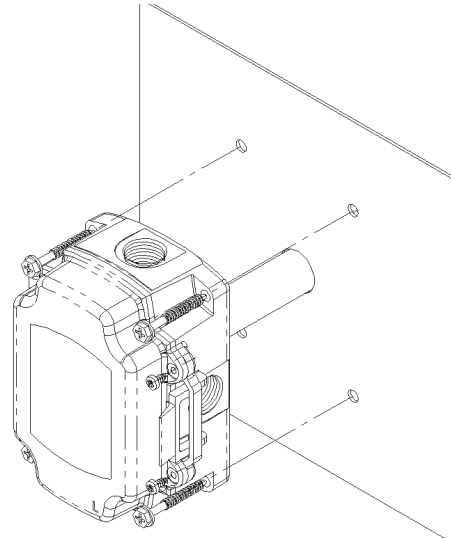

Fig 2: Duct Humidity/BAPI-Box, IP66 Rated

Mount at least 3 duct diameters from humidifiers in the center of the duct wall. Drill a 1 inch hole for the probe in the duct and use two number 8 sheet metal screws to attach the sensor to the duct. Center the probe in its mounting hole. Be sure that the foam seals the hole, do not over tighten the screws.

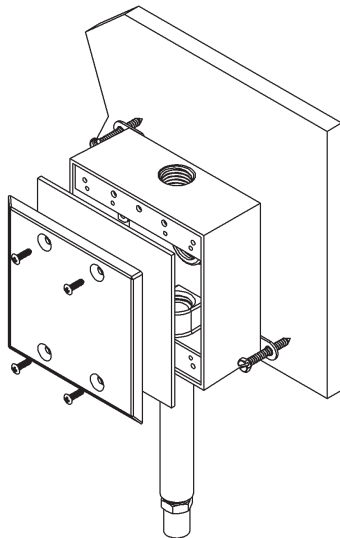

Fig 3: Outside Humidity/Weatherproof

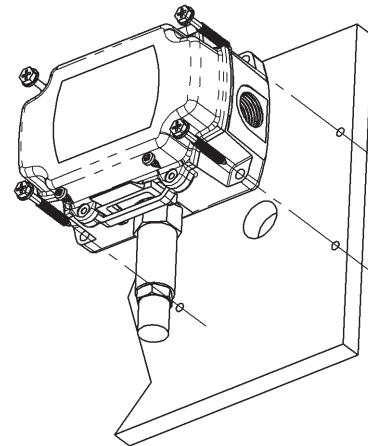

Fig 4: Outside Humidity/BAPI-Box, IP66 Rated

Mount in a permanently shaded area away from windows and doors. Do not mount in direct sunlight. Mount with the sensor probe pointed down. Drill a hole large enough for your sensor cable through your mounting surface. Mount the unit to the surface with the wiring knock out centered over the wiring hole. Pull the wiring into the unit and terminate using sealant filled connectors. Best practice is to seal the wiring hole with insulation after the wiring is installed. Do not use moisture cure caulk such as Silicone, RTV, Latex, Acrylic or Polyurethane based caulk because it will damage the RH Sensor. Be sure that the foam on the back of the unit makes a good weather tight seal.

Specifications subject to change without notice.



# Duct & Outside Air Humidity/Temperature Transmitters Humidity (4 to 20mA, 0 to 5V), Temperature (4 to 20mA)

Installation and Operating Instructions

8590\_ins\_hum\_temp\_transcombo\_duct\_out

rev.02/25/11

## Termination

BAPI recommends using twisted pair of at least 22AWG and sealant filled connectors for all wire connections. Larger gauge wire may be required for long runs. All wiring must comply with the National Electric Code (NEC) and local codes.

Do NOT run this device's wiring in the same conduit as AC power wiring of NEC class 1, NEC class 2, NEC class 3 or with wiring used to supply highly inductive loads such as motors, contactors and relays. BAPI's tests show that fluctuating and inaccurate signal levels are possible when AC power wiring is present in the same conduit as the signal lines. If you are experiencing any of these difficulties, please contact your BAPI representative



BAPI does not recommend wiring the sensor with power applied as accidental arcing may damage the product and will void the warranty



Table 1: Humidity Transmitter Wiring

| Wire color | Purpose            | Note   |
|------------|--------------------|--|
| Yellow     | Temperature Sensor | Factory connection, no customer connection allowed                           |
| Yellow     | Temperature Sensor | Factory connection, no customer connection allowed                           |
| Blue       | Humidity Sensor    | Factory connection, no customer connection allowed                           |
| Blue       | Humidity Sensor    | Factory connection, no customer connection allowed                           |
| White      | Voltage output     | 0 to +5VDC output, To Analog Input of Controller                             |
| Black      | GND (Common)       | 0 to +5VDC Output Ground;<br>4 to 20mA output, To Analog Input of Controller |
| Red        | Power              | 10-35VDC or 12-24VAC for 0-5VDC outputs<br>10-35VDC for 4-20mA outputs       |

Table 2: Temperature Transmitter Wiring

| Wire color                     | Purpose | Note   |
|--------------------------------|---------|--|
| Various-depends on sensor type | Sensor  | Factory connection, no customer connection allowed |
| Various-depends on sensor type | Sensor  | Factory connection, no customer connection allowed |
| Black                          | Output  | 4 to 20mA output, to analog input of Controller    |
| Red                            | Power   | +7 VDC to +40 VDC                                  |

2% and 3%, Humidity Transmitters **Are** Polarity Sensitive as well as Reverse Polarity Protected.

All 4-20mA Temperature Transmitters **Must Be** Powered with a 10 to 35VDC Supply.

Temperature Transmitters **Are Not** Polarity Sensitive and **Must Be** Powered with a 7 to 40VDC Supply.

Specifications subject to change without notice.

Fig 5: Wiring Diagram

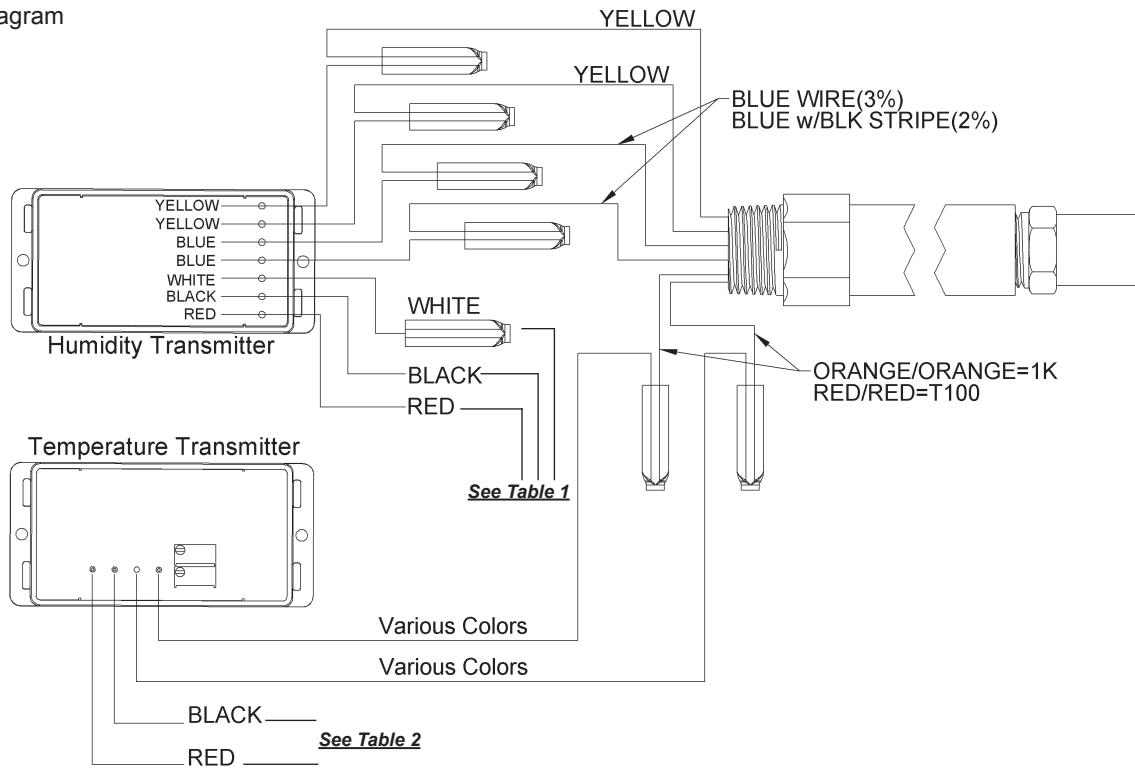

### Diagnostics - Humidity

#### Possible Problems:

Unit will not operate

Humidity reading is maximum 5V or 20mA

Humidity reading is minimum 0V or 4mA

Humidity reading in controller's software appears to be off more than the specified accuracy

#### Possible Solutions:

- Check controller power supply. Common is the same as the Transmitter Power Source Common.
- Disconnect humidity transmitter power wires, check that the wire from the power supply is compatible to Table 1.
- Make sure the humidity sensor is installed properly and is not shorted
- **QUICK CHECK:** Open one of the blue wire connections. Does the reading change? If so, the sensor may be faulty. If not, contact BAPI technical support.
- Verify that the humidity sensor is installed
- **QUICK CHECK:** Short the two blue wire connections with a short piece of wire. Does the reading change? If so, the sensor may be faulty. If not, contact BAPI technical support.
- Check all software parameters
- If available, check the sensor against a calibrated control such as a hygrometer. 2% minimum accuracy is recommended
- Measure the humidity transmitter's output. Using the humidity formula, calculate the output. If it is different from the software reading, contact BAPI technical support.
- Determine if the sensor is exposed to an external source different from the measured environment, (Air Infiltration?)

| Output     | Humidity Formula       |
|------------|------------------------|
| 4 to 20 mA | $\%RH = (mA - 4)/0.16$ |
| 0 to 5 VDC | $\%RH = V/0.05$        |

Specifications subject to change without notice.



# Duct & Outside Air Humidity/Temperature Transmitters Humidity (4 to 20mA, 0 to 5V), Temperature (4 to 20mA)

Installation and Operating Instructions

8590\_ins\_hum\_temp\_transcombo\_duct\_out

rev.02/25/11

## Diagnostics - Temperature

### Problems:

Unit will not operate

Temperature sensor is reading high in controller software

Temperature sensor is reading low in software

**Note:** The temperature surrounding the transmitter must be between -20 and 140°F (-20 and 70°C).

### Possible Solutions:

- Measure the power supply voltage by placing a voltmeter across the transmitter's (+) and (-) terminals. The voltage reading should be between 7 to 40 VDC. If the voltage is above 40 VDC the transmitter is damaged. Fix the power supply so that it is between 7 to 40VDC and replace the transmitter.
- If the voltage measured above is below 7 VDC, disconnect the power wires from the transmitter. Measure the voltage on the power wires by placing a voltmeter from wire to wire. If the measured voltage reading is between 7 to 40 VDC replace the transmitter. If the measured voltage is below 7 VDC fix the power supply
- Determine if the input is set up correctly in the controllers front end software
- Check if the RTD wires are physically open
- \*Measure the physical temperature at the temperature sensor's location using an accurate temperature standard. Disconnect the temperature sensor wires and measure the temperature sensor's resistance with an ohmmeter. Compare the temperature sensor's resistance to the appropriate temperature sensor table on the BAPI web site. (BAPI's web site is found at [www.bapihvac.com](http://www.bapihvac.com); click on the button labeled SENSORS on the left of the screen and then click on the type of sensor you have.) If the measured resistance is incorrect, replace the sensing element. Measure the transmitter current by placing an ammeter in series with the controller input. Set the ammeter to the 200mA range. The current should read according to the equation below. If the transmitter's measured output does not agree with the computed output, replace the transmitter. If both measurements are correct, there is nothing wrong with the sensor and transmitter combination, look elsewhere.
- Determine if the input is set up correctly in the controllers front end software
- Check if the RTD wires are physically shorted
- \*See Section above.

### Temperature Equation

$$T = T_{low} + \frac{(A-4) \times (T_{span})}{16}$$

T = Temperature at sensor

T<sub>low</sub> = Low temperature of span

T<sub>high</sub> = High temperature of span

T<sub>span</sub> = T<sub>high</sub> - T<sub>low</sub>

A = Ammeter reading in mA

Specifications subject to change without notice.



# Duct & Outside Air Humidity/Temperature Transmitters Humidity (4 to 20mA, 0 to 5V), Temperature (4 to 20mA)

Installation and Operating Instructions

8590\_ins\_hum\_temp\_transcombo\_duct\_out

rev.02/25/11

## Filter Care

A sintered filter protects the humidity sensor from various airborne particles that might reduce the sensor's accuracy. Depending on the sensor's location and environment, this filter may need periodic cleaning. To do this, gently unscrew the filter from the probe. Rinse the filter under warm water until clean. Warm soapy water may be used if necessary. Gently replace the filter by screwing it back into the probe. The filter should screw all the way into the probe, or at the most have only one or two threads showing. Hand tighten only. If a replacement filter or replacement probe is needed, call **BAPI** for more information.

## Specifications

### Power:

|                                      |                          |
|--------------------------------------|--------------------------|
| RH-(4 to 20 mA or 0 to 5 VDC output) | 10 to 35 VDC, 22mA max   |
| RH-(0 to 5 VDC output)               | 12 to 24 VAC, 0.53VA max |
| Temp (4 to 20 mA output)             | 7 to 40VDC, 22mA max     |

### Sensor:

|          |              |
|----------|--------------|
| Humidity | Resistive    |
| Temp.    | Platinum RTD |

**Filter:** 100 micron sintered stainless steel

### Accuracy:

|     |                               |
|-----|-------------------------------|
| 200 | 2%, from 15% to 95%RH @77°F   |
| 300 | 3%, from 15% to 95%RH @77°F   |
| RTD | ±0.55°F (0.31°C) @ 32°F (0°C) |
|     | High accuracy units available |

### Output:

|          |                                   |
|----------|-----------------------------------|
| Humidity | 4-20mA or 0-5VDC = 0-100%RH       |
| Temp.    | 4-20mA = specified range on order |

### Impedance:

|         |             |
|---------|-------------|
| Current | 700Ω@ 24VDC |
| Voltage | 10KΩ        |

### Enclosures material:

|    |                             |
|----|-----------------------------|
| WP | Cast Aluminum               |
| BB | Polycarbonate, UV resistant |

### Enclosures Ratings:

|    |                       |
|----|-----------------------|
| WP | NEMA-3R               |
| BB | NEMA-4, IP66, UL94V-0 |

### Environmental Ambient Range:

-22° to 158°F, (-30° to 70°C)  
0 to 100% RH

Specifications subject to change without notice.