



Product Identification

The Indoor Environment Quality output of the BAPI IEQ sensor is 0 to 100% VOC contamination. The VOC contamination is turned into a CO₂ ppm equivalent by multiplying by 2,000. 22.5% VOC contamination is 450 ppm CO₂ equivalent, 50% VOC contamination is 1,000 ppm CO₂ equivalent and 100% VOC contamination is 2,000 ppm CO₂ equivalent. Using the CO₂ equivalent number, ventilate the space according to ASHRAE's Demand Controlled Ventilation algorithm at that CO₂ concentration.

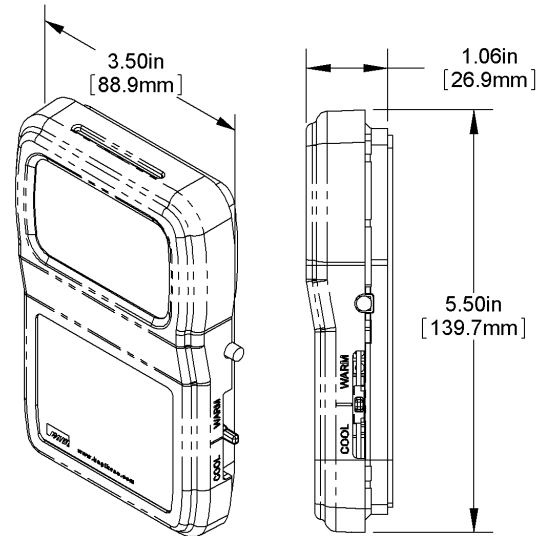

Figure 1: BAPI-Stat 3 Room IEQ Sensor

Specifications

<p>Power: 9 - 35 VDC @ 50 mA Max (9 - 24VDC recommended) for 0 - 5 VDC Outputs 15 - 35 VDC @ 50mA Max (15 - 24VDC recommended) for 0 - 10 VDC Outputs No AC Power</p> <p>Sensing Elements: Humidity – Capacitive Polymer, ±1.8% RH Accuracy Air Quality – Micro-machined Metal Oxide</p> <p>Temperature Sensor Thermistor, RTD or Semiconductor</p> <p>Mounting: 2" x 4" J-Box or drywall mount – screws provided</p> <p>VOC Detection Range: 0 – 100% (0 to 2,000ppm CO₂ Equivalent)</p> <p>Response Time: Less Than 60 Seconds (after start-up)</p> <p>Start-up Time: 15 minutes</p> <p>Operating Environment: 32 - 122°F (0 - 50°C) 0 – 95%RH non-condensing</p> <p>LCD Display Main Display 3.5 digit numeric (% Contaminant, Temp & Humidity) Occ/Un-occ BAPI Man Icon (Blk=Occupied) Units F, C, %RH & %IEQ</p>	<p>Measurement Offsets (field adjustable) ±5° (F or C) in 0.1° increments ±5% RH in 0.1%RH increments ±5% Contaminants in 0.1% increments</p> <p>Analog Outputs (0-5, 0-10 or 2-10VDC (%RH only), >10KΩ impedance) IEQ Contaminants 0 - 100% RH% 0 – 100% or 35 – 70%RH</p> <p>Override Output Contact SPST Sensor Shorts out direct Temperature sensor (TP+ to TP-) Setpoint Contact In parallel (SET to GND), resistive setpoint only</p> <p>Dimension: 5.50"H x 3.50"W x 1.06"D (139.7 x 88.9 x 26.9 mm)</p> <p>Material: ABS Plastic, Material Rated UL94V-0</p> <p>Certifications: RoHS</p> <p>Warranty Period: Two years from manufacture date</p>
---	--

Note: The VOC contaminant output (IEQ terminal on the circuit card) is scaled for 0 to 100%, equivalent to 0 to 2,000ppm CO₂ for use in an ASHRAE Standard 62.1 Demand Control Ventilation algorithm. The display shows contamination to 250% or an equivalent 5,000ppm CO₂. This allows additional troubleshooting for a building manager to determine if there is a very large VOC contamination when the transmitted output is at its maximum value.

Specifications subject to change without notice.

Mounting

Mounting hardware is provided for both junction box and drywall installation (junction box installation shown).

Junction Box

1. Pull the wire through the wall and out of the junction box, leaving about six inches free.
2. Pull the wire through the hole in the base plate.
3. Secure the plate to the box using the #6-32 x 5/8 inch mounting screws provided.
4. Terminate the unit according to the guidelines in the **Termination** section. (page 3)
5. Mold the foam on the unit's base to the wire bundle to prevent drafts. (see note below)
6. Attach Cover by latching it to the top of the base, rotating the cover down and snapping it into place.
7. Secure the cover by backing out the lock-down screw using a 1/16" Allen wrench until it is flush with the bottom of the cover.

Drywall Mounting

1. Place the base plate against the wall where you want to mount the sensor.
2. Using a pencil mark out the two mounting holes and the area where the wires will come through the wall.
3. Drill two 3/16" holes in the center of each marked mounting hole, DO NOT punch the holes or the drywall anchors will not hold. Insert a drywall anchor into each hole.
4. Drill one 1/2" hole in the middle of the marked wiring area.
5. Pull the wire through the wall and out of the 1/2" hole, leaving about six inches free.
6. Pull the wire through the hole in the base plate.
7. Secure the base to the drywall anchors using the #6 x 1 inch mounting screws provided.
8. Terminate the unit according to the guidelines in the **Termination** section. (page 3)
9. Mold the foam on the unit's base to the wire bundle to prevent drafts. (see note below)
10. Attach cover by latching it to the top of the base, rotating the cover down and snapping it into place.
11. Secure the cover by backing out the lock-down screw using a 1/16" Allen wrench until it is flush with the bottom of the cover.

NOTE: In any wall-mount application, the wall temperature and the temperature of the air within the wall cavity can cause erroneous readings. The mixing of room air and air from within the wall cavity can lead to condensation, erroneous readings and sensor failure. To prevent these conditions, BAPI recommends sealing the conduit leading to the junction box, filling the junction box with fiberglass insulation or sealing the wall cavity.

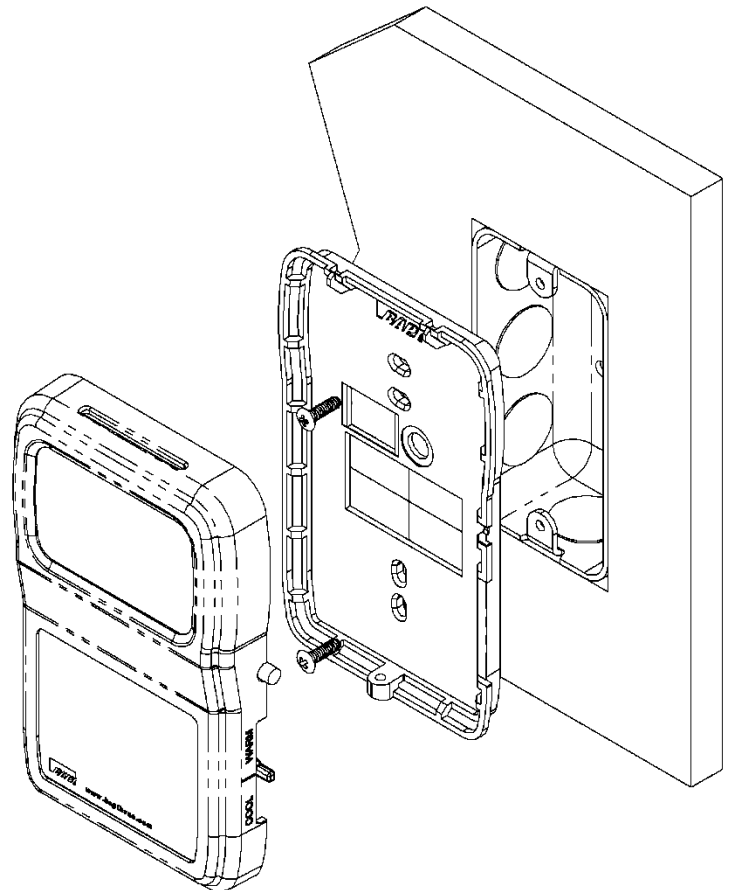

Fig 2: Mounting to a Junction Box

Termination

BAPI recommends using twisted pair of at least 22AWG and sealant filled connectors for all wire connections. Larger gauge wire may be required for long runs. All wiring must comply with the National Electric Code (NEC) and local codes.

Do **NOT** run this device's wiring in the same conduit as AC power wiring of NEC class 1, NEC class 2, NEC class 3 or with wiring used to supply highly inductive loads such as motors, contactors and relays. BAPI's tests show that fluctuating and inaccurate signal levels are possible when AC power wiring is present in the same conduit as the signal lines. If you are experiencing any of these difficulties, please contact your BAPI representative.

BAPI recommends against wiring the sensor with power applied as accidental arcing may damage the product and void the warranty.

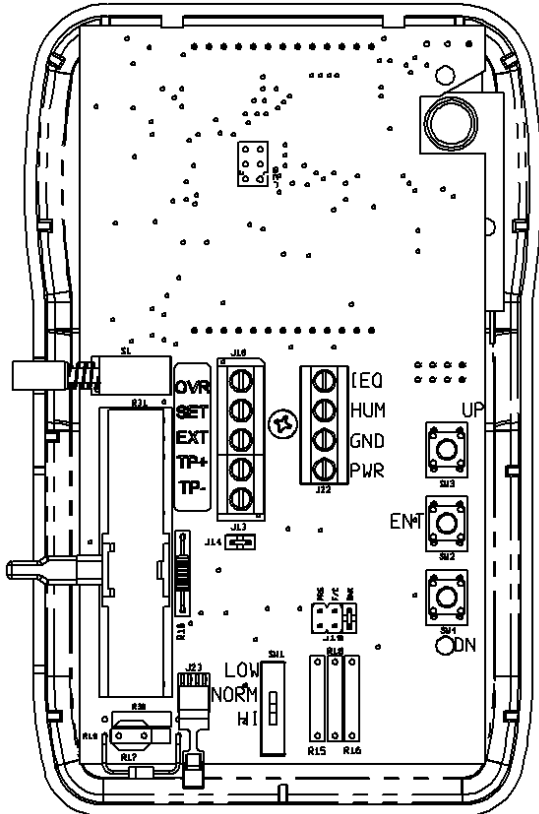

Terminal	Function
OVR	Override Output (Dry Contact Switch). When Override switch is pushed this terminal is connected to GND.
SET	Setpoint output. Referenced to ground.
EXT	External occupied LCD indicator is activated by logic LOW or ground at this terminal.
TP+ & TP-	Temperature Sensor Output (Resistive Output). When a jumper is on J14, TP- is connected to ground, When the jumper is off of J14, the temperature sensor is floating. (Semiconductor TP+ = +, TP- = -)
IEQ	Voltage output IEQ Signal (0 to 100%) referenced to GND
HUM	Voltage output Humidity Signal referenced to GND
GND	To controller Ground [GND or Common]
PWR	Power, referenced to GND 9 - 35 VDC @ 50 mA Max (9 – 24VDC recommended) for 0 – 5 VDC Outputs 15 - 35 VDC @ 50mA Max (15 - 24VDC recommended) for 0 - 10 VDC Outputs

Figure 3: Circuit Board

Note: Unit is not ready for operation until the fifteen-minute start-up time has elapsed. (See Page 6)

Optional Test and Balance Switch

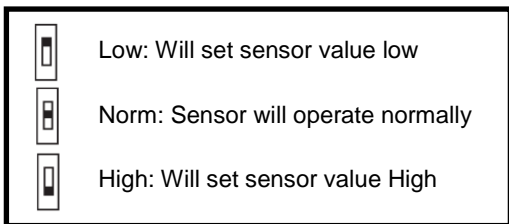

Sensor Type	Low Temp	High Temp
1000 Ω RTD	1.02K Ω (41.2°F)	1.15K Ω (101.5°F)
3000 Ω Thermistor	7.87K Ω (39.8°F)	1.50K Ω (106.8°F)
10K-2 Thermistor	30.1K Ω (34.9°F)	4.75K Ω (109.1°F)
10K-3 Thermistor	26.7K Ω (35.9°F)	5.11K Ω (108.4°F)
10K-3(11K) Thermistor	7.32K Ω (43.7°F)	3.65K Ω (105.2°F)

Figure 4: Test and Balance Switch Operation

Specifications subject to change without notice.



Optional Technician Adjustments

BAPI's IEQ room sensor comes calibrated and ready to operate. In some installations the sensor may not match local instrumentation. The technician adjustment procedure allows °F or °C display units, temperature, humidity and IEQ offsets or display information to be changed at any time.

Removing Ground from Temperature Sensor

In some installations a ground loop may cause erratic temperature readings. Remove the jumper on J14 to eliminate the ground loop and run wires directly from TP+ and TP- to the temperature analog input.

°F or °C display units

Figure 6 and figure 7 show the jumper positions for displayed values of Celsius or Fahrenheit degrees. The jumpers on pins PRG and BNK are omitted for clarity.

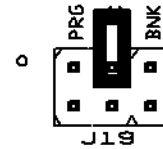

Figure 6: °C

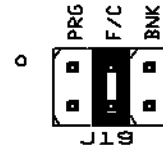

Figure 7: °F

Temperature and Humidity Offsets & Display Information

Figure 8 and figure 9 show how to place the unit into field setup mode. Take the jumper from the BNK terminals and place it on the PRG terminals. The F/C jumper is omitted for clarity.

The display should read P0.

Use the UP/DN buttons (See Figure 10) to select the desired page.

Press and release the ENT button to select the desired page.

Use the UP/DN buttons to adjust the desired value

Press and release the ENT button to save the change and return to the page display.

Adjust another page or place the jumper into normal operation.

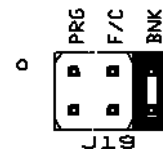

Figure 8:
Normal Operation

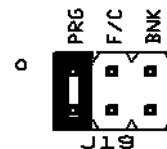

Figure 9:
Programming Setup

Parameter	Page Designator	Adjustment																																							
Temperature Offset	P0	±5° in 0.1° increments																																							
Relative Humidity Offset	P1	±5% in 0.1% increments																																							
IEQ Offset	P2	±5% in 0.1% increments																																							
Display Options	P3	<table border="1" style="width: 100%; border-collapse: collapse;"> <thead> <tr> <th>Item</th> <th>Main Display</th> <th>Minor Display</th> </tr> </thead> <tbody> <tr><td>1</td><td>IEQ</td><td>Empty</td></tr> <tr><td>2</td><td>IEQ</td><td>Temperature</td></tr> <tr><td>3</td><td>Temperature</td><td>IEQ</td></tr> <tr><td>4</td><td>Temperature</td><td>Empty</td></tr> <tr><td>5</td><td>%RH</td><td>Temperature</td></tr> <tr><td>6</td><td>Temperature</td><td>%RH</td></tr> <tr><td>7</td><td>%RH</td><td>IEQ</td></tr> <tr><td>8</td><td>IEQ</td><td>%RH</td></tr> <tr><td>9</td><td>%RH</td><td>Empty</td></tr> <tr> <td colspan="3" style="text-align: center;">The Following Items Rotate Through the Main & Minor Display</td> </tr> <tr><td>10</td><td colspan="2">%RH, Temperature</td></tr> <tr><td>11</td><td colspan="2">%RH, IEQ, Temperature</td></tr> </tbody> </table>	Item	Main Display	Minor Display	1	IEQ	Empty	2	IEQ	Temperature	3	Temperature	IEQ	4	Temperature	Empty	5	%RH	Temperature	6	Temperature	%RH	7	%RH	IEQ	8	IEQ	%RH	9	%RH	Empty	The Following Items Rotate Through the Main & Minor Display			10	%RH, Temperature		11	%RH, IEQ, Temperature	
		Item	Main Display	Minor Display																																					
		1	IEQ	Empty																																					
		2	IEQ	Temperature																																					
		3	Temperature	IEQ																																					
		4	Temperature	Empty																																					
		5	%RH	Temperature																																					
		6	Temperature	%RH																																					
		7	%RH	IEQ																																					
		8	IEQ	%RH																																					
		9	%RH	Empty																																					
The Following Items Rotate Through the Main & Minor Display																																									
10	%RH, Temperature																																								
11	%RH, IEQ, Temperature																																								

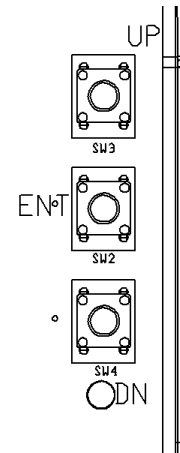
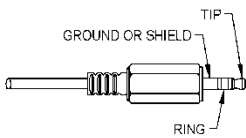

Figure 10:
Setup Buttons

Specifications subject to change without notice.

Optional Communications Jack Wiring



C35 Wiring	
	Wire Color
Ground	Black
Tip	White
Ring	Red

Note: Male Jack shown for clarity
C35 Communications Jack

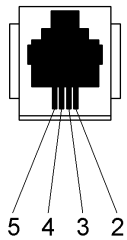

C11 Wiring	
Comm Jack Pin	Wire Color
1	Not Connected
2	Black
3	Red
4	Yellow
5	White
6	Not Connected

C11 Communications Jack

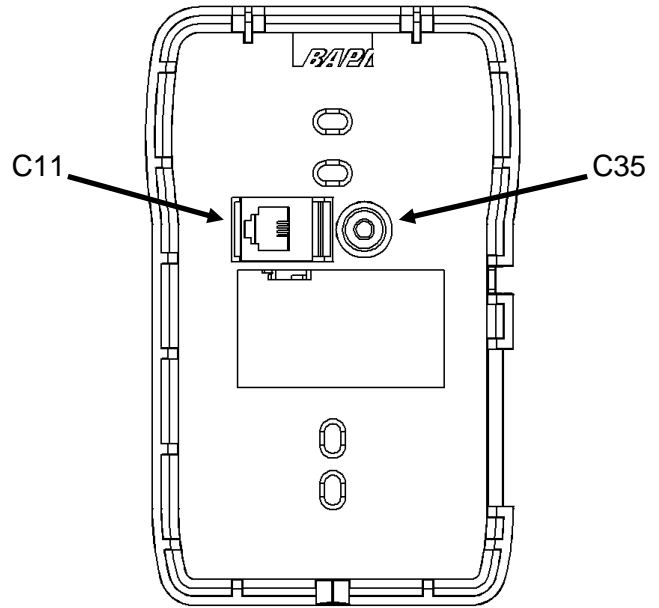

Figure 5: Communications Jacks

User Operation

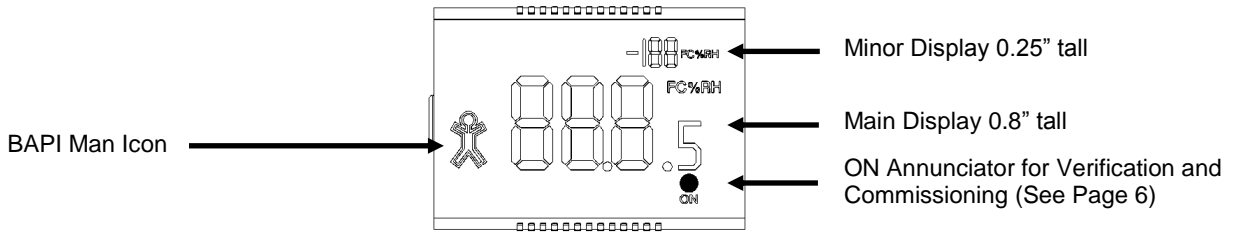

Figure 11: Optional Display

The display indicates air temperature in degrees Fahrenheit or Celsius, relative humidity in %RH, temperature setpoint in degrees Fahrenheit or Celsius and override using the BAPI Man icon. % VOC contamination is shown without units.

Temperature Setpoint Slide-Pot: Moving the slide pot enough to change the setpoint by one degree will display the setpoint on the main LCD display if equipped with display.



Override Button: When the override button is pressed on display units, the BAPI Man icon will display. A dry resistance of less than 15 ohms appears from the override output (OVR) to the Ground terminal (GND). Latching the Icon to show that the system is in override requires that a dry digital output on your controller be used to connect terminal EXT to ground.

Output Selection

The IEQ and humidity outputs may be configured for 0 to 5 VDC, 0 to 10 VDC or 2 to 10 VDC outputs. These are specified at time of order and programmed at the factory, they are not field adjustable. See the product part number label for settings.

Specifications subject to change without notice.

Sensor Start-up

At each power up, the sensor enters the start-up period for 15 minutes. The main display will show the current temperature and the minor display will show 123 for the first 15 seconds. The IEQ output and display will follow the timing shown in figure 12. Start-up time for the humidity output is 30 seconds, while the outputs for temperature and temperature setpoint are available immediately.

During the start-up period an optional verification/commissioning test, described below, may be performed. This test is not mandatory, it is necessary only for building commissioning or if verification of IEQ output is required.

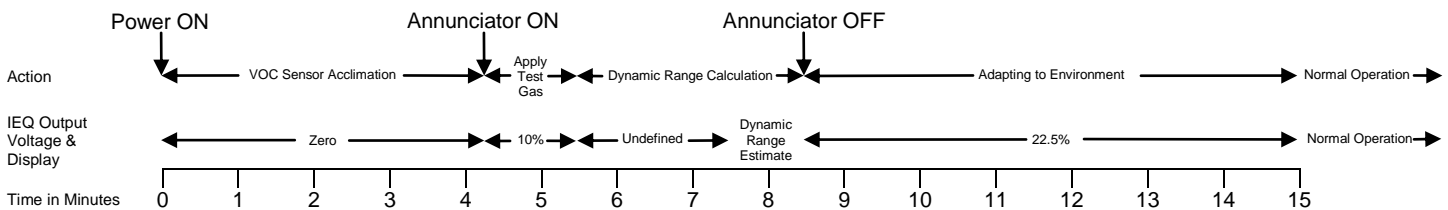

Figure 12: Sensor Start-up Timeline

Optional Sensor Performance Verification and Commissioning

The Indoor Environmental Quality [IEQ] monitor contains an adaptive, self adjusting, Volatile Organic Compound (VOC) sensor that provides a CO₂ equivalent control signal output. When incorporated into a control strategy based on ASHRAE's Demand Control Ventilation algorithm, the IEQ sensor can provide improved indoor environment quality.

The fundamental performance criterion of the VOC sensor is its dynamic sensing range. The VOC sensor requires a minimum dynamic range of 30% for proper operation. During BAPI's verification/commissioning test, the dynamic range is tested and displayed.

BAPI recommends installing the sensor and powering it for at least 48 hours before the first verification test is performed. BAPI further recommends ventilating the space such that the sensor reads 37.5% contaminant or less (750 ppm CO₂ equivalent) before any verification test is performed. Wait at least one hour before repeating the test.

1. Start Automatic Verification/Commissioning Test

- A. Remove sensor power for at least one minute and reapply. The IEQ sensor will set the IEQ output to zero volts and display units will show zero percent contaminants. (Power ON in figure 12)
- B. Wait four minutes fifteen seconds.
- C. The IEQ sensor will illuminate an annunciator (**ON** icon for display units and a red LED for duct mounted units) as well as set the IEQ output voltage to 10% of full scale (0.5 VDC for 0 to 5 VDC, 1.0 VDC for 0 to 10 VDC or 2.8 VDC for 2 to 10 VDC outputs).
- D. The visual indication and the 10% output voltage confirms that the IEQ sensor is in its verification/commissioning test. (Apply Test Gas period in figure 12)

2. Apply Verification Stimulus

- A. Apply the stimulus gas during the first minute after the sensor illuminates the annunciator (See *Stimulus Preparation and Application*).
- B. Read and record the IEQ output voltage or LCD display approximately 2 to 4 minutes following the stimulus gas application to determine the dynamic range measurement. (Dynamic Range Estimate period in figure 12)
- C. When the dynamic range estimate period is complete the annunciator illuminated in step 1C will be extinguished.

3. Termination of Verification Mode

- A. For the last 7 minutes of the start-up period the sensor adapts to its ambient environment, the IEQ sensor will maintain its output at 22.5% (450 ppm CO₂ equivalent).
- B. At 15 minutes the IEQ sensor will terminate the start-up period and begin normal operation.
- C. The IEQ output will now report the VOCs present as CO₂ equivalents.

4. Result Analysis and Recommendations

- A. The interpretation of the output in step 2B is a linear representation of the actual measured dynamic range of the sensor. An output value of 30% full scale represents 30% dynamic range. An output of 70%, 80%, or 90% full scale equates to a sensor dynamic range of equivalent values.
- B. The IEQ algorithm requires a 30% dynamic range for proper operation. Sensors reporting 30% or less dynamic range should be considered for replacement. (see Figure 14)
- C. The VOC sensor board is field replaceable, contact your BAPI representative for details.

Specifications subject to change without notice.

Stimulus Preparation and Application

Customer supplied – 70% minimum Isopropyl Alcohol.

Place 50ml of the Isopropyl Alcohol into a 200ml glass bottle (2oz in an 8oz glass bottle) with stopper and allow to reach room temperature (65° to 80°F, 18° to 27°C), a minimum of 15 minutes.

1. Using a medical grade syringe, remove the stopper from the alcohol bottle, place the tip of the syringe at least half-way into the bottle and withdraw a 60 ml sample of the alcohol vapor. (no liquid)
2. Replace the stopper on the alcohol bottle.
3. Place the end of the syringe -
 - A. Over, or into the top ventilation slot of the IEQ monitor's housing for room versions.
 - B. Into a knockout opening or directly into the aspiration probe's top hole for duct mount versions.
4. Empty the syringe into the sensor using one continuous motion.

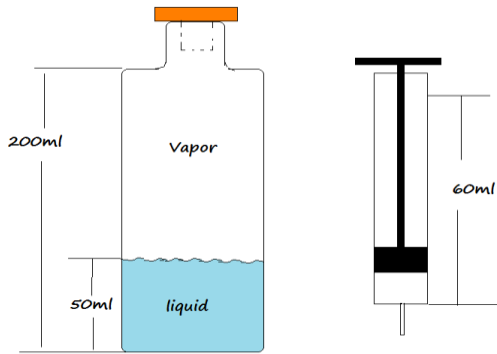

Figure 13: Alcohol Bottle and Syringe

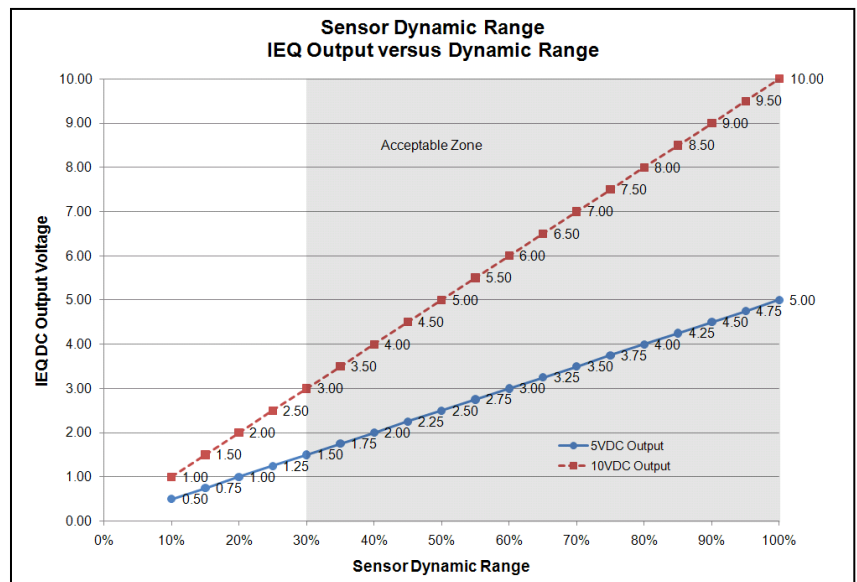

Figure 14: Acceptable Dynamic Range Output

Specifications subject to change without notice.



Diagnostics

Possible Problems:

General troubleshooting

Possible Solutions:

- Determine that the input is set up correctly in the controller's and building automation software.
- Check wiring at the sensor and controller for proper connections.
- Check for corrosion at either the controller or the sensor. Clean off the corrosion, re-strip the interconnecting wire and reapply the connection. In extreme cases, replace the controller, interconnecting wire and/or sensor.
- Label the terminals that the interconnecting wires are connected to at the sensor end and the controller end. Disconnect the interconnecting wires from the controller and the sensor. With the interconnecting wires separated at both ends measure the resistance from wire-to-wire with a multimeter. The meter should read greater than 10 Meg-ohms, open or OL depending on the meter you have. Short the interconnecting wires together at one end. Go to the other end and measure the resistance from wire-to-wire with a multimeter. The meter should read less than 10 ohms (22 gauge or larger, 250 feet or less). If either test fails, replace the wire.
- Check power supply/controller voltage supply
- Disconnect sensor and check power wires for proper voltage (see specifications below)

Incorrect IEQ

- Wait 15 minutes after a power interruption.
- Check all software parameters
- Determine if the sensor is exposed to an external environment different from the room (conduit draft)

Incorrect Humidity

- Check all software parameters
- If available, check the sensor against a calibrated instrument such as a hygrometer
- Determine if the sensor is exposed to an external environment different from the room (conduit draft)

Incorrect Temperature

- Determine that the temperature sensor's wires are connected to the correct controller input terminals and are not loose.
- Check the wires at the sensor and controller for proper connections.
- Measure the physical temperature at the temperature sensor's location using an accurate temperature standard.

Output to Controller

Disconnect the temperature sensor's wire (Terminals TP+ & TP-) and measure the temperature sensor's resistance across the sensor output pins with an ohmmeter. Put the ohmmeter's black lead on Terminal TP- and the red lead on Terminal TP+. Compare the temperature sensor's resistance to the appropriate temperature sensor table on the BAPI web site (See below). If the measured resistance is different from the temperature table by more than 5% call BAPI technical support. Don't forget to reconnect the wires.

How to Find Temperature Sensor Resistance

Find BAPI's web site at www.bapivac.com; click on the button labeled SENSORS on the left of the screen and then click on the sensor type you have.

- Make sure that the sensor leads are not touching one another.
- Determine if the sensor is exposed to an external environment different from the room (conduit or wall cavity draft)

Specifications subject to change without notice.