

### Overview

BAPI's Dew Point Sensor is an easy and economical way to measure the dew point temperature. The unit is available with an optional LCD display, temperature setpoint slider and an occupant override pushbutton.

The large format display allows you to easily read Dew Point Temperature and Dry Bulb Temperature. The display alternates between these values and is field adjustable between °F or °C. One or both of the displayed values may be easily turned on or off by an HVAC technician.

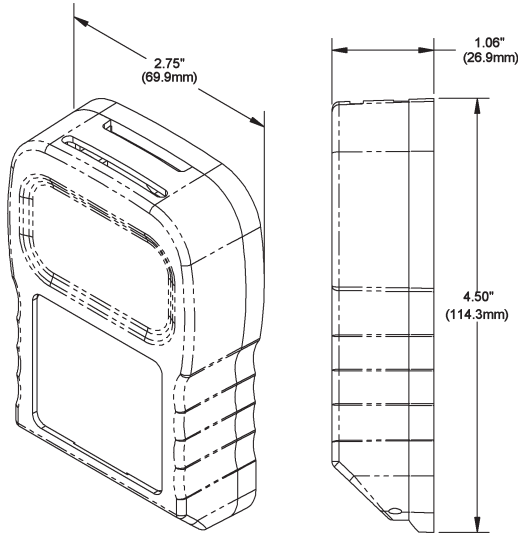

Figure 1: BAPI-Stat 2 Dew Point

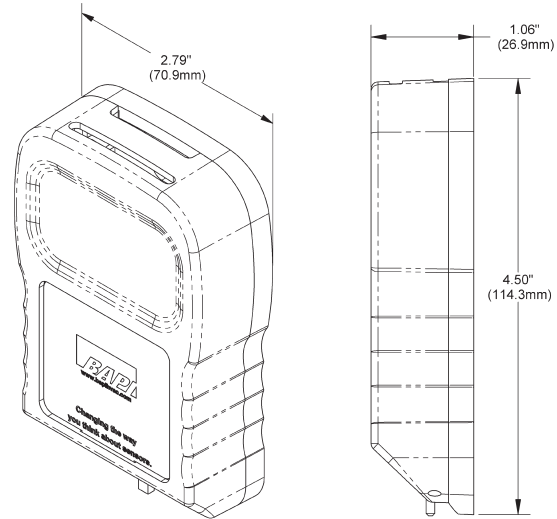

Figure 2: BAPI-Stat 2 Dew Point with override and Setpoint

### Specifications

**Power:** 15 to 35 VDC @ 4 mA max  
No AC power

**Sensing Element:**  
Humidity – Capacitive Polymer,  
±1.8% RH Accuracy

**Temperature Sensor**  
Thermistor, RTD or Semiconductor

**Mounting:** 2"x4" J-Box or drywall mount  
(screws provided)

**Dew Point Temperature Range:**  
-4°F to 122°F (-20°C to 50°C)

**Response Time:** Less Than 60 Seconds

**Operating Environment:**  
32 - 122°F (0 - 50°C)  
0 - 95%RH non-condensing

**LCD Display:** 3.5 digit numeric  
(Dew Pt & Dry Bulb Temp)

**Measurement Offsets (field adjustable)**  
±5° (F or C) in 0.1° or 0.5° increments – DB  
±5 RH in 0.1% or 0.5% increments – RH

**Analog Output (0-5VDC or 0-10VDC, 1KΩ impedance)**  
Dew Point Temperature ..... -4 to 122°F (-20 to 50°C)

**Weight:** .25lb, (.11kg)

**Material:** ABS Plastic, Material Rated UL94V-0

**Certifications:** CE, RoHS

**Warranty:** Two years from manufacture date

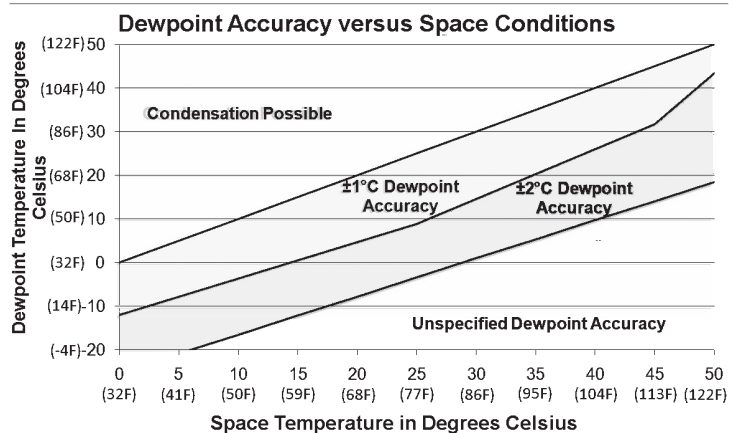

### Mounting

Mounting hardware is provided for both junction box and drywall installation (junction box installation shown).

#### Junction Box

1. Pull the wire through the wall and out of the junction box, leaving about six inches free.
2. Pull the wire through the hole in the base plate.
3. Secure the plate to the box using the #6-32 x 1/2 inch mounting screws provided.
4. Terminate the unit according to the guidelines in the **Termination** section.
5. Attach Cover by latching it to the top of the base, rotating the cover down and snapping it into place.
6. Secure the cover by backing out the lock-down screws using a 1/16" Allen wrench until they are flush with the bottom of the cover.

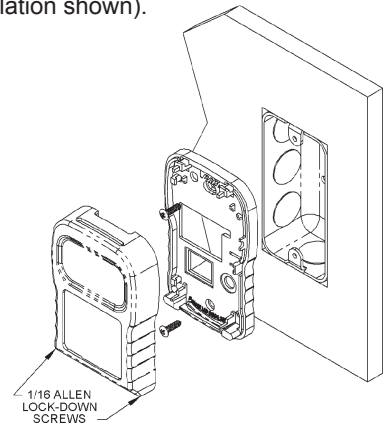

**Fig 3:** Mounting to a Junction Box

#### Drywall Mounting

1. Place the base plate against the wall where you want to mount the sensor.
2. Using a pencil mark out the two mounting holes and the area where the wires will come through the wall.
3. Drill two 3/16" holes in the center of each marked mounting hole. Insert a drywall anchor into each hole.
4. Drill one 1/2" hole in the middle of the marked wiring area.
5. Pull the wire through the wall and out of the 1/2" hole, leaving about six inches free.
6. Pull the wire through the hole in the base plate.
7. Secure the base to the drywall anchors using the #6 x 1 inch mounting screws provided.
8. Terminate the unit according to the guidelines in the **Termination** section.
9. Attach cover by latching it to the top of the base, rotating the cover down and snapping it into place.
10. Secure the cover by backing out the lock-down screws using a 1/16" Allen wrench until they are flush with the bottom of the cover.

**NOTE:** In any wall-mount application, the wall temperature and the temperature of the air within the wall cavity can cause erroneous readings. The mixing of room air and air from within the wall cavity can lead to condensation, erroneous readings and sensor failure. BAPI recommends sealing the conduit leading to the junction box, filling the junction box with fiberglass insulation or sealing the wall cavity.

### Terminations

BAPI recommends using twisted pair of at least 22AWG and sealant filled connectors for all wire connections. Larger gauge wire may be required for long runs. All wiring must comply with the National Electric Code (NEC) and local codes.

Do NOT run this device's wiring in the same conduit as AC power wiring of NEC class 1, NEC class 2, NEC class 3 or with wiring used to supply highly inductive loads such as motors, contactors and relays.

BAPI recommends against wiring the sensor with power applied as accidental arcing may damage the product and void the warranty.

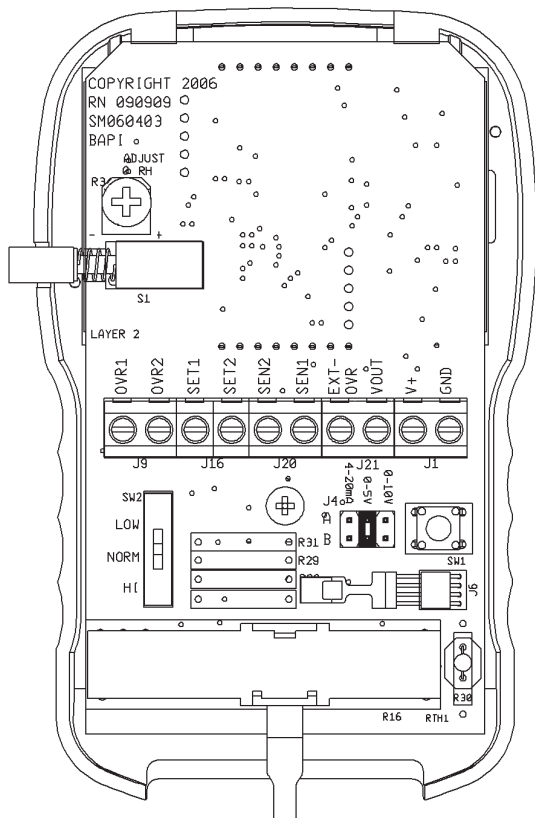

**Fig 4:** Circuit Board

**Note1:** The termination screws should be turned fully Counter Clockwise (CCW) to open the jaws fully. Then insert the field wire and turn the screws Clock Wise (CW) to pinch the wire fully closed. If the jaws are left partially open, the inserted wire may be on bottom of, instead of inside, the jaws causing a poor connection.

#### 0 to 5 VDC or 0 to 10 VDC Termination

Terminal	Function
OVR1 & OVR2	Override Output (Dry Contact Switch). OVR2 is internally connected to SET2 & SEN2.
SET1 & SET2	Setpoint output. SET2 is internally connected to OVR2 & SEN2.
SEN1 & SEN2	Sensor Output (Resistive Output). SEN2 is internally connected to OVR2 & SET2. (Semiconductor SEN1=+, SEN2=-)
EXT-OVR	Allows remote control of the LCD indicator for occupancy, and is activated by logic LOW or power supply ground at this terminal.
VOUT	Dew Point Signal [to analog input of controller]
V+	Power, 15 to 35VDC No AC power
GND	To controller power supply ground [GND or Common]

**NOTE:** OVR2, SEN2, and SET2 are connected together internally.

### Optional Test Balance Switch

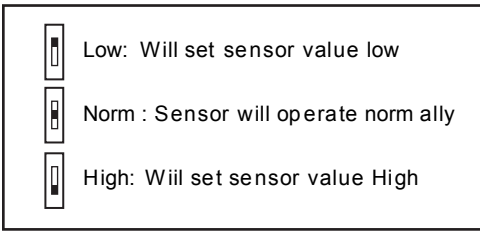

Sensor Type	Low Temp	High Temp
1000 Ω RTD	1.02K Ω (41.2°F)	1.15K Ω (101.5°F)
3000 Ω Thermistor	7.87K Ω (39.8°F)	1.50K Ω (106.8°F)
10K-2 Thermistor	30.1K Ω (34.9°F)	4.75K Ω (109.1°F)
10K-3 Thermistor	26.7K Ω (35.9°F)	5.11K Ω (108.4°F)
10K-3(11K) Thermistor	7.32K Ω (43.7°F)	3.65K Ω (105.2°F)

### Optional Technician Adjustments

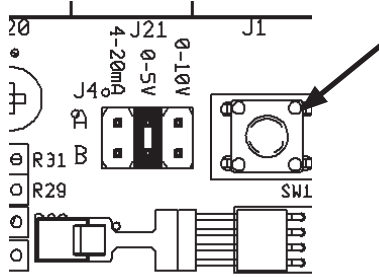

The optional technician adjustment procedure allows temperature and humidity offsets, °F or °C display units or display information to be changed at any time. When the unit is powered up, pressing the tact switch at SW1 will enter the user calibration adjustment mode (See Figure 5). When pressed, the LCD will show page zero, P0. The page numbers auto-scroll to P5 and then the unit returns to the normal run mode. Pressing SW1 when any page number is displayed will show the value that is associated with that page. The variable will auto-scroll and will show all the allowed values for the selected page. Pressing SW1 when the variable value you need is shown will record that value and return to showing page numbers.

**Figure 5:** Calibration Switch

Parameter	Page Designator	Adjustment
Temperature Offset	P0	±5° in 0.1° increments
Humidity Offset***	P1	±5% in 0.1% increments or R34 When R34 is selected, humidity offset is set by turning potentiometer R34 situated just above the override switch. See Figure 6.
Display Units	P2	°F or °C
Display DP to Temp Toggle Time	P3	3 to 11 seconds
Display Resolution	P4	0 = 0.5
		1 = 0.1
Display Section	P5	0 = Temperature, Dew Point and Temperature Setpoint when active*
		1 = Temperature and Temperature Setpoint when active*
		2 = Dew Point and Temperature Setpoint when active*
		3 = Temperature, Dew Point and Temperature Setpoint**
		4 = Temperature and Temperature Setpoint**
		5 = Dew Point and Temperature Setpoint**
		6 = Temperature Setpoint
		7 = Temperature and Dew Point**
		8 = Temperature
		9 = Dew Point
10 = Temperature, Dew Point and %RH		

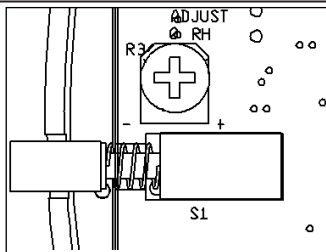

**Figure 6:** R34

\* When active means when moving the setpoint slider.

\*\* Display toggles through selections.

\*\*\* If dew point temperature needs adjustment place display into option 10. Adjust humidity offset for closest reading to your standard.

### Optional Communications Jack Wiring

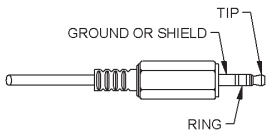

C35 Wiring	
Wire Color	
Ground	Black
Tip	White
Ring	Red

**Note:** Male Jack shown for clarity

**Figure 7:** C35 Communications Jack

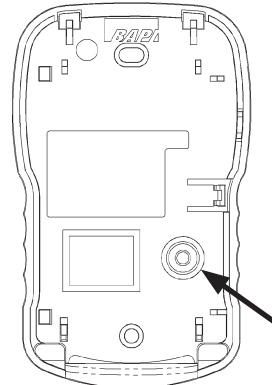

3.5mm Front

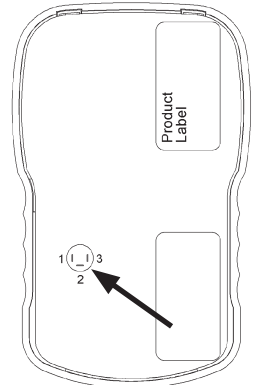

3.5mm Back

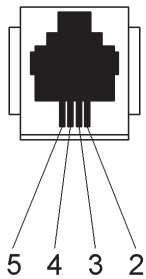

C11 Wiring	
Comm Jack Pin	Wire Color
1	Not Connected
2	Black
3	Red
4	Yellow
5	White or Green
6	Not Connected

**Figure 8:** C11 Communications Jack

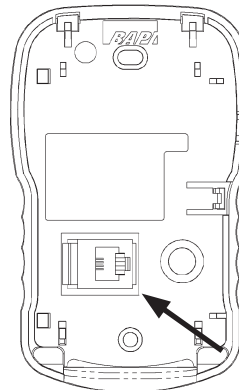

C11L Front

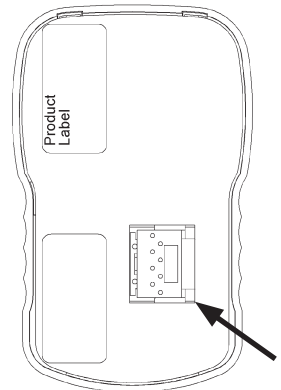

C11L Back

### Dew Point Output Selection

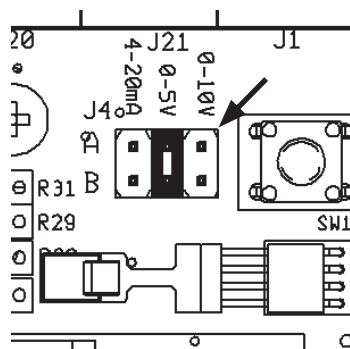

Moving the jumper on connector J4 will change the dew point output from 0 to 5VDC or 0-10VDC. Figure 9 shows the jumper in the 0 to 5VDC, position. 4-20mA position is inactive.

**Figure 9:** Output Jumpers

**User Operation**

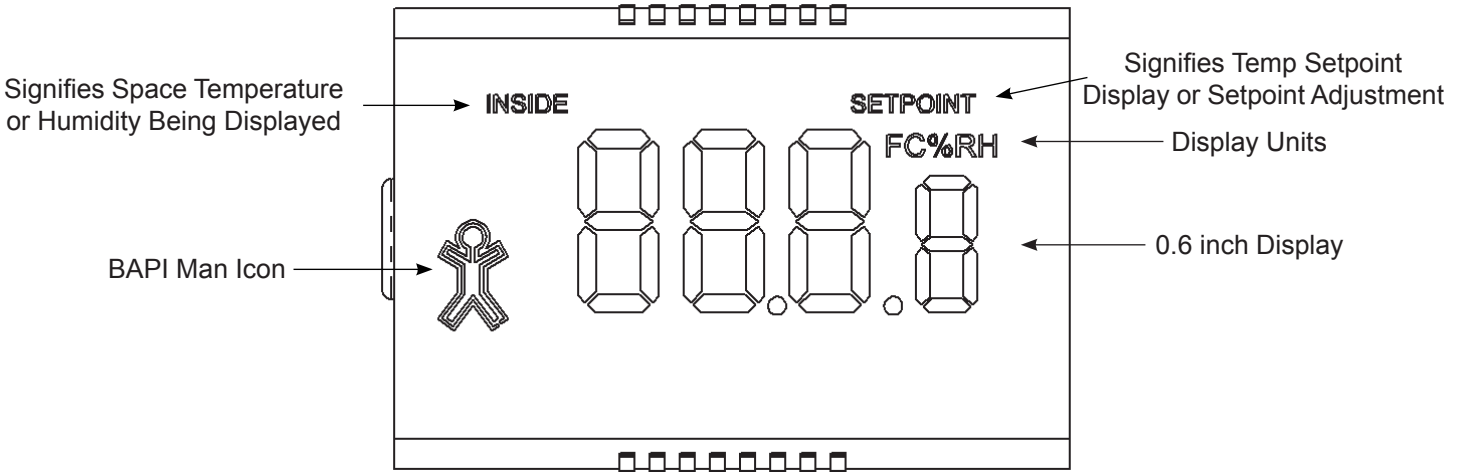

**Figure 10: Optional Dew Point Display**

The display indicates dry bulb temperature in degrees Fahrenheit or Celsius, dew point in degrees Fahrenheit or Celsius, relative humidity in %RH, temperature setpoint in degrees Fahrenheit or Celsius. Temperatures and relative humidity can be displayed in a rotating manner, see the Optional Technicians Adjustments section. The BAPI Man icon indicates that the override button has been pushed.

**Dry Bulb Temperature:** When dry bulb temperature is displayed the INSIDE icon as well as the appropriate units icon are illuminated.

**Dew Point Temperature:** When dew point temperature is displayed the letters dP are displayed for 2 seconds just before the dew point temperature is displayed. Then the dew point temperature is displayed with the appropriate units icon illuminated, the INSIDE icon is off.

**Relative Humidity:** When relative humidity is displayed the INSIDE icon as well as %RH are illuminated.

**Setpoint Slide-Pot:** When the temperature setpoint is active (see technician adjustments), moving the slide pot enough to change the setpoint by one degree will display the setpoint on display units. **Override Button:** When pressed, the

override icon  will display on display units. A dry resistance of less than 15 ohms appears across the override output (OVR1 to OVR2). Latching the Icon to show that the system is in override requires that a digital output on your controller be used to connect terminal EXT-OVR to power supply ground.

**Diagnostics**Possible Problems:

General troubleshooting

Possible Solutions:

- Determine that the input is set up correctly in the controller's and building automation software.
- Check wiring at the sensor and controller for proper connections.
- Check for corrosion at either the controller or the sensor. Clean off the corrosion, re-strip the interconnecting wire and reapply the connection. In extreme cases, replace the controller, interconnecting wire and/or sensor.
- Label the terminals that the interconnecting wires are connected to at the sensor end and the controller end. Disconnect the interconnecting wires from the controller and the sensor. With the interconnecting wires separated at both ends measure the resistance from wire-to-wire with a multimeter. The meter should read greater than 10 Meg-ohms, open or OL depending on the meter you have. Short the interconnecting wires together at one end. Go to the other end and measure the resistance from wire-to-wire with a multimeter. The meter should read less than 10 ohms (22 gauge or larger, 250 feet or less). If either test fails, replace the wire.

Incorrect Dew Point

- Check power supply/controller voltage supply
- Disconnect sensor and check power wires for proper voltage (see specifications below) Check all software parameters
- If available, check the sensor against a calibrated instrument such as a hygrometer
- Determine if the sensor is exposed to an external environment different from the room (conduit draft)

Incorrect Temperature

- Determine that the temperature sensor's wires are connected to the correct controller input terminals and are not loose.
- Check the wires at the sensor and controller for proper connections.
- Measure the physical temperature at the temperature sensor's location using an accurate temperature standard.

**Output to Controller**

Disconnect the temperature sensor's wire (Terminals SEN1 & SEN2) and measure the temperature sensor's resistance across the sensor output pins with an ohmmeter. Put the ohmmeter's black lead on Terminal SEN2 and the red lead on Terminal SEN1. Compare the temperature sensor's resistance to the appropriate temperature sensor table on the BAPI web site (See below). If the measured resistance is different from the temperature table by more than 5% call BAPI technical support. Don't forget to reconnect the wires.

**How to Find Temperature Sensor Resistance**

Find BAPI's web site at [www.bapihvac.com](http://www.bapihvac.com); click on the button labeled SENSORS on the left of the screen and then click on the sensor type you have.

- Make sure that the sensor leads are not touching one another.
- Determine if the sensor is exposed to an external environment different from the room (conduit draft)