

Overview

The BAPI Wireless Thermobuffer Temperature Transmitter measures the temperature of a refrigerator or freezer and transmits the data through 418MHz RF to a receiver. The transmitter is mounted in a BAPI-Box™ style enclosure and has a usable range of 100 feet. The added mass of the Thermo Buffer, filled with a water-glycol solution, alcohol or mineral oil, approximates the temperature at the center of a small box on the freezer's shelf.

The transmit rate is approximately once every 10 seconds with an estimated battery life of 5 to 8 years using two high-capacity 3.6V lithium batteries. Each transmitter has a unique address with built in error detection. Each variable sent by the transmitter is picked up by the receiver and converted by a BAPI Analog Output Module to a voltage, current or resistance signal which is sent to the controller. A point manager may be used to collect the temperature data for large systems.

Product Identification

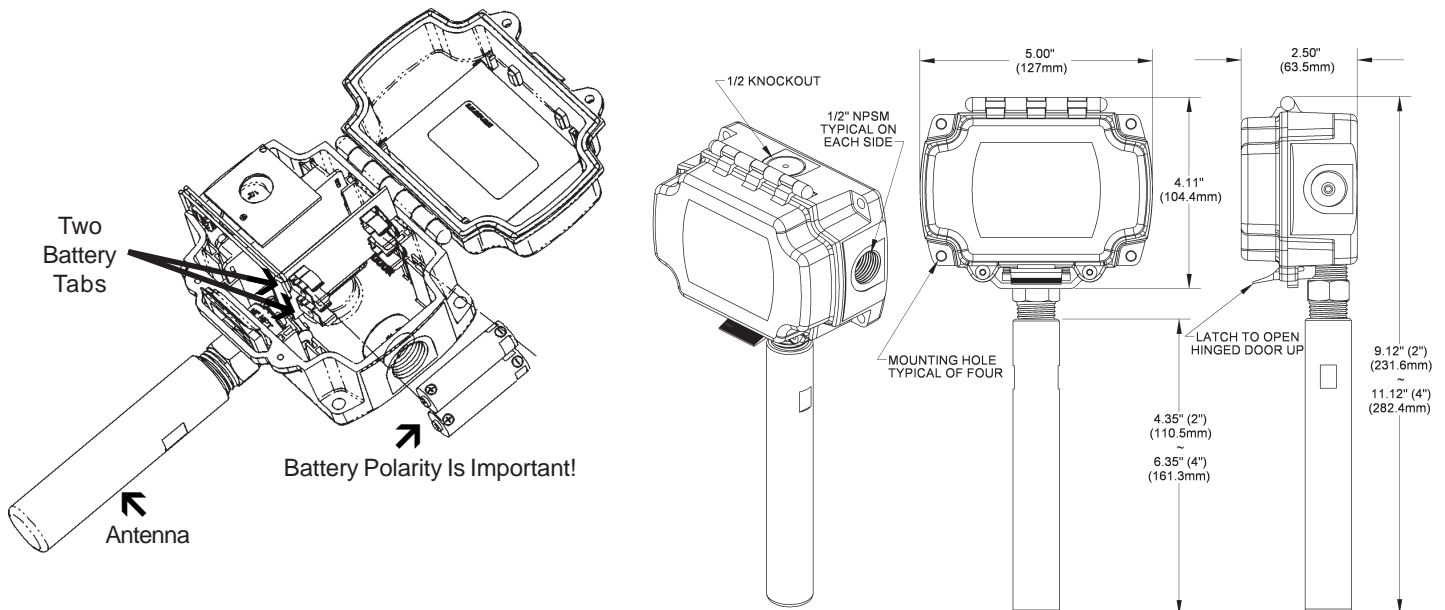

Fig 1: Wireless Thermobuffer Temperature Sensors

Analog Output Module Training

Note 1: It is best to perform this procedure before mounting the transmitters.

1. Pick a transmitter and a temperature analog output module you want to train to recognize one another. Connect the output module to the receiver.
2. Apply power to the receiver and output module.
3. The power LED on the Receiver should light and remain lit. The powered analog output module's LED should flash and go out. (The flash is very quick.)
4. Open the cover of the transmitter and remove battery tabs or install the batteries, observe polarity (Figure 1). The transmitter LED, next to the Transmitter Training Button in Figure 4, should flash approximately once every 10 seconds. (The flash is very quick.)
5. Press and hold the plastic service button on the top of the Output Module, at the same time press for one second and release the training button on the transmitter module. When the LED on the analog output module lights, release its button (The LED will go out when you release the button). The output module will now report the environmental conditions from the transmitter trained to it. The output module's LED will quickly flash whenever it receives an update from the transmitter.
6. Close the cover and mount the transmitter at the desired location. If needed, remove the batteries to do so. The units will remain trained to one another through power failures and battery replacement.

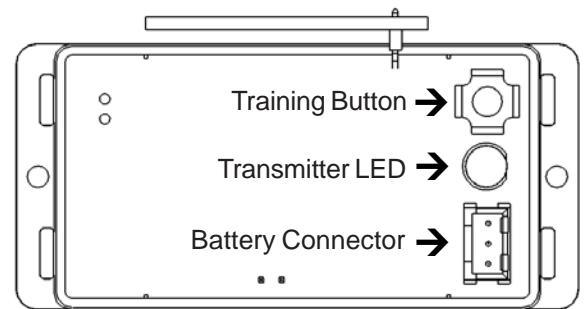

Fig 2: Transmitter Module

Specifications subject to change without notice.



Wireless Thermobuffer Temperature Transmitter 418 MHz

Installation & Operating Instructions

20414_ins_wireless_thermobuffer

rev.

Assembly

First train the modules as described on the previous page.

There are two sizes of Thermo Buffers, a 2-inch and 4-inch. The recommended amounts of Glycol, alcohol or mineral oil are as follows,

The two inch buffer requires 30 CC

The four inch buffer requires 40 CC.

Use a glycol deemed food safe such as Cool Flow FG.

Be sure that the glycol solution is mixed for a temperature below the lowest expected freezer temperature.

Wrap the threads on the sensor with Teflon tape. Use food safe silicone if desired to make a good liquid tight seal. **Do not use pipe dope as it is not food safe.**

After filling the thermo buffer with the appropriate amount of glycol thread the buffer onto the probe by first threading it onto the 1/2" NPT threads until it is snug. It should not leak. Use a 15/16" (24mm) wrench to tighten.

Do not use a channel locks or pliers as it may leave marks in the material that may allow for bacteria growth.

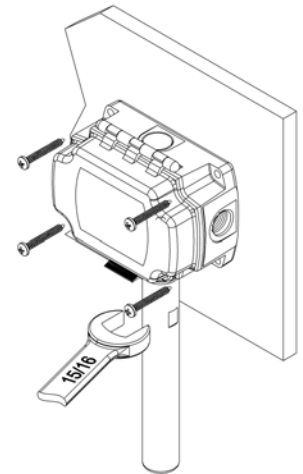

Fig 3: Assembly

Mounting

Mount the unit to its mounting surface with four #10 screws through the holes in the mounting feet. #10 sheet metal screws require 5/32" (4mm) pilot holes. For concrete or cinder block, drill four 5/32" (4mm) holes, 1-3/4 inch (45mm) deep. Make sure that all screws are started in their holes before tightening. Tighten evenly. Only squeeze the foam gasket to about 1/2 of its original thickness.

2/14/11

BAPI recommends **BA/Screw-Pan-1.5x10-SS-100** and **BA/Anchor-10-100** for drywall and **BA/ScrewHexConcrete1.5x10SS100** for concrete

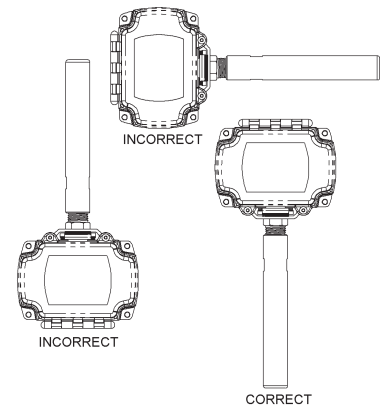

Diagnostics

Possible Problems:

Temperature reading is incorrect

Possible Solutions:

- Check wire from output modules to controller for proper connections and polarities.
- Check to see if the controller's software is configured properly.
- Check transmitter to see if its LED flashes about every 10 seconds. If not replacthe batteries.
- Check power to the receiver and output module.
- Check output modules LED, if it is blinking fast
Check the associated transmitter as described above
Retrain the modules

Temperature reading is coming out the wrong output module

-Retrain the modules.

Mounting

Supply Power: Two 3.6V Lithium batteries.

5 to 8 year battery life at 10 second transmit rate

Inputs: Replaceable Temperature/Relative Humidity Sensor

Accuracy: ±0.3 °C

Transmitted Range: -40° to 85°C

FCC Approval: FCC ID# T4F06811RH

Antenna: Built inside the enclosure

Environmental Operation Range:

Temp: -22°F to 158°F (-30°C to 70°C)

Humidity: 0% to 100% RH, Non-condensing

Material: ABS Plastic

Material Rating: UL94 V-0

Radio Frequency: 418 MHz

Transmitter Interval: ~10 seconds

Specifications subject to change without notice.