



Wireless Outdoor Temperature/Humidity Transmitter 418MHz

Installation and Operating Instructions

19704_ins_wireless_out_temp_hum_xmtr

Rev 12/22/2010

Overview

The BAPI Wireless Combination Transmitter measures the outdoor temperature and humidity and transmits the data through 418MHz RF to a receiver. The transmitter is mounted in a BAPI-Box™ style enclosure and has an open-air range of 100 feet.

The transmit rate is approximately once every 10 seconds with an estimated battery life of 5 to 8 years using two high-capacity 3.6V lithium batteries. Each transmitter has a unique address with built in error detection. Each variable sent by the transmitter is picked up by the receiver and converted by a BAPI Analog Output Module to a voltage, current or resistance signal which is sent to the controller. A point manager may be used to collect the temperature and humidity data for large systems.

Product Identification

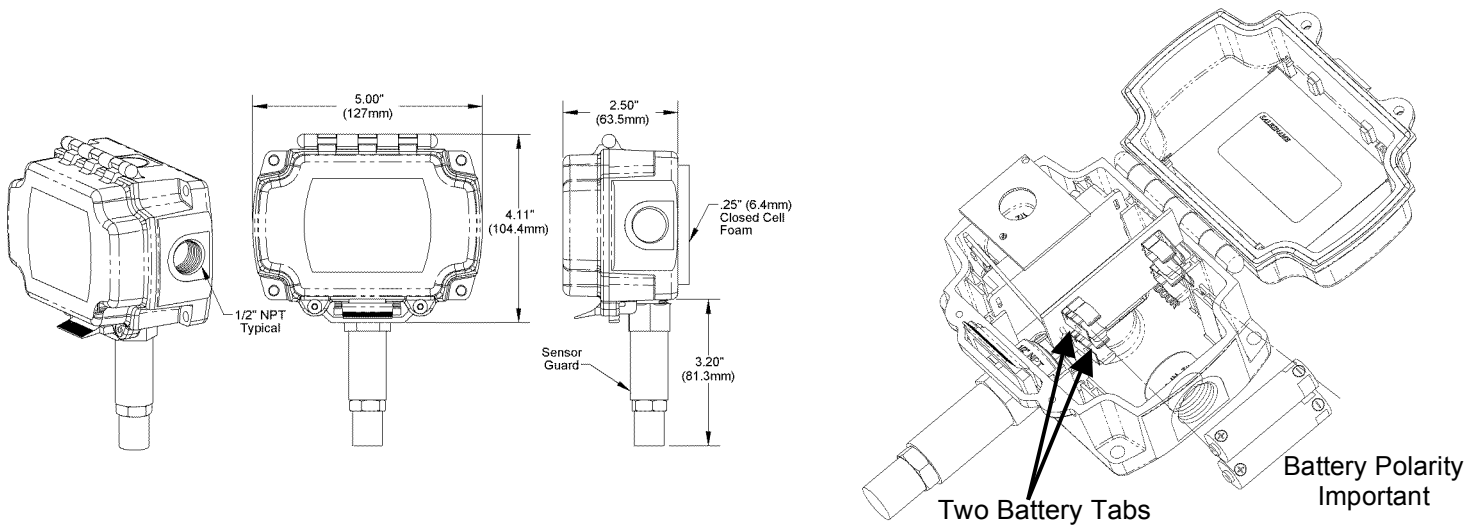

Figure 1: Wireless Outdoor Temperature & Humidity Transmitter

Tools and Materials

Screwdriver, Drill

Mounting

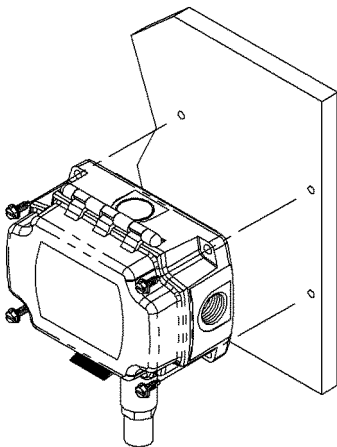

Figure 2: Outdoor Mounting

First train the modules as shown on the next page.

Mount the unit to its mounting surface with four #10 screws through the holes in the mounting feet. #10 sheet metal screws require 5/32" (4mm) pilot holes. For concrete or cinder block, drill four 5/32" (4mm) holes, 1-3/4 inch (45mm) deep. Make sure that all screws are started in their holes before tightening. Tighten evenly. If unit has a foam gasket, only squeeze the gasket to about 1/2 of its original thickness.

BAPI recommends **BA/Screw-Pan-1.5x10-SS-100** and **BA/Anchor-10-100** for drywall and **BA/Screw-Hex-Concrete-1.5x10-SS-100** for concrete.

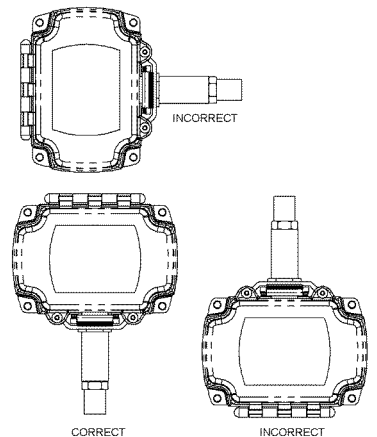

Figure 3: Sensor Orientation

Specifications subject to change without notice.



Wireless Outdoor Temperature/Humidity Transmitter 418MHz

Installation and Operating Instructions

19704_ins_wireless_out_temp_hum_xmtr

Rev 12/22/2010

Analog Output Module Training

It is best to perform this procedure before mounting the transmitters.

1. Apply power to the receiver and output modules.
2. The power LED on the Receiver should light and remain lit. The powered analog output module's LED should flash and go out. (The flash is very quick.)
3. Open the cover of the transmitter and remove the battery tabs or install the batteries, observe polarity (see Fig 1). The transmitter LED, next to the Transmitter Training Button in Figure 4, should flash approximately once every 10 seconds. (The flash is very quick.)
4. Pick a transmitter and a temperature analog output module you want to train to recognize one another. Press and hold the plastic service button on the top of the Output Module, at the same time press for one second and release the button on the transmitter. When the LED on the output module lights, release its button (The LED will go out when you release the button). The output module will now report the environmental conditions from the transmitter trained to it. The output module's LED will quickly flash whenever it receives an update from the transmitter. Repeat for the humidity analog output module.
5. Close the cover and mount the transmitter at the desired location. If needed, remove the batteries to do so. The units will remain trained to one another through power failures and battery replacement.

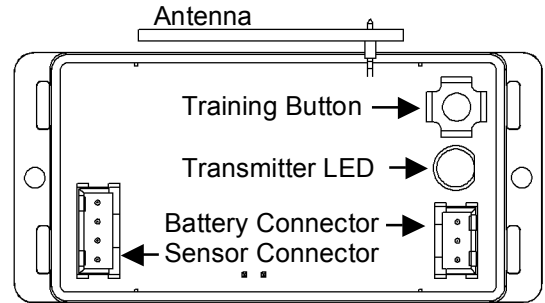

Figure 4: Transmitter Module

Dianostics

Possible Problems:

Temperature or Humidity reading is incorrect

Possible Solutions:

- Check wire from output modules to controller for proper connections and polarities.
- Check to see if the controller's software is configured properly.
- Check transmitter to see if its LED flashes about every 10 seconds. If not replace the batteries.
- Check power to the receiver and output module.
- Check output modules LED, if it is blinking fast
Check the associated transmitter as described above
Retrain the modules

Temperature or Humidity reading is coming out the wrong output module

- Retrain the modules.

Specifications

Supply Power: Two 3.6V Lithium batteries.

5 to 8 year battery life at 10 second transmit rate

Inputs: Replaceable Temperature/Relative Humidity Sensor

Accuracy: $\pm 0.3^{\circ}\text{C}$ / $\pm 2\%$ RH

Transmitted Range: -40° to 85°C / 0-100% RH

FCC Approval: FCC ID# T4F06811RH

Antenna: Built inside the enclosure

Environmental Operation Range:

Temp: 0° to 60°C

Humidity: 5% to 95% RH non-condensing

Material: ABS Plastic

Material Rating: UL94 V-0

Radio Frequency: 418 MHz or 433 MHz

Transmitter Interval: ~ 10 seconds

Specifications subject to change without notice.