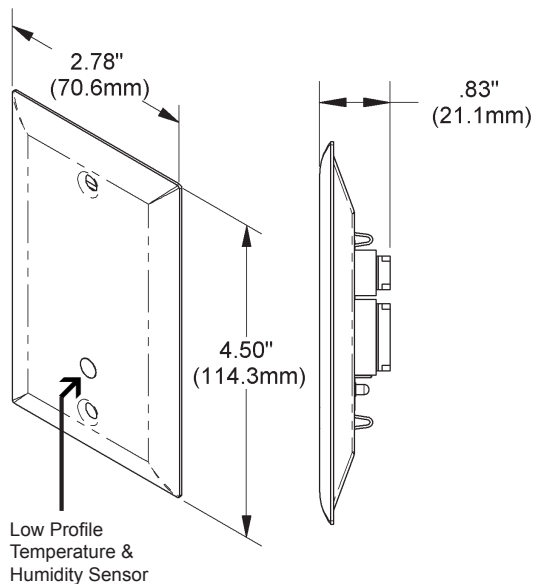
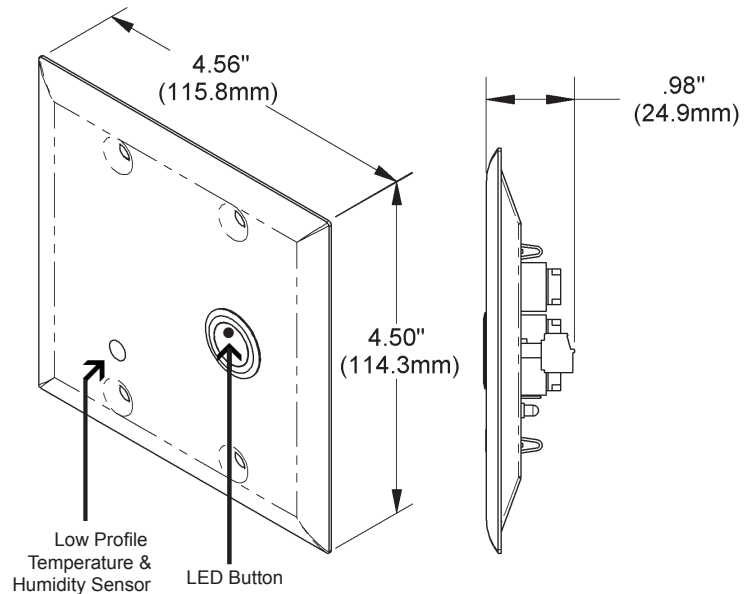

Overview

The BAPI Washdown Wall Plate Unit (**BA/SPV**) measures the room temperature and humidity and transmits the data to an analog output module through wired RS-485 communications. Multiple BA/SPV Plates can reside on a single RS485 communication trunk. Each transmitter is mounted on a single or dual gang stainless steel wall plate. A dual gang plate provides space for an optional switch and direct temperature sensor which are direct wired to the controller.

The data transmit rate between the Washdown Wall Plate Unit and the analog output modules is approximately once every 10 seconds. Each Washdown Wall Plate Unit has a unique address with built in error detection. Each variable sent by the Washdown Wall Plate Unit is picked up and converted by a BAPI Analog Output Module to a voltage, current or resistance signal which is wired to the controller. This plate can be washed down with a damp cloth. Directed water at any pressure is not recommended.

Product Identification**Fig 1: BA/SPV Single Gang Temperature & Humidity Transmitter****Fig 2: BA/SPV-02 Dual Gang Temp/Humidity Transmitter with Button****Mounting and Cleaning**

The Washdown Wall Plate Unit can be mounted over a J-Box or directly to a wall. Mounting hardware is provided for both junction box and drywall installation.

Junction Box:

1. Pull the wire through the wall and out of the junction box, leaving about six inches free.
2. Terminate the unit according to the guidelines in **Termination** section.
3. Secure the plate to the box using the #6-32 x 1/2 inch mounting screw provided.
4. If liquid water is used to clean, you must caulk the screw heads using a butyl rubber sealant to prevent against water infiltration.

Drywall Mounting:

1. Place the plate against the wall where you want to mount the sensor.
2. Using a pencil mark out the two mounting holes.
3. Drill a 3/16" diameter hole in the center of each marked mounting hole. Insert a drywall anchor into each hole.
4. Cut hole between the two mounting holes that clears the apparatus mounted on the plate.
5. Pull the wire through the wall hole cut in step 4, leaving about six inches free.
6. Terminate the unit according to the guidelines in **Termination** section.
7. Secure the plate to the drywall anchors using the #6 x 1 inch mounting screws provided.
8. If liquid water is used to clean, you must caulk the screw heads using a butyl rubber sealant to prevent against water infiltration.

Cleaning:

1. The plate may be wiped using a clean damp cloth using clean water and hand washing soap.
2. Rinse the sensor with clean fresh water with a damp cloth and towel dry or air dry.
3. If hosing down is unavoidable, then protect the sensor from direct water spray using a BAPI-Guard. Do not use chemicals in the water spray.

- Caution:
1. Bleach, peroxide or ammonia will ruin the sensor.
 2. Directed water such as a hose, pressure washer or spray bottle should not be used.

Specifications subject to change without notice.

J-Loop Termination Technique

Incorporating a “J-Loop” (also known as a drip loop) into all terminations adds an additional layer of protection against moisture and oxidation by directing moisture away from the connection. The idea is to place the wire junction as high as possible and form a “J” with the lead wires. The bottom of this “J” should be below the junction point. Any moisture that collects on the lead wires is pulled downward by gravity to the bottom of this loop and away from the connection.

Termination

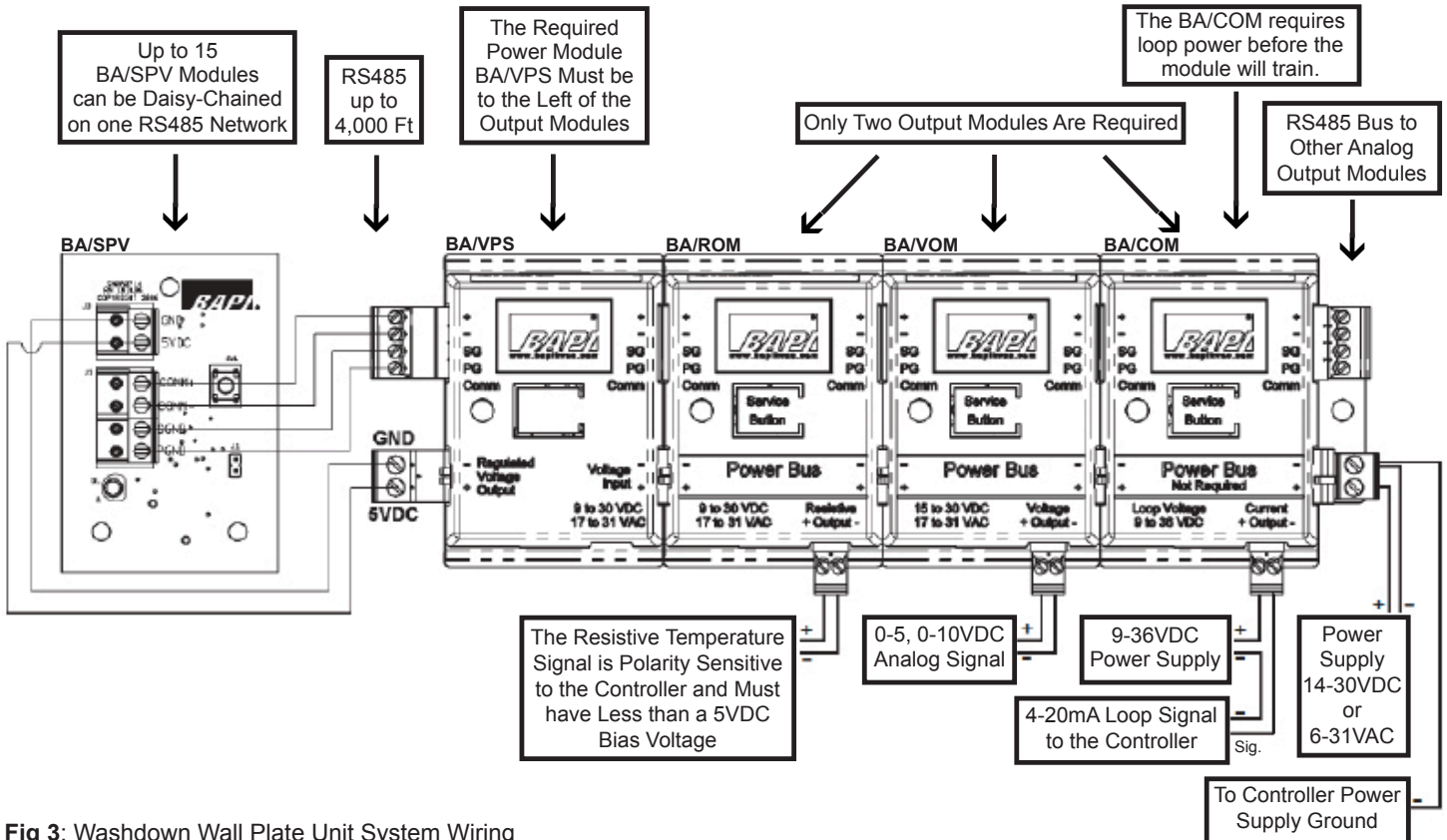

Fig 3: Washdown Wall Plate Unit System Wiring

- Note 1:** Each BA/SPV Wall Sensor requires two (2) output modules. One (1) is for Temperature, one (1) for Humidity and one (1) BA/VPS Power Supply.
- Note 2:** Wire the Washdown Wall Plate Unit to the Washdown Wall Plate Power Supply and analog modules as shown in fig 3 above.
- Note 3:** Up to 15 (fifteen) Washdown Wall Plate Units can be connected to the network, all wired in parallel with the first.
- Note 4:** Up to one hundred twenty seven (127) analog output modules may be connected to the Washdown Wall Plate Power Supply, connector to connector or with RS485 cable.
- Note 5:** The total aggregate length of the RS485 cable is 4,000Ft (305 meters).
- Note 6:** If any RS485 cable segment for the output modules is longer than 100Ft (30.5 meters) each group of analog output modules should have its own power supply.
- Note 7:** The BA/COM requires loop power before the module will train.

Specifications subject to change without notice.

Override & Direct Sensor Termination

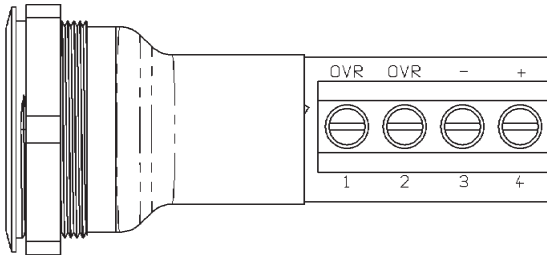

Fig 4: Push-button (N.O.) and LED override (water resistant)

Note 8: OVR, (Numbers 1 & 2) are N.O. Contacts and LED, (Numbers 3 and 4) are 5VDC or 24V AC/DC per the order.

Note 9: The LED, Direct Sensor and override button are wired directly to the controller and Do Not communicate via the RS485 to the BA/VPS or output modules.

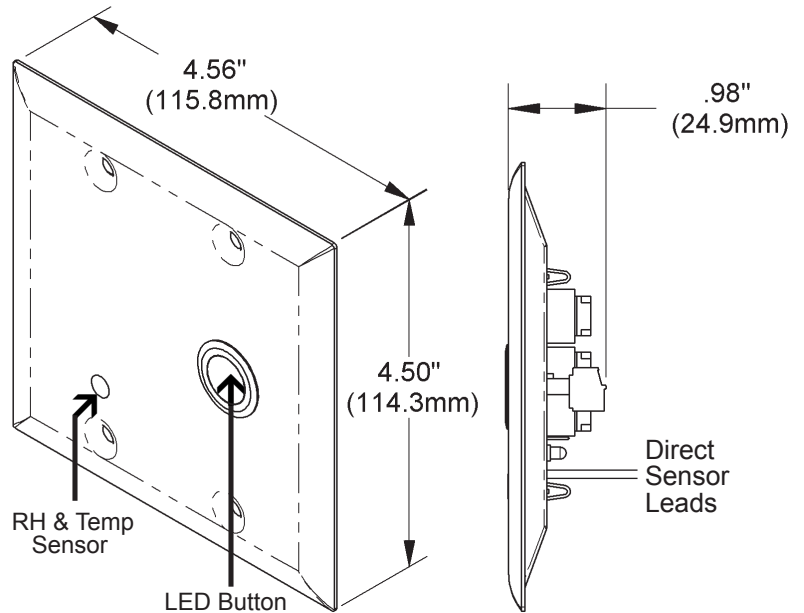

Fig 5: Dual Gang Plate with Button, LED, RH and Temperature Sensor.

Analog Output Module Training

Note: It may be easier to perform this procedure in the shop before mounting the units at the job site.

1. Connect the Washdown Wall Plate Power Supply to the Washdown Wall Plate Unit and plug in the output modules.
2. Apply power to the Washdown Wall Power Supply and output modules.
3. The power LED on the Washdown Wall Plate Power Supply should light and remain lit. The powered analog output module's LED should flash and go out. (The flash is very quick.)
5. The LED on the Washdown Wall Plate Unit should flash once approximately every 10 seconds. (The flash is very quick.)
6. Pick a Washdown Wall Plate Unit and an analog output module you want to train to recognize one another. Press and hold the plastic service button on the top of the Output Module, at the same time press for one second and release the training button on the Washdown Wall Plate Unit. When the LED on the output module lights, release its button (The LED will go out when you release the button). The output module will now report the environmental conditions from the Washdown Wall Plate Unit trained to it. The output module's LED will quickly flash whenever it receives an update from the Washdown Wall Plate Unit. Temperature and Humidity Analog Output Modules are trained separately.
7. Mount the Washdown Wall Plate Unit at the desired location. The units will remain trained to one another through power failures.

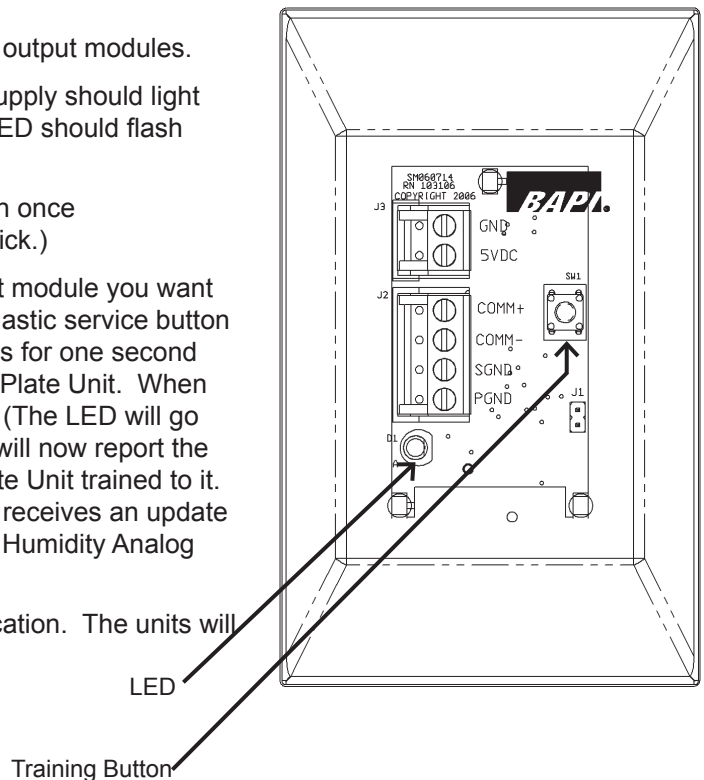

Fig 6: Back of Washdown Wall Plate Unit

Specifications subject to change without notice.



BA/SPV Washdown Wall Plate Unit

Installation & Operating Instructions

17786_ins_spv

rev.02/23/11

Diagnosics

Possible Problems:

Temperature or Humidity is reading its low limit

Temperature or Humidity reading is coming out of the wrong output module

Temperature or Humidity is reading incorrectly

Possible Solutions:

Check wire from output modules to controller for proper connections and polarities.

Check to see if the controller's software is configured properly.

Check Washdown Wall PlateUnit to see if its LED flashes about every 10 seconds.

Check power to the output module.

Check output modules LED, if it is blinking fast Check the associated Washdown Wall Plate Unit as described above. Retrain the modules

Retrain the modules.

Check wire from output modules to controller for proper connections and polarities.

Check to see if the controller's software is configured properly.

Check to see if the correct output module is connected to the right controller.

Specifications

Power:

5VDC from BA/VPS Washdown Wall Plate Power Supply
0.5mA max DC with 1 Washdown Wall Plate Unit attached
10mA max DC with 15 Washdown Wall Plate Unit attached

Environmental:

Temperature: -30°C to 70°C (-22°F to 158°F)

Humidity: 0% to 100% RH, non-condensing

Humidity Measurement:

Sensor Type: Capacitive Polymer

Accuracy: ±2% RH

Temperature Measurement:

Sensor Type: Band Gap, Proportional to Absolute Temperature

Accuracy: 0.9°F, 23 to 120°F (0.5°C, 0 to 49°C)

RS-485 Cable Distance:

4,000 Ft (305 meters) with shielded, twisted pair cable

(Belden 9842, Belden 8132, or equivalent)

15 BA/SPV Wall Units maximum per BA/VPS

Rating:

NEMA3R, IP64

Required Accessories: (Power Supply & Output Module)

BA/VPS Power Supply Module

BA/VOM Voltage Output Module

BA/COM Current Output Module

BA/ROM Thermistor Output Module

Options:

Push button water resistant

LED lamp, 5v or 24v AC/DC per order

Cleaning:

Wash with damp cloth (see Cleaning)

Do not use directed pressure washing

Specifications subject to change without notice.