



# Wireless Room Temperature/Humidity Transmitter

## Installation and Operating Instructions

17616\_ins\_wireless\_temp\_hum\_xmtr

Rev 12//22/2010

### Overview

The BAPI Wireless Combination Transmitter measures the room temperature and humidity and transmits the data through 418MHz RF or 433MHz to a receiver. The transmitter is mounted in a BAPI-Stat 2 style enclosure and has an open-air range of 100 feet.

The transmit rate is approximately once every 10 seconds with an estimated battery life of 5 to 8 years using two high-capacity 3.6V lithium batteries. Each transmitter has a unique address with built in error detection. Each variable sent by the transmitter is picked up by the receiver and converted by a BAPI Analog Output Module to a voltage, current or resistance signal which is sent to the controller. The unit can be set up to trigger an alarm on the controller when the batteries need replacing.

### Product Identification

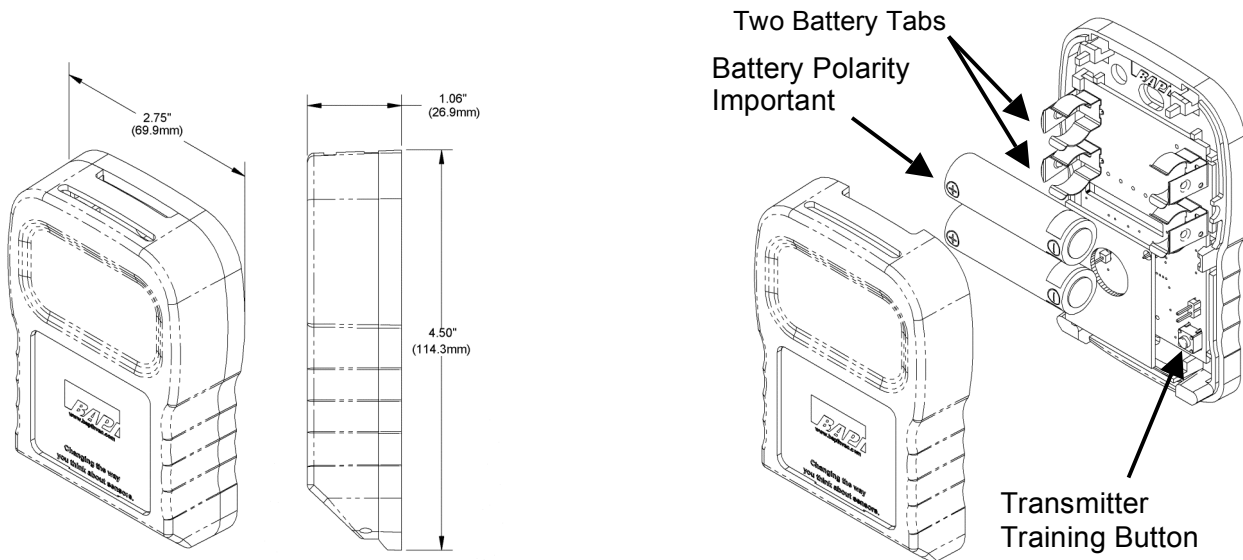
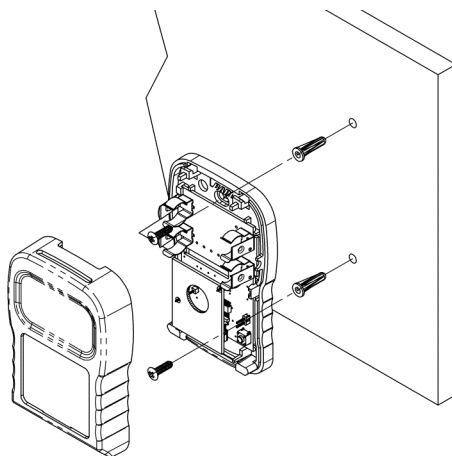

Figure 1: Wireless Temperature & Humidity Transmitter

### Tools and Materials

#2 Philips Screwdriver, 1/8" Screwdriver with 1/16" Allen wrench (BA/116W), Drill

### Mounting



#### Drywall Mounting

1. Place the base plate against the wall where you want to mount the sensor.
2. Using a pencil mark out the two mounting holes.
3. Drill two 3/16" holes in the center of each marked mounting hole. Insert a drywall anchor into each hole.
4. Secure the base to the drywall anchors using the #6 x 1 inch mounting screws provided.
5. Attach cover by latching it to the top of the base, rotating the cover down and snapping it into place.
6. Secure the cover by backing out the lock-down screws using a 1/16" Allen wrench until they are flush with the bottom of the cover.
7. Remove the battery tabs (see Figure 1) or install the batteries to start the sensor transmitting.

Figure 2: Drywall Mounting

Specifications subject to change without notice.



# Wireless Room Temperature/Humidity Transmitter

## Installation and Operating Instructions

17616\_ins\_wireless\_temp\_hum\_xmtr

Rev 12//22/2010

### Analog Output Module Training

1. Apply power to the receiver and output modules.
2. The power LED on the Receiver should light and remain lit. The powered analog output module's LED should flash and go out. (The flash is very quick.)
3. Remove the cover of the transmitter and remove the battery tabs or install the batteries, observe polarity. The small LED at the bottom right, next to the Transmitter Training Button in Figure 1, should flash approximately once every 10 seconds. (The flash is very quick.)
4. Pick a transmitter and an analog output module you want to train to recognize one another. Press and hold the plastic service button on the top of the Output Module, at the same time press for one second and release the button on the transmitter. When the LED on the output module lights, release its button (The LED will go out when you release the button). The output module will now report the environmental conditions from the transmitter trained to it. The output module's LED will quickly flash whenever it receives an update from the transmitter.
5. Mount the transmitter at the desired location. If needed, remove the batteries to do so. The units will remain trained to one another through power failures and battery replacement.
6. Replace the transmitter's cover and back out the security screws.

### Troubleshooting

#### Possible Problems:

Temperature or Humidity is reading its low limit

#### Possible Solutions:

- Check wire from output modules to controller for proper connections and polarities.
- Check to see if the controller's software is configured properly.
- Check transmitter to see if its LED flashes about every 10 seconds. If not replace the batteries.
- Check power to the receiver and output module.
- Check output modules LED, if it is blinking fast  
Check the associated transmitter as described above  
Retrain the modules

Temperature or Humidity reading is coming out the wrong output module

- Retrain the modules.

Temperature or Humidity is reading incorrectly

- Check wire from output modules to controller for proper connections and polarities.
- Check to see if the controller's software is configured properly.
- Check to see if the correct output module is connected to the right controller.

### Specifications

**Supply Power:** Two 3.6V Lithium batteries, 5 to 8 year battery life at 10 second transmit rate

**Inputs:** Replaceable Temperature/Relative Humidity Sensor

**Accuracy:**  $\pm 0.3^{\circ}\text{C}$  /  $\pm 2\%$  RH

**Transmitted Range:**  $-40^{\circ}$  to  $85^{\circ}\text{C}$  / 0-100% RH

**FCC Approval:** FCC ID# T4F16963N16964 (418MHz only)

**Antenna:** Built inside the enclosure

**Environmental Operation Range:**

Temp:  $0^{\circ}$  to  $60^{\circ}\text{C}$

Humidity: 5% to 95% RH non-condensing

**Material:** ABS Plastic

**Material Rating:** UL94 V-0

**Radio Frequency:** 418 MHz or 433 MHz

**Transmitter Interval:**  $\sim 10$  seconds

Specifications subject to change without notice.