

Product Identification

The VC350 is half wave rectified. The VAC neutral input and the VDC GND output are common.

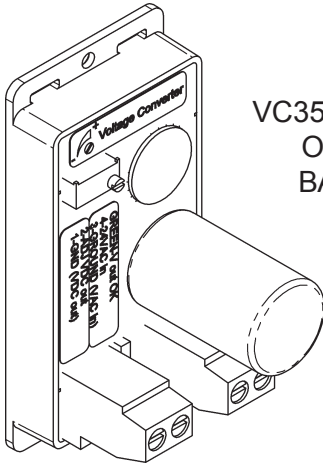

Figure 1:
VC350 with Adjustable
Output Voltage
BA/VC350-ADJ

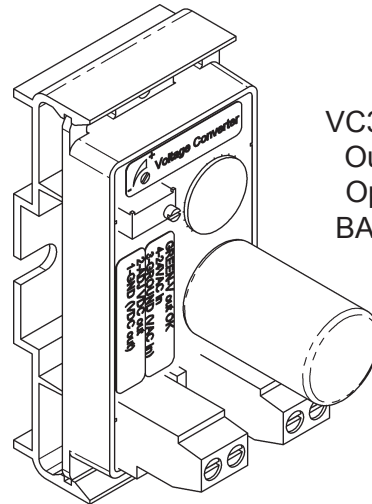

Figure 2:
VC350 with Adjustable
Output Voltage with
Optional Snaptrack
BA/VC350-ADJ-TRK

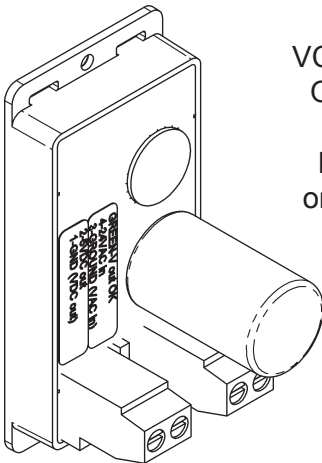

Figure 3:
VC350 with Fixed
Output Voltage
BA/VC350-5,
BA/VC350-12
or BA/VC350-15

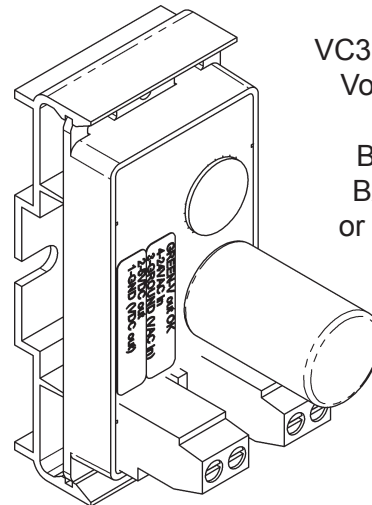

Figure 4:
VC350 with Fixed Output
Voltage with Optional
Snaptrack
BA/VC350-5-TRK,
BA/VC350-12-TRK
or BA/VC350-15-TRK

Mounting

Mounting without snaptrack: Peel the backing from the tape on the back of the unit and attach to the surface where you need to mount the unit.

Mounting with snaptrack: Remove the VC350 from the snaptrack. Screw the snaptrack to the surface where you need to mount the unit. Replace the VC350 in the snaptrack.



This unit should be mounted at or within 2 feet of the control panel. DO NOT mount near or directly behind your room sensor.



The VC350 is intended to convert the AC power provided at the panel to DC. Tests show that the fluctuating and inaccurate peripheral device signal levels are possible when AC power wiring is present in the same conduit as the signal lines.

Specifications subject to change without notice.

Termination

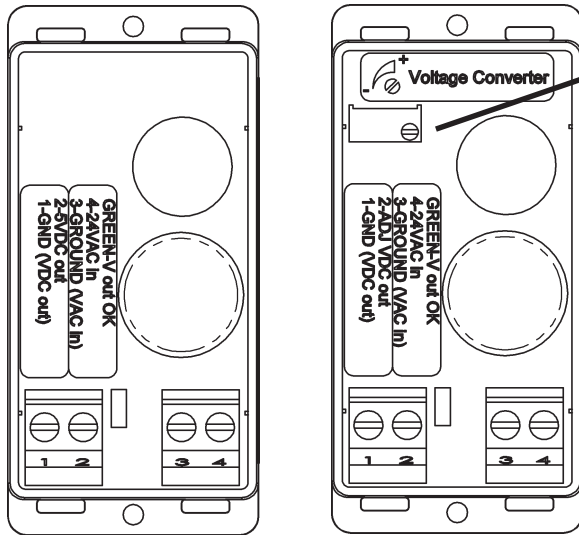

VDC adjustment potentiometer

Terminal Number	Function
1	Ground (VDC out)
2	DC Output Voltage
3	Ground (VAC in)
4	24 VAC Input

NOTE: -ADJ models are set to 24VDC output at the factory. If 24VDC is too high for your circuit adjust the output to a lower voltage before you connect the BA/VC350 to the load. Be sure to check and adjust the BA/VC350's output voltage, if necessary, when the load is applied.

NOTE: The connectors use a rising block screw terminal to hold the wires. It is possible for the block to be in a partially up position allowing the wire to be inserted under the block. Be sure that the connector screws are turned fully counterclockwise before inserting the wire. Lightly tug on each wire after tightening to verify proper termination.

Figure 5:
VC350 Terminations

Specifications

Input Voltage: 18 to 30 VAC, 24 VDC

Input Current Max: 760 mA AC (18.25 VA), 400 mA DC

Output: 5 to 26 VDC at 350 mA

Specifications subject to change without notice.