

592 Theory of Operation

The 592 sensor is a two terminal integrated-circuit temperature sensor. The 592 provides an output current directly proportional to absolute temperature. When the temperature of the 592 sensor changes one-Kelvin (one-degree Celsius), then the current through the 592 changes by 1uAmp. 77° Fahrenheit (25° Celsius) is 298.2 Kelvins and the output current from the 592 sensor is 298.2uAmp. Initial accuracy of the 592 temperature sensor is $\pm 8.1^\circ$ Fahrenheit ($\pm 4.5^\circ$ Celsius) at 77° Fahrenheit (25° Celsius).

Since most meters that field technicians use cannot accurately measure currents this low, BAPI recommends that a 10K Ω 0.1% resistor be placed between the sensor output and ground. The 10K Ω resistor changes the current into a voltage that varies 0.01 volts per one degree Celsius temperature change; the voltage at 77°F is 2.982 VDC. Resistors with other tolerances can be used, but you will have greater temperature uncertainty, see the 10K Ω uncertainty table;

BAPI provides two styles of humidity probe with a 592 sensor, one with and one without the 10,000 ohm 0.1% resistor. The one with the resistor has three wires - red, black and white. The one without the resistor has two wires - red and black.

10K Ω uncertainty Table	
Tolerance	Temperature uncertainty
0.1%	$\pm 8.64^\circ\text{F}$
1%	$\pm 13.47^\circ\text{F}$
5%	$\pm 34.93^\circ\text{F}$

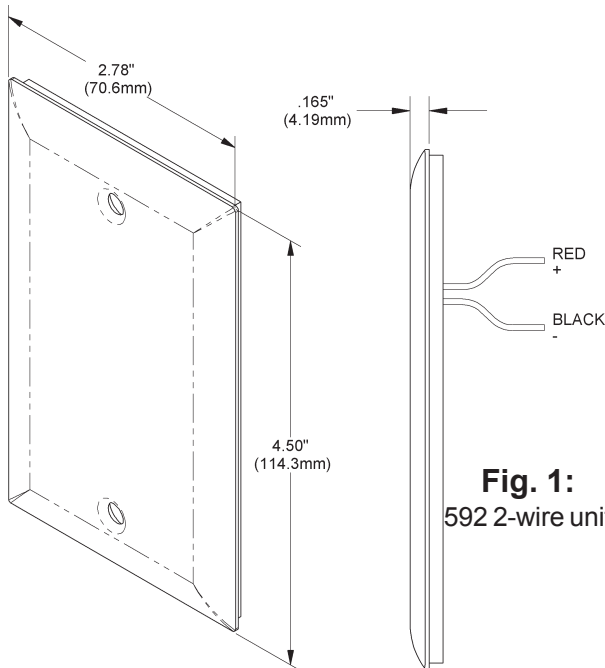

Fig. 1:
592 2-wire unit

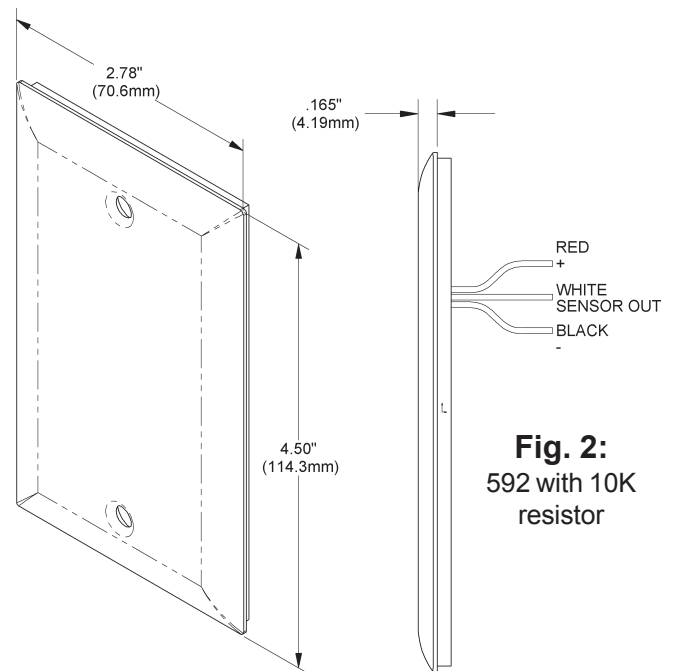

Fig. 2:
592 with 10K resistor

Termination

Table 2: 592 2-Wire Sensors

1. Install a 10K Ω 0.1% resistor from the controller's analog input to the controller's ground or common.
2. If you are using a separate DC power supply, connect the power supply's negative terminal to the controller's ground or common..
3. Connect the 592 sensor's black wire to the controller's analog input.
4. Connect the 592 sensor's red wire to 5 to 30 VDC.

Table 3: 592 3-Wire Sensors

1. All BAPI BA/592-10K, 3-wire, sensors have a built in 10K Ω 0.1% resistor.
2. If you are using a separate DC power supply, connect the power supply's negative terminal to the controller's ground or common..
3. Connect the 592 sensor's black wire to the controller's ground or common.
4. Connect the 592 sensor's white wire to the controller's analog input.
5. Connect the 592 sensor's red wire to 5 to 30 VDC.

Specifications subject to change without notice.



Temperature Measurement Offsetting

All BA/592 sensors will have the following information provided on a label:

Therm Reading _____

The actual temperature reading according to a thermometer that is certified traceable to recognized standards by the National Institute of Standards and Technology (NIST).

Sensor Reading _____

The temperature reading according to the AD592 sensor. The output is dropped across a 10KΩ 0.1%, read in mV and converted to a Fahrenheit temperature.

Offset _____

The difference between the Thermometer Reading and the Sensor Reading

To correct the Sensor Reading, simply add the offset value to the sensor reading so that it equals the thermometer reading.

e.g. Therm Reading = 74.6, Sensor Reading = 73.0, Offset = +1.6
Correction: Add (+1.6) °F to the sensor for an accurate reading: 73 + 1.6 = 74.6°F

e.g. Therm Reading = 75.4, Sensor Reading = 77.2, Offset = -1.8
Correction: Add (-1.6) °F to the sensor for an accurate reading: 77.2 + (-1.8) = 75.4°F

Troubleshooting

GENERAL TROUBLESHOOTING AND POSSIBLE SOLUTIONS

- Determine that the input is set up correctly in the controller's and building automation software.
- Check wiring for proper termination
- Check for corrosion at either the controller or the sensor. Clean off the corrosion, re-strip the interconnecting wire and reapply the connection. In extreme cases, replace the controller, interconnecting wire and/or sensor.
- Label the terminals that the interconnecting wires are connected to at the sensor end and the controller end. Disconnect the interconnecting wires from the controller and the sensor. With the interconnecting wires separated at both ends measure the resistance from wire-to-wire with a multimeter. The meter should read greater than 10 Meg-ohms, open or OL depending on the meter you have. Short the interconnecting wires together at one end. Go to the other end and measure the resistance from wire-to-wire with a multimeter. The meter should read less than 10 ohms (22 gauge or larger, 250 feet or less). If either test fails, replace the wire.

592 SENSOR TROUBLESHOOTING

Note: The BAPI crimp-on sealant filled connectors have a convenient hole opposite the wire opening to insert a meter probe for measurements.

- 1) Measure the sensible temperature at the sensors location using an accurate temperature standard.
- 2) Set your meter to the Volts setting.
- 3) Measure from the controller ground (black sensor lead) to the 592's power lead (red sensor lead) for +5 to +30 VDC.
- 4) Set your meter to the mV setting.
 - a) For two wire units place a 10KΩ resistor between the sensors black lead and the return wire to the controller. Measure and record the voltage across the resistor.
 - b) For three-wire units measure and record the voltage from the black lead to the white lead.
- 5) Using Table 4, if the sensor voltage is greater or less than 0.050VDC from the expected voltage measurement, call BAPI technical support.
- 6) If the sensor reads properly, verify that the controller is operating correctly.
- 7) If the sensor reads improperly, determine if the sensor is exposed to an external source different from the measured environment (conduit draft).

Temperature		592 Semiconductor	
°F	°C	Output Current uA	Output Voltage across 10KΩ
50	10	283.2	2.832
60	15.56	288.8	2.888
62	16.67	289.9	2.899
64	17.78	291	2.91
66	18.89	292.1	2.921
68	20	293.2	2.932
70	21.11	294.3	2.943
72	22.22	295.4	2.954
74	23.33	296.5	2.965
76	24.44	297.6	2.976
78	25.56	298.8	2.988
80	26.67	299.9	2.999
82	27.78	301	3.01
84	28.89	302.1	3.021
86	30	303.2	3.032
88	31.11	304.3	3.043
90	32.22	305.4	3.054
100	37.78	311	3.11

Specifications subject to change without notice.