

## Termination

BAPI recommends using twisted pair of at least 22AWG and sealant filled connectors for all wire connections. Larger gauge wire may be required for long runs. All wiring must comply with the National Electric Code (NEC) and local codes.

Do NOT run this device's wiring in the same conduit as AC power wiring of NEC class 1, NEC class 2, NEC class 3 or with wiring used to supply highly inductive loads such as motors, contactors and relays. BAPI's tests show that fluctuating and inaccurate signal levels are possible when AC power wiring is present in the same conduit as the signal lines. If you are experiencing any of these difficulties, please contact your BAPI representative

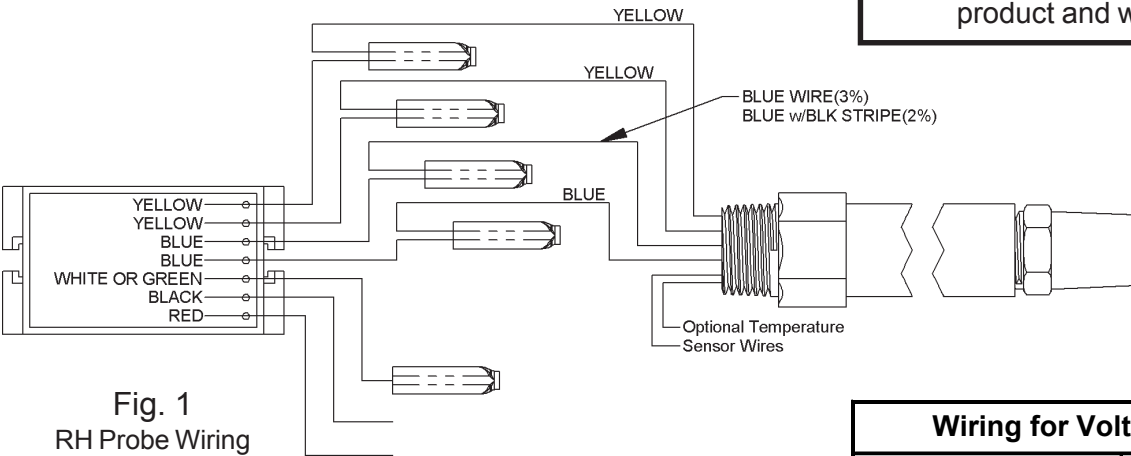

Fig. 1  
RH Probe Wiring



BAPI does not recommend wiring the sensor with power applied as accidental arcing may damage the product and will void the warranty

Wiring for Voltage Output Units	
Wire Color	Connection
Red	Power, 15 to 24 VDC
Black	Ground
White (0-5VDC) or Green (0-10VDC)	Sensor output voltage, to analog input of controller

Wiring for 4-20 mA Output Units	
Wire Color	Connection
Red	Power, 15 to 24 VDC
Black	4-20 mA Output, to analog input of controller
White (0-5VDC) or Green (0-10VDC)	Not Used

### INSTALLATION

1. Remove power from the unit you wish to replace.
2. Disconnect the old probe by cutting the wires as close to the crimp-on connectors as possible.
3. Remove the old probe from the assembly.
4. Retain the Regal locknut (if applicable) when you remove and discard the old probe.
5. Mount the new probe into the box using the Regal locknut retained in step 3 (if applicable). Place the wires through the enclosure mounting hole and slip the nut over the wires and before you splice the wires together.
6. Place like colored wires together from the probe to the transmitter as shown in Figure 1.
7. Place a supplied sealant filled connector over each pair of wires and crimp in place. Make several crimps across the connector. Start at the closed end and work your way to the open end. (You do not need to strip the insulation; the sealant filled connector will pierce the insulation and make a continuous electrical connection.)
8. If an optional temperature sensor is used, connect its wires as described in steps 6 and 7.
9. Restore power.

Optional Temperature Sensor Lead Wire Colors			
Thermistors			
2K $\Omega$	Brown/Brown	10K-3 $\Omega$	Yellow/Red
2K-2 $\Omega$	Brown/Orange	10K3(11K) $\Omega$	Yellow/Blue
3K $\Omega$	Yellow/Black	20K $\Omega$	White/White
10K-2 $\Omega$	Yellow/Yellow	100K $\Omega$	Yellow/White
Platinum RTD			
	Single Point Two Wire		Single Point Three Wire
100 $\Omega$	Red/Red		Red/Red/Black
1K $\Omega$	Orange/Orange		Orange/Orange/Black

Specifications subject to change without notice.



### Troubleshooting

#### **POSSIBLE PROBLEMS:**

General troubleshooting

#### **POSSIBLE SOLUTIONS:**

- Determine that the input is set up correctly in the controller's and building automation software.
- Check wiring for proper termination
- Check for corrosion at either the controller or the sensor. Clean off the corrosion, re-strip the interconnecting wire and reapply the connection. In extreme cases, replace the controller, interconnecting wire and/or sensor.
- Label the terminals that the interconnecting wires are connected to at the sensor end and the controller end. Disconnect the interconnecting wires from the controller and the sensor. With the interconnecting wires separated at both ends measure the resistance from wire-to-wire with a multimeter. The meter should read greater than 10 Meg-ohms, open or OL depending on the meter you have. Short the interconnecting wires together at one end. Go to the other end and measure the resistance from wire-to-wire with a multimeter. The meter should read less than 10 ohms (22 gauge or larger, 250 feet or less). If either test fails, replace the wire.

Humidity transmitter will not operate

- Check power supply/controller voltage supply for +15 VDC to +24 VDC.
- Disconnect humidity transmitter power wires, check the wire coming from the power supply for +15 VDC to +24 VDC.

Humidity reading is maximum 10V or 100%

- Make sure that the sensor is installed properly and is not shorted.
- **Quick Check:** Open one of the Blue wire connections. Does the reading change? If so, the sensor may be faulty, if not contact BAPI technical support.

Humidity reading is minimum 0V or 0%

- Verify that the sensor is installed.
- Did you perform the wiring correctly? Are the two blue wires from the transmitter accidentally connected together?
- **Quick Check:** Short the two Blue wire connections with a short piece of wire. Does the reading change? If so the sensor may be faulty, if not contact BAPI technical support.

Humidity reading in controller's software appears to be off more than the sensor's specified accuracy..

- Check all software parameters.
- If available, check the sensor against a calibrated control such as a hygrometer
- Did you perform the wiring correctly? Are the two yellow wires from the transmitter accidentally connected together?
- Determine if the sensor is exposed to an external source different from the measured environment.

Optional temperature reading is incorrect

- Determine that the temperature sensors wires are connected to the correct controller input terminals and are not loose.
- Check the wires at the sensor for proper connections.
- Measure the physical temperature at the temperature sensor's location using an accurate temperature standard. Disconnect the temperature sensor wires and measure the temperature sensor's resistance across the sensor output pins with an ohmmeter. Compare the temperature sensor's resistance to the appropriate temperature sensor table on the BAPI web site. If the measured resistance is different from the temperature table by more than 5% call BAPI technical support. Find BAPI's web site at [www.bapihvac.com](http://www.bapihvac.com); click on the button labeled SENSORS on the left of the screen and then click on the type of sensor you have. Don't forget to reconnect the wires.

Specifications subject to change without notice.