



Termination of Humidity

BAPI recommends using twisted pair of at least 22AWG and sealant filled connectors for all wire connections. Larger gauge wire may be required for long runs. All wiring must comply with the National Electric Code (NEC) and local codes.

Do NOT run this device's wiring in the same conduit as AC power wiring of NEC class 1 or NEC class 2, NEC class 3 or with wiring used to supply highly inductive loads such as motors, contactors and relays.

BAPI's tests show that fluctuating and inaccurate signal levels are possible when AC power wiring is present in the same conduit as the signal lines. If you are experiencing any of these difficulties, please contact your BAPI representative.



BAPI does not recommend wiring the sensor with power applied as accidental arcing may damage the product and will void the warranty



0 to 10VDC Termination shown with 592 sensor

15 to 35VDC or 12 to 24VAC (See Application Note: "Why Use DC Instead of AC Power" page.)

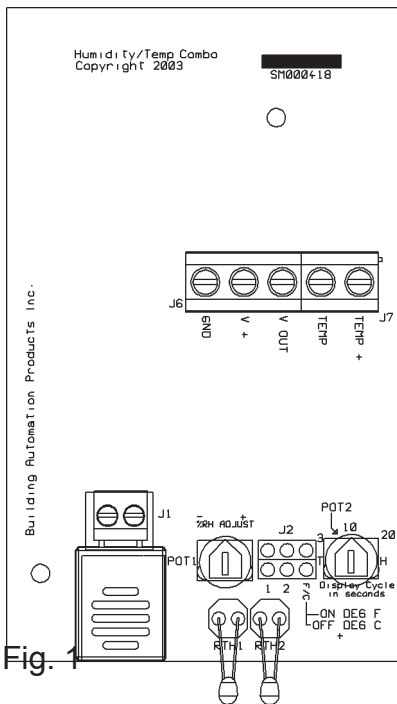

GND(Common)	[To GND(common) from controller]
V+	15 to 35VDC or 12 to 24VAC (See Application Note: "Why Use DC Instead of AC Power page")
VOUT	[0 to 10V FACTORY SET] [To analog input of controller]
TEMP+	[+5 to +30VDC]
TEMP	[Sensor Out]

Digital Display Settings

If shorting block is on the 2-pin header, Degrees = °F
If shorting block is off, Degrees = °C

#1 Factory Only #2 Not Used
Diagram:1 °F/°C Operation

Humidity Offset

Adjusting the pointer will offset the humidity output and display by a varying value up to 3% (+) or (-)

%RHADJUST

- +

Diagram:3 Pot #1

Toggle Rate Adjustment (FOR DISPLAY UNITS ONLY)

The pointer indicates (T) Temperature or (H) Humidity; or, the approximate toggle rate between the two at varying times between 3, 10 and 20 seconds

Settings:

10
3 T H 20

(Display Cycle in seconds)

10 second cycle -

Temperature only -

Humidity only -

Diagram:2 Pot #2



Diagnostics - Humidity

Problems:

- Unit will not operate, display is not working

- Humidity reading is maximum 10V or 100%

- Humidity reading is minimum 0V or 0%

- Humidity reading in software appears to be off more than specified accuracy

- Display will not toggle between Temperature and Humidity

Possible Solutions:

- Check power supply/controller voltage supply.
- Disconnect wires at V+ and GND terminals. Check power wires for power.

- Make sure the sensor is installed properly, and is not shorted.
QUICK CHECK: Remove sensor, readings should change toward 0%

- Verify that the humidity sensor is installed
QUICK CHECK: Short the sensor terminal block with a wire. Readings should change toward 100%.

- Check all control software parameters
- If available, check the sensor against a calibrated control such as a hygrometer
- See the output table on the last page of this document.
- Determine if the sensor is exposed to an external source different from the room environment(conduit draft).

- Check "Toggle Rate Adjustment" pot on the back of the sensor, and make sure the adjustment is correct according to "Diagram 2" on Page 1 of this document.

Output	Humidity Formula
0 to 10 VDC	%RH = V/0.10

Offsetting

This is how BAPI calculates the offset value provided on the equipment label:

Therm Reading _____

The actual temperature reading according to a thermometer that is certified traceable to recognized standards by the National Institute of Standards and Technology (NIST).

Sensor Reading _____

The temperature reading according to the AD592 sensor, using the output in either μ A or mV and converting the output to a Fahrenheit temperature.

Offset _____

The difference between the Thermometer Reading and the Sensor Reading

To correct the Sensor Reading, simply add the offset value to the sensor reading so that it equals the thermometer reading.

e.g. Therm Reading 74.6 Sensor Reading 73.0 Offset +1.6
 Correction: Add (+1.6) °F to the sensor for an accurate reading: 73 + 1.6 = 74.6°F

e.g. Therm Reading 75.4 Sensor Reading 77.2 Offset -1.8
 Correction: Add (-1.6) °F to the sensor for an accurate reading: 77.2 + (-1.8) = 75.4°F



Termination of Temperature

BA/592 (2 Wire) sensors

- 1. Make sure a 10K 0.1% resistor is installed between the sensor output and Ground.
2. Connect the sensor output to the analog input (A.I.).
3. Connect Power (+5 to +30 VDC) to the power.

Diagnostics - Temperature

The AD592AN sensor transforms temperature into current. The output changes 1micro-amp for every one degree Celsius change in temperature (0.56micro-amp per degree Fahrenheit). Since most meters that field technicians use cannot accurately measure currents this low BAPI recommends that a 10,000 ohm 0.1% resistor be placed between the sensor output and ground.

10K Error Table table with columns: 10K Resistor Tolerance, Temperature Inaccuracy. Rows: 0.10%, 1%, 5%.

If the humidity transmitter is set up for 4 to 20mA output there is no signal ground at the sensor to use as a reference for voltage measurements for two wire 592 units. The ground pin at a local power plug may be at the correct potential or you may have to pull a temporary ground wire from the controller in order to make voltage measurements. There will be a ground in 3-wire 592 units.

592 Output Table table with columns: Temperature (°F, °C), Output Current (uA), Output Voltage across 10KΩ. Rows: 50 to 100.

- 1. Set your meter to the Volts setting
2. Measure power from the GND terminal (black meter lead) to the TEMP+ terminal (red meter lead) for +5 to +30 VDC.
3. Remove the controller wire in terminal TEMP
4. Place a 10,000 ohm 0.1% resistor from the terminal TEMP to the terminal GND (leave the controllers wire in the terminal GND)
5. Set your meter to the mV setting.
6. Measure the voltage from the GND terminal (black meter lead) to the TEMP terminal. Compare the voltage measurement to the voltage listed in the sensor output table.
7. If the sensor voltage is higher or lower than expected when you add in the error due to the resistor you used to make the measurement, call BAPI technical support.
8. If the sensor reads properly, verify that the controller is operating correctly.
9. Determine if the sensor is exposed to an external source different from the room environment (conduit draft).
10. Remove resistor and reconnect controller wire to the TEMP terminal.

Mounting

Fig. 2

Mounting hardware is provided for both junction box and drywall installation (junction box installation shown).

Junction Box

1. Pull the wire through the wall and out of the junction box, leaving about six inches free.
2. Pull the wire through the hole in the base plate.
3. Secure the base to the box using the #6-32 x 1/2 inch mounting screw provided.
4. Terminate the unit according to the guidelines in **Termination** on page 1.
5. Attach Cover by latching it to the top of the base, rotating the cover down and snapping it into place.
6. Secure the cover by backing out the lock-down screws using a 1/16" allen wrench until they are flush with the bottom of the cover.

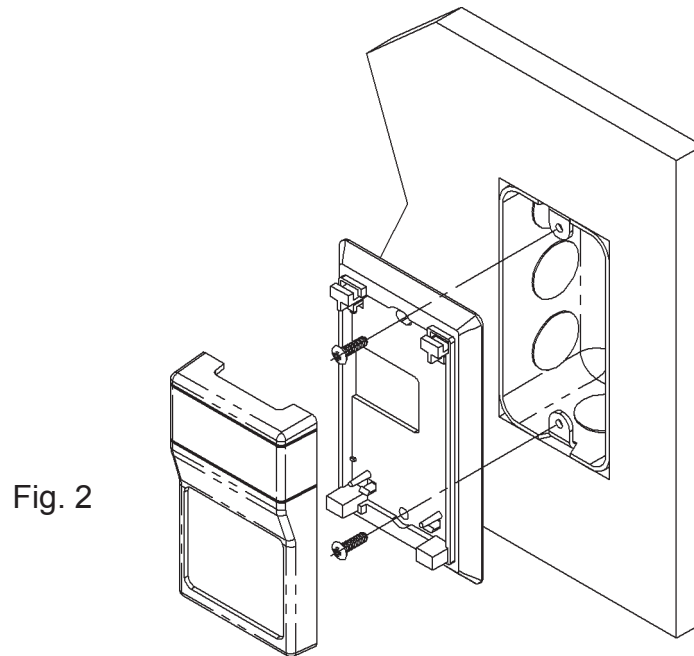
Drywall Mounting

1. Place the base plate against the wall where you want to mount the sensor.
2. Using a pencil mark out the two mounting holes and the area where the wires will come through the wall.
3. Drill two 3/16" holes in the center of each marked mounting hole. Insert a drywall anchor into each hole.
4. Drill one 1/2" hole in the middle of the marked wiring area.
5. Pull the wire through the wall and out of the 1/2" hole, leaving about six inches free.
6. Pull the wire through the hole in the base plate.
7. Secure the base to the drywall anchors using the #6 x 1 inch mounting screws provided.
8. Terminate the unit according to the guidelines in **Termination** on page 1.
9. Attach Cover by latching it to the top of the base, rotating the cover down and snapping it into place.
10. Secure the cover by backing out the lock-down screws using a 1/16" allen wrench until they are flush with the bottom of the cover.

NOTE

In a wall-mount application, the wall temperature and the temperature of the air within the wall cavity can cause erroneous readings. The mixing of room air and air from within the wall cavity can lead to condensation, erroneous readings and premature failure of the sensor.

To prevent these conditions, seal the conduit leading to the junction box and seal the hole in the drywall by using an adhesive backed, foam insulating pad.



HUMIDITY Transmitter Output Table

%RH	mA	10V	%RH	mA	10V
0	4.000	0.00	50	12.000	5.00
1	4.160	0.10	51	12.160	5.10
2	4.320	0.20	52	12.320	5.20
3	4.480	0.30	53	12.480	5.30
4	4.640	0.40	54	12.640	5.40
5	4.800	0.50	55	12.800	5.50
6	4.960	0.60	56	12.960	5.60
7	5.120	0.70	57	13.120	5.70
8	5.280	0.80	58	13.280	5.80
9	5.440	0.90	59	13.440	5.90
10	5.600	1.00	60	13.600	6.00
11	5.760	1.10	61	13.760	6.10
12	5.920	1.20	62	13.920	6.20
13	6.080	1.30	63	14.080	6.30
14	6.240	1.40	64	14.240	6.40
15	6.400	1.50	65	14.400	6.50
16	6.560	1.60	66	14.560	6.60
17	6.720	1.70	67	14.720	6.70
18	6.880	1.80	68	14.880	6.80
19	7.040	1.90	69	15.040	6.90
20	7.200	2.00	70	15.200	7.00
21	7.360	2.10	71	15.360	7.10
22	7.520	2.20	72	15.520	7.20
23	7.680	2.30	73	15.680	7.30
24	7.840	2.40	74	15.840	7.40
25	8.000	2.50	75	16.000	7.50
26	8.160	2.60	76	16.160	7.60
27	8.320	2.70	77	16.320	7.70
28	8.480	2.80	78	16.480	7.80
29	8.640	2.90	79	16.640	7.90
30	8.800	3.00	80	16.800	8.00
31	8.960	3.10	81	16.960	8.10
32	9.120	3.20	82	17.120	8.20
33	9.280	3.30	83	17.280	8.30
34	9.440	3.40	84	17.440	8.40
35	9.600	3.50	85	17.600	8.50
36	9.760	3.60	86	17.760	8.60
37	9.920	3.70	87	17.920	8.70
38	10.080	3.80	88	18.080	8.80
39	10.240	3.90	89	18.240	8.90
40	10.400	4.00	90	18.400	9.00
41	10.560	4.10	91	18.560	9.10
42	10.720	4.20	92	18.720	9.20
43	10.880	4.30	93	18.880	9.30
44	11.040	4.40	94	19.040	9.40
45	11.200	4.50	95	19.200	9.50
46	11.360	4.60	96	19.360	9.60
47	11.520	4.70	97	19.520	9.70
48	11.680	4.80	98	19.680	9.80
49	11.840	4.90	99	19.840	9.90
			100	20.000	10.00