

Termination

BAPI recommends using twisted pair of at least 22AWG and sealant filled connectors for all wire connections. Larger gauge wire may be required for long runs. All wiring must comply with the National Electric Code (NEC) and local codes.

Do NOT run this device's wiring in the same conduit as AC power wiring of NEC class 1, NEC class 2, NEC class 3 or with wiring used to supply highly inductive loads such as motors, contactors and relays. BAPI's tests show that fluctuating and inaccurate signal levels are possible when AC power wiring is present in the same conduit as the signal lines. If you are experiencing any of these difficulties, please contact your BAPI representative

 BAPI does not recommend wiring the sensor with power applied as accidental arcing may damage the product and will void the warranty

Fig. 1



Unit	Wire Color	Wire Length	# of Wires	Connection
Display	(Optional) Black	6"	2	To Vivarium Plate 24"opt.
Display	Yellow	6"	2	To Vivarium Plate Yellow 12"
Display	Blue	6"	2	To Vivarium Plate Blue 12"
Vivarium Plate	Yellow	12"	2	To Display Yellow
Vivarium Plate	3% = 2 Blue, 2% = 1 Blue & 1 Blue w/Black Stripe	12"	2	To Display Blue
Vivarium Plate	(Optional) See Sensor Table below for color	24"	2	To Display Black

Table 2

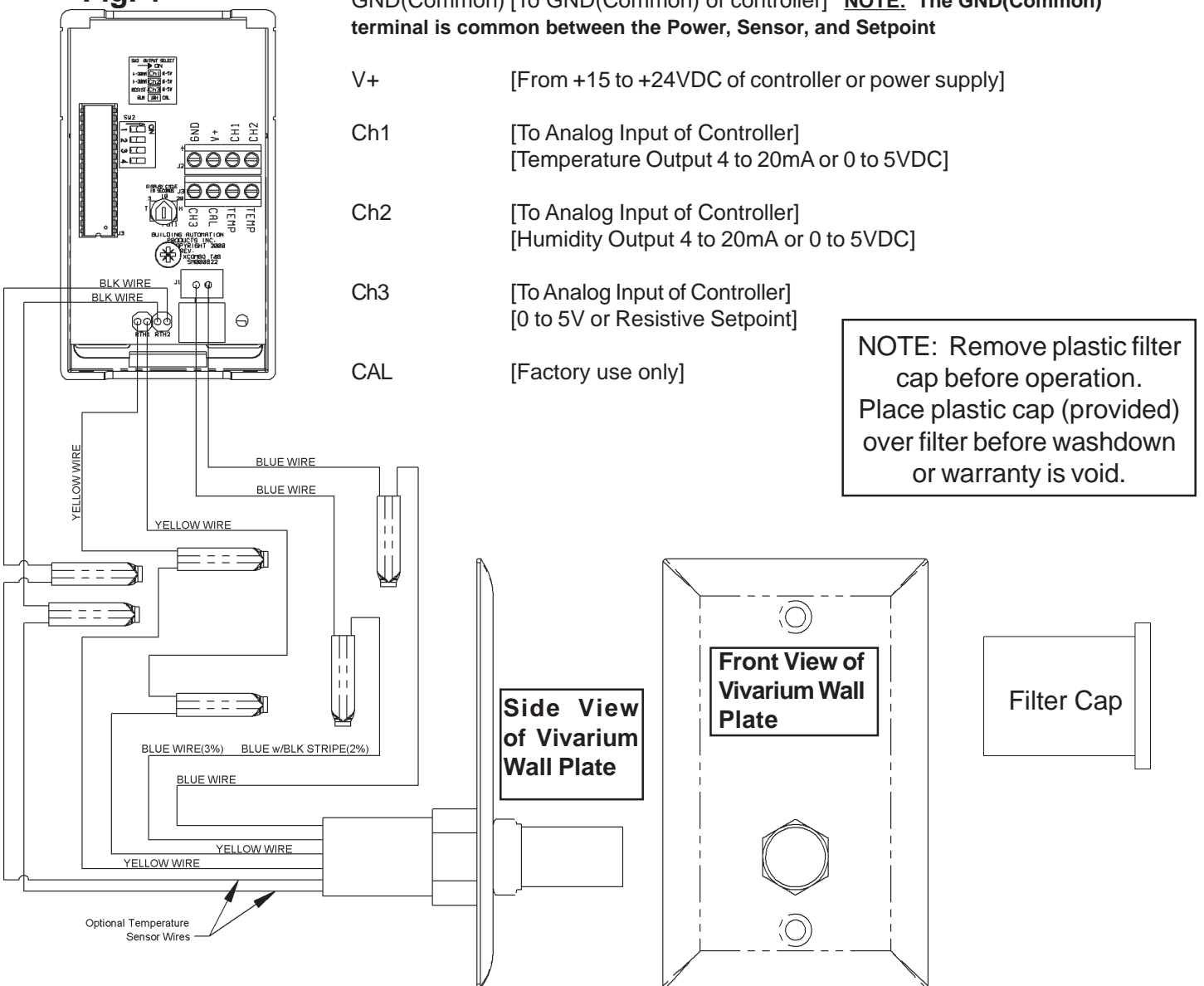
Thermistor		2K Ω	Brown/Brown	
3K	Yellow/Black	2K-2	Brown/Orange	
10K-2	Yellow/Yellow	<u>Platinum RTD</u>		
10K-3	Yellow/Red		<u>Single Point Two Wire</u>	<u>Single Point Three Wire</u>
10K3(11K)	Yellow/Blue		Red/Red	Red/Red/Black
20K	White/White	100 Ω	Red/Red	Red/Red/Black
100K	Yellow/White	1K Ω	Orange/Orange	Orange/Orange/Black

Filter Cover

Please install rubber protective cover over stainless steel filter before any washdown procedures begin. This will insure the correct operation of the sensor.

Front Panel Description

When the setpoint buttons are pressed "UP" or "DOWN" the current setpoint will display, then as the buttons are pressed again the display will change with each press.

While in setpoint mode, override button toggles between temperature setpoint and humidity setpoint. If an override has been selected by pressing the override once, a momentary override will occur on Channel 3, and (Or) will flash on the display. When the "OVERRIDE" is pressed the display will show "Or"

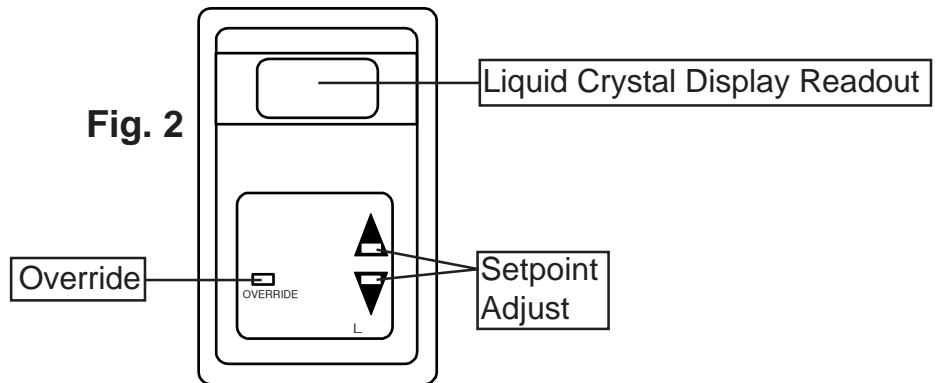

Digital Display Settings

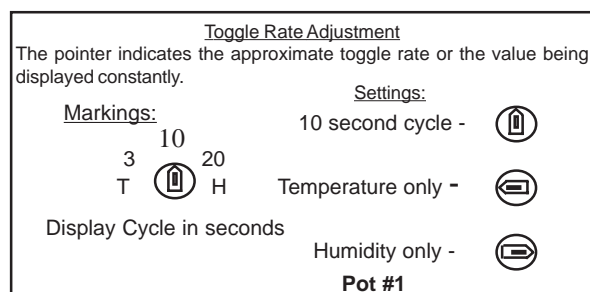
Fig. 3



%RH and Temperature Output Adjustment

In the case of the unit needing to be adjusted to match a customer unit, follow the adjustment procedure below:

- 1) Determine the value adjustment needed.
- 2) Remove cover from backplate and slide the “%RH” switch on SW2 to the “CAL” position.
- 3) Use the up and down arrows on front to select the calibration needed. Use the Override button to toggle back and forth from Humidity to Temperature. The adjustment can be +/-5 for both Humidity and Temperature.
- 4) Set the “%RH” switch on SW2 back to “RUN” and put the cover on the backplate.

Troubleshooting - Humidity

Possible Problems:

Unit will not operate

Humidity reading is maximum 20mA, 5V or 100%

Humidity reading is minimum 4mA, 0V or 0%

Humidity reading in software appears to be off more than specified accuracy

Display is not working

Display will not toggle between Temperature and Humidity

Display keeps resetting when “VOUT” terminal is connected to control

Possible Problems:

- Check +15 to +24VDC power supply at controller.
- Disconnect sensor and check power wires for +24VDC.

- Make sure the sensor is installed properly, and is not shorted.
QUICK CHECK: Remove sensor(open the blue wires), if reading does not change, contact *BAPI* technical support.

- Verify that the humidity sensor is installed.
QUICK CHECK: Short the sensor terminal block(short the blue wires) with a wire. Does the reading change? If so, the sensor may be faulty, if not contact *BAPI* technical support.

- Check all software parameters
- If available, check the sensor against a calibrated control such as a hygrometer
- Determine if the sensor is exposed to an external source different from the room ambient
- Determine if the sensor is exposed to an external source different from the room environment(Conduit Draft)

- Use “Unit will not operate” solutions.
- Check that the V+ terminal has +15 to +24VDC
- If outputs are correct, but display is not operating, contact *BAPI* technical support.

- Check “Toggle Rate Adjustment” switch on the back of the sensor, and make sure the adjustment is correct according to Diagram on page 2.

- Make sure the maximum current draw is below 20mA

Troubleshooting Temperature

Possible Problems:

Controller reports higher than actual temperature

Possible Solutions:

- Confirm the input is set up correctly in the front end software
- Verify that the wires are not physically shorted
- Check wiring for proper termination
- Disconnect wires and measure sensor resistance with an Ohm meter, (Refer to the appropriate sensor output table at www.bapihvac.com)
- Determine if the sensor is exposed to an external source different from the room environment(conduit draft)

Controller reports lower than actual temperature

- Confirm the input is set up correctly in the front end software
- Verify that the thermistor is not physically open
- Check wiring for proper termination
- Disconnect wires and measure sensor resistance with an Ohm meter, (Refer to the appropriate sensor output table at www.bapihvac.com)
- Determine if the sensor is exposed to an external source different from the room environment(conduit draft)

Sensor reading is significantly off from LCD

- Check control connection
- Disconnect wires and measure the sensor with an Ohm meter.
- Compare reading to appropriate sensor table
- Verify the specified thermistor is correct

Display is reading °C instead of °F or °F instead of °C temperature

- Check to make sure J2 is installed correctly according to Diagram 1 on Page 4 of this document

Mounting

Figure 3: Display Unit & Vivarium Sensor Plate Mounting on Opposite Sides of the Same Wall.

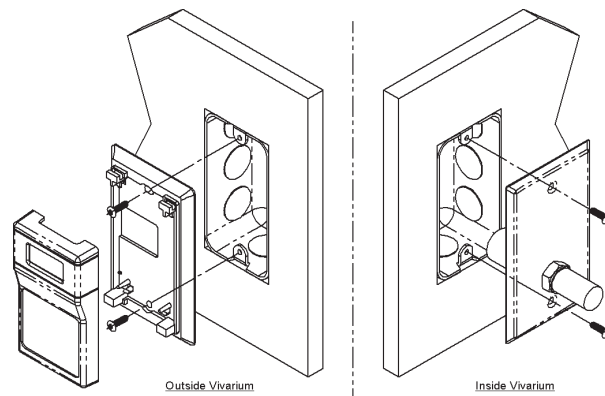

1. Mount two junction boxes on opposite sides of the same wall. One side of the wall is the vivarium and the other side of the wall is where the display unit will be installed. Place the boxes close enough together that the wire on the vivarium plate and the display unit can reach one another. . DO NOT add extra wire between the transmitter and the wall plate, BAPI provides the maximum allowed wire length between the units.
2. Secure the display unit base to the junction box outside the vivarium using the #6-32 x 1/2 inch mounting screws provided.
3. Run the wires from the vivarium plate through the junction box in the vivarium into the junction box for the display unit. Secure the vivarium plate to the vivarium junction box with the #6-32 x 1/2 inch mounting screws provided making sure the foam on the back of the vivarium plate makes a good seal with the wall.
4. Using BAPI sealant filled connectors, terminate the unit according to the guidelines in **Termination** on page 1.
5. Attach Cover by latching it to the top of the base, rotating the cover down and snapping it into place.
6. Secure the cover by backing out the lock-down screws using a 1/16" Allen wrench until they are flush with the bottom of the cover.