



# CO<sub>2</sub> Room Sensor in a BAPI-Stat 4 Enclosure

Installation and Operating Instructions

28172\_ins\_BS4\_CO2

rev. 02/01/12

## Identification and Overview

The BAPI CO<sub>2</sub> Sensor in the BAPI-Stat 4 Enclosure is an accurate and reliable way of incorporating demand controlled ventilation into a building's HVAC strategy. It measures the CO<sub>2</sub> in a range of 0 to 2,000 ppm with a field selectable output of 0 to 5 or 0 to 10 VDC.

The BAPI unit also has continuous automatic Barometric pressure compensation. Air pressure changes from altitude or weather patterns can affect the output of CO<sub>2</sub> sensors, even putting them outside of their specified accuracy. The BAPI unit has a built-in barometric sensor that continuously compensates the output for accurate readings despite the weather or the altitude of the installation. Because of this feature, the BAPI CO<sub>2</sub> sensor received a 2012 AHR Expo Innovation Award.

Optional indication of the CO<sub>2</sub> level as "Good, Fair or Poor" is available as a three-color LED on the front of the unit.

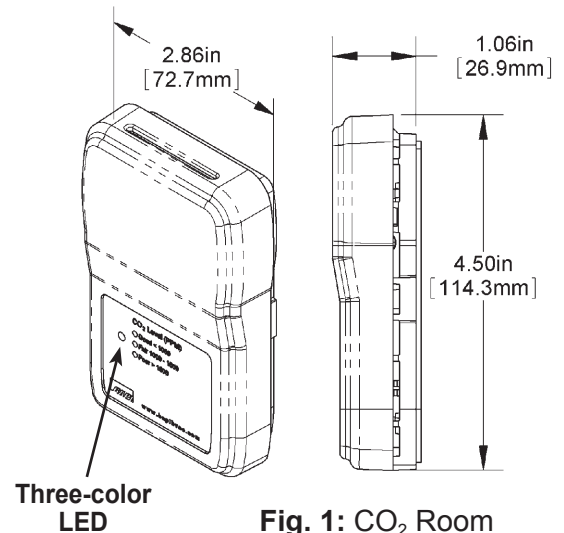

**Fig. 1:** CO<sub>2</sub> Room Sensor in a BAPI-Stat 4 Enclosure

## Specifications

### Power:

12 to 30 VAC, 1.8 VA avg, 12 VA peak  
12 to 24 VDC, 30 mA avg, 200 mA peak

### CO<sub>2</sub> Sensing Elements:

Single Beam Non-Dispersive Infrared (NDIR)  
or Dual Channel NDIR for "24/7" Model

**Selectable Output:** 0 to 2,000 PPM CO<sub>2</sub>  
0 to 5 VDC or 0 to 10 VDC

**Termination:** 3 Terminals, 16 to 22 AWG

**Wiring:** 2 Pair

### Operating Environment:

32 to 122°F (0 to 50°C)  
0 to 95%RH non-condensing

### Enclosure Material:

ABS Plastic, Material Rated UL94V-O

**CO<sub>2</sub> Detection Range:** 0 to 2000 ppm

**Start-Up Time:** 10 Minutes

### Response Time:

Less Than 5 Minutes (after Start-Up Time)

**Mounting:** 2"x4" J-Box or drywall – screws provided

**CO<sub>2</sub> Accuracy:** (Automatic Background Calibration model)  
400 to 1,250 ppm: ±30ppm or 3% of reading,  
whichever is greater

1,250 to 2,000 ppm: ±5% of reading + 30ppm

**CO<sub>2</sub> Accuracy:** ("24/7" Model)  
±75ppm

### Optional LED CO<sub>2</sub> Level Indicator:

Good, Green < 1,000 PPM  
Fair, Orange = 1,000 to 1,500 PPM  
Poor, Red > 1,500 PPM

**Certifications:** RoHS

### Warranty Period:

2 Years from manufacture date

Specifications subject to change without notice.



# CO<sub>2</sub> Room Sensor in a BAPI-Stat 4 Enclosure

Installation and Operating Instructions

28172\_ins\_BS4\_CO2

rev. 02/01/12

## Mounting

Mounting hardware is provided for both junction box and drywall installation (junction box installation shown).

Note: Screw the 1/16" Allen lock-down screw into the base to open the case. Back out the lock-down screw to secure the cover.

### Junction Box

1. Pull the wire through the wall and out of the junction box, leaving about six inches free.
2. Pull the wire through the hole in the base plate.
3. Secure the plate to the box using the #6-32 x 5/8 inch mounting screws provided.
4. Terminate the unit according to the guidelines in the Termination section. (page 3)
5. Mold the foam on the unit's base to the wire bundle to prevent drafts. (see note below)
6. Attach Cover by latching it to the top of the base, rotating the cover down and snapping it into place.
7. Secure the cover by backing out the lock-down screw using a 1/16" Allen wrench until it is flush with the bottom of the cover.

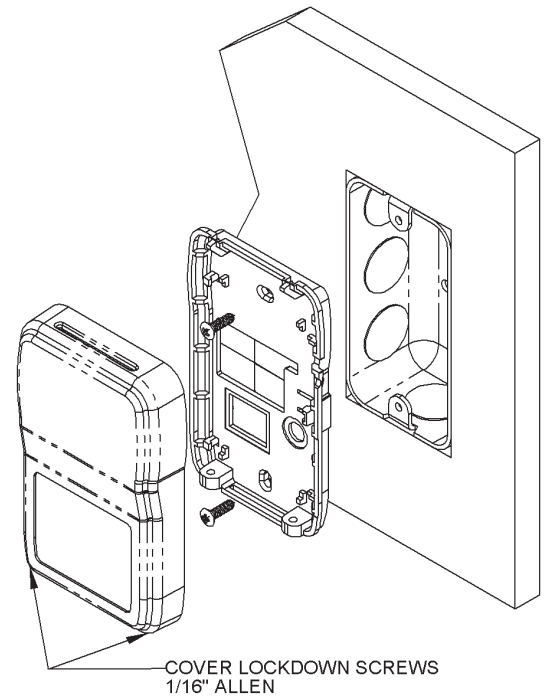

Fig. 2: Mounting to a Junction Box

### Drywall Mounting

1. Place the base plate against the wall where you want to mount the sensor.
2. Mark out the two mounting holes and the area where the wires will come through the wall.
3. Drill two 3/16" holes in the center of each marked mounting hole, DO NOT punch the holes or the drywall anchors will not hold. Insert a drywall anchor into each hole.
4. Drill one 1/2" hole in the middle of the marked wiring area.
5. Pull the wire through the wall and out of the 1/2" hole, leaving about six inches free.
6. Pull the wire through the hole in the base plate.
7. Secure the base to the drywall anchors using the #6 x 1 inch mounting screws provided.
8. Terminate the unit according to the guidelines in the Termination section. (page 3)
9. Mold the foam on the unit's base to the wire bundle to prevent drafts. (see note below)
10. Attach cover by latching it to the top of the base, rotating the cover down and snapping it into place.
11. Secure the cover by backing out the lock-down screw using a 1/16" Allen wrench until it is flush with the bottom of the cover.

NOTE: In any wall-mount application, the wall temperature and the temperature of the air within the wall cavity can cause erroneous readings. The mixing of room air and air from within the wall cavity can lead to condensation, erroneous readings and sensor failure. To prevent these conditions, BAPI recommends sealing the conduit leading to the junction box, filling the junction box with fiberglass insulation or sealing the wall cavity.

Specifications subject to change without notice.



# CO<sub>2</sub> Room Sensor in a BAPI-Stat 4 Enclosure

Installation and Operating Instructions

28172\_ins\_BS4\_CO2

rev. 02/01/12

## Termination

BAPI recommends using twisted pair of at least 22AWG and sealant filled connectors for all wire connections. Larger gauge wire may be required for long runs. All wiring must comply with the National Electric Code (NEC) and local codes.

Do NOT run this device's wiring in the same conduit as AC power wiring of NEC class 1, NEC class 2, NEC class 3 or with wiring used to supply highly inductive loads such as motors, contactors and relays. BAPI's tests show that fluctuating and inaccurate signal levels are possible when AC power wiring is present in the same conduit as the signal lines. If you are experiencing any of these difficulties, please contact your BAPI representative.



BAPI recommends against wiring the sensor with power applied as accidental arcing may damage the product and void the warranty.

Note: Unit is not ready for operation until the ten-minute start-up time has elapsed.

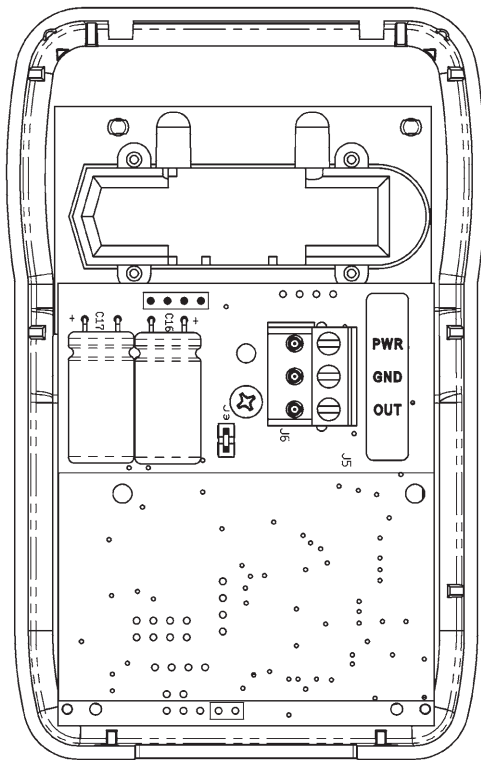

Fig. 3: Circuit Board

### Terminal PWR

### Function

12 to 30 VAC, 1.8 VA avg, 12 VA peak  
12 to 24 VDC, 30 mA avg, 200 mA peak

### GND

To controller Ground [GND or Common]

### OUT

Voltage Output, CO<sub>2</sub> Signal (0 to 2,000 ppm)  
0 to 5 or 0 to 10 VDC, Referenced to GND

**Note:** The CO<sub>2</sub> Output may be field configured for 0 to 5 or 0 to 10 VDC outputs at any time. Set the Jumper on J3 as shown in Fig. 4 & 5 below.

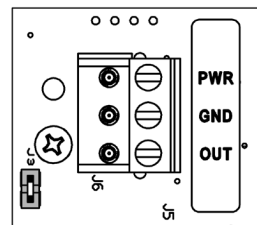

Fig. 4: J3 Set for 0 to 10 VDC Output

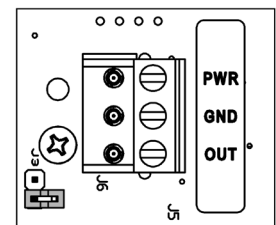

Fig. 5: J3 Set for 0 to 5 VDC Output

Specifications subject to change without notice.



# CO<sub>2</sub> Room Sensor in a BAPI-Stat 4 Enclosure

Installation and Operating Instructions

28172\_ins\_BS4\_CO2

rev. 02/01/12

## Diagnostics

### Possible Problems:

General troubleshooting

### Possible Solutions:

Determine that the input is set up correctly in the controller's and building automation software.

Check wiring at the sensor and controller for proper connections.

Check for corrosion at either the controller or the sensor. Clean off the corrosion, re-strip the interconnecting wire and reapply the connection. In extreme cases, replace the controller, interconnecting wire and/or sensor.

Check the wiring between the sensor and controller. Label the terminals at the sensor end and the controller end. Disconnect the interconnecting wires from the controller and the sensor. With the wires disconnected, measure the resistance from wire-to-wire with a multimeter. The meter should read greater than 10 Meg-ohms, open or OL depending on the meter. Short the interconnecting wires together at one end. Go to the other end and measure the resistance from wire-to-wire with a multimeter. The meter should read less than 10 ohms (22 gauge or larger, 250 feet or less). If either test fails, replace the wire.

Check power supply/controller voltage supply

Disconnect sensor and check power wires for proper voltage (see specifications on page 1)

Incorrect CO<sub>2</sub>

Wait 15 minutes after a power interruption.

Check all BAS controller software parameters.

Determine if the sensor is exposed to an external environment different from the room environment (conduit draft).

Specifications subject to change without notice.