

# BAPI-Stat 3™ Room Unit

Humidity & Combination Temp/Humidity Sensors



Rev. 07/20/11

## Large Display & Membrane Pushbuttons

### Features & Options

- Designed for Operating Rooms and Clean Rooms
- Large Easy-to-Read Display
- Humidity Only or Combination Temp./Humidity
- Membrane Pushbuttons for Wipedown Cleaning
- Adjustable Temperature and Humidity Setpoints and Override
- Wide Selection of Temperature Sensors
- 2% RH Accuracy
- Two Year Warranty



**BAPI-Stat 3 Units with Gray Keypad and Off White Keypad**

The BAPI-Stat 3 is designed for operating rooms, clean rooms and elder care facilities. It features an easy-to-read display and membrane pushbuttons for wipedown cleaning. It is available as a temperature sensor alone or as a combination temp./humidity sensor. Depending upon the options selected, the BAPI-Stat can display room temp., room humidity, temp. setpoint, humidity setpoint and override status.

The unit includes a number of field adjustments including °F or °C display, temperature offset ( $\pm 5$  °F or °C in increments of 0.1°), RH offset ( $\pm 5\%$  in increments of 0.1%), or setpoint lockout (which disables the setpoint pushbuttons). The display can also be set to show a large temperature and small RH, a large RH and a small temperature, or to alternate between these two settings every 5 seconds. The unit is available with the full line of BAPI temperature sensors.

### The BAPI-Guard

- Prevents Tampering, Damage and Unauthorized Adjustment
- Exceptional Airflow for Proper Thermostat Operation
- Two Sizes to Fit Most Thermostats



**BAPI-Guard Mounted Over a Thermostat**

(See Accessories for more info.)

**For detailed specs on the individual Sensors & Transmitters, turn to the Sensors section.**

## Specifications

**Power:** 10 to 35 VDC (15 to 24 VDC recommended) for 4 to 20 mA or 0 to 5 VDC Outputs  
 15 to 35 VDC (15 to 24 VDC recommended) for 0 to 10 VDC Output  
 12 to 28 VAC (Requires a separate pair of shielded wires) for 0 to 5 VDC Outputs  
 15 VAC to 28 VAC (Requires a separate pair of shielded wires) 0 to 10 VDC Output

### Power Consumption:

60 mA max. DC: 4 to 20 mA or 0 to 5 VDC Outputs  
 10 mA max. DC: 0 to 10 VDC Output  
 1.44 VA max. AC: 0 to 5 VDC Outputs  
 0.2 VA max. AC: 0 to 10 VDC Output

### Sensing Elements:

Temp. - Semiconductor Band Gap,  
 Proportional to Absolute Temperature,  $\pm 0.3^\circ\text{C}$   
 Humidity - Capacitive Polymer,  $\pm 2\%$  RH Accuracy  
 Optional Direct Temp. Sensor - Therm., RTD or Semicond.

**Mounting:** 2" by 4" J-box or drywall mount - screws provided

### Environmental Specifications:

Temperature: 32 to 122 °F (0 to 50 °C)  
 Humidity: 0 to 95%, non-condensing

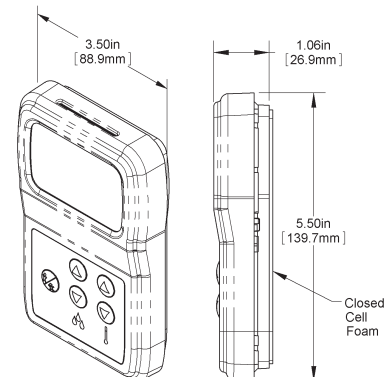

**Wiring:** 2 to 4 pair of 16 to 22 AWG\*

**Material:** ABS Plastic - UL 94, V-0

\* BAPI recommends that you do not run wiring for Room Units in the same conduit as line voltage wiring or with wiring used to supply highly inductive loads such as motors, generators, and coils.



# BAPI-Stat 3™ Room Unit B9

## Humidity & Combination Temp/Humidity Sensors

Rev. 07/20/11

Ordering Information BAPI-Stat 3 Room Unit - Temperature, Humidity or Combination									
<b>BA/BS3</b>									
<b>Temperature Display Mode</b>									
<b>F</b>	Temperatures Displayed in °F								
<b>C</b>	Temperatures Displayed in °C								
<b>Humidity Sensor Accuracy (skip if ordering a temperature only unit)</b>									
<b>2</b>	Accuracy in % for the Relative Humidity Output (i.e. ±2% RH)								
<b>Channel # 1* - T, H, R are placeholders for the range options. (See inset charts)</b>									
<b>-0 T</b>	Temperature Output, 4 - 20 mA								
<b>-1 T</b>	Temperature Output, 0 - 5 V								
<b>-2 T</b>	Setpoint Output, Temperature 4 - 20 mA								
<b>-3 T</b>	Setpoint Output, Temperature 0 - 5 V								
<b>-4 H</b>	Setpoint Output, %RH 4 - 20 mA								
<b>-5 H</b>	Setpoint Output, %RH 0 - 5V								
<b>-6 T</b>	Temperature Output 0 - 10V								
<b>-7 T</b>	Setpoint Output, Temperature 0 - 10V								
<b>-8 H</b>	Setpoint Output, %RH 0 - 10V								
<b>Channel # 2* - T, H, R are placeholders for the range options. (See inset charts)</b>									
<b>-10 H</b>	%RH Output, 4 - 20 mA								
<b>-11 H</b>	%RH Output, 0 - 5 V								
<b>-12 T</b>	Setpoint Output, Temperature 4 - 20 mA								
<b>-13 T</b>	Setpoint Output, Temperature 0 - 5 V								
<b>-14 H</b>	Setpoint Output, %RH 4 - 20 mA								
<b>-15 H</b>	Setpoint Output, %RH 0 - 5 V								
<b>-16 H</b>	%RH Output, 0 - 10 V								
<b>-17 T</b>	Setpoint Output, Temperature 0 - 10 V								
<b>-18 H</b>	Setpoint Output, %RH 0 - 10 V								
<b>Optional Additional Outputs Ch 3 &amp; 4 - T, H, R are placeholders for range options. (See inset charts)</b>									
<b>-20 T R G</b>	Setpoint Output, Temperature Resistive w/ Override (DF is wired to Channel 3 & 4)								
<b>-22 H R G</b>	Setpoint Output, %RH Resistive w/ Override (DF is wired to Channel 3 & 4)								
<b>-24 T R G</b>	Setpoint Output, Temperature Resistive w/o Override (DF is wired to Channel 3 & 4)								
<b>-25 T R G</b>	Setpoint Output, Temperature voltage w/o Override (Common Ground required)								
<b>-26 H R G</b>	Setpoint Output, %RH Resistive w/o Override (DF is wired to Channel 3 & 4)								
<b>-27 H R G</b>	Setpoint Output, %RH Voltage w/o Override (Common Ground required)								
<b>-28 G</b>	Override Only [High Ω -> Low Ω -> High Ω] (DF is wired to Channel 3 & 4)								
<b>-29 G</b>	Override Only [5 V -> 0 V -> 5V] (Common Ground required)								
<b>Optional Override Ch 3 or 4 - dry contact</b>									
<b>-60 G</b>	Dry Contact Override Ch4 (If the unit is DF, use terminals CH3 & CH4)								
<b>-61 G</b>	Dry Contact Override Ch5 [Temp - Temp]								
<b>Optional Sensor Type Ch 5 (if resistive sensor required)</b>									
<b>-0</b>	100 Platinum RTD, 100 Ω @ 0 °C, 0.385 Ω/°C temp. coeff.								
<b>-1375</b>	1K Platinum RTD, 1,000 Ω @ 0 °C, 3.75 Ω/°C temp. coeff.								
<b>-1N1</b>	1K Ω Nickel RTD, 1,000 Ω @ 21°C, 5 Ω/°C temp. coeff.								
<b>-1</b>	1K Platinum RTD, 1,000 Ω @ 0 °C, 3.85 Ω/°C temp. coeff.								
<b>-2</b>	2K Silicon RTD, 2,000 Ω @ 20 °C, 8 Ω/°C temp. coeff.								
<b>-18</b>	1.8K Thermistor, 1,800 Ω @ 25 °C								
<b>-3</b>	3K Thermistor, 3,000 Ω @ 25 °C								
<b>-33</b>	3.3K Thermistor, 3,300 Ω @ 25 °C								
<b>-102</b>	10K-2 Thermistor, 10,000 Ω @ 25 °C								
<b>-103</b>	10K-3 Thermistor, 10,000 Ω @ 25 °C								
<b>-10311</b>	10K-3[11K] Therm., 5,238 Ω @ 25 °C, 11kΩ shunt resistor								
<b>-20</b>	20K Thermistor, 20,000 Ω @ 25 °C								
<b>-50</b>	50K Thermistor, 50,000 Ω @ 25 °C								
<b>-100</b>	100K Thermistor, 100,000 Ω @ 25 °C								
<b>-592</b>	AD592 Semiconductor, 273 μA @ 0 °C								
<b>-ES</b>	External Sensor connection. 10K-2 thermistor purchased separately.***								
<b>Optional Communication Jack</b>									
<b>-C11L</b>	RJ11 (4 pin) Style Jack with Leads								
<b>-C11LT</b>	RJ11 (4 pin) Style Jack w/ Leads and Terminal Block								
<b>-C35L</b>	3.5 mm Phono Jack w/ Leads Attached								
<b>-C35LT</b>	3.5 mm Phono Style Jack w/ Leads and Term. Block								
<b>-C22L</b>	RJ22 (4 pin) Style Jack with Leads Attached								
<b>-C22LT</b>	RJ22 (4 pin) Style Jack with Leads and Terminal Block								
<b>Optional Test &amp; Balance Switch**</b>									
<b>-TB</b>	Three Position Switch - "Low" & "High" values vary, "Normal" is live sensor value, call for details.*								
<b>Keypad Color Must Select One</b>									
<b>-GRY</b>	Gray Keypad Color								
<b>-OFW</b>	Off White Keypad Color								

R = Output Range Designator		
Designator	Output Range	Span
00	0 to 5 V	5 Volts
01	1 to 5 V	4 Volts
02	3.7 to 0.85 V	2.85 Volts
03	5 to 0 V	5 Volts
04	4.2 to 1.2 V	3 Volts
10	0 to 10 V	10 Volts
20	889 to 111 Ω	778Ω
21	792 to 208 Ω	584Ω
22	695 to 305 Ω	390Ω
23	674 to 274 Ω	400Ω
24	597 to 305 Ω	292Ω
25	800 to 1200	400Ω
26	909 to 1309	400Ω
27	1800 to 2200	400Ω
28	866 to 1286	400Ω
40	0 to 1 kΩ	1 kΩ
41	500 to 1500 Ω	1 kΩ
42	2 to 3 kΩ	1 kΩ
43	249 to 1249 Ω	1 kΩ
44	10 to 11 kΩ	1 kΩ
45	12.5K-11.5K Ω	1 kΩ
46	1K to 0 Ω	1 kΩ
47	182 to 1182 Ω	1 kΩ
50	0 to 5 kΩ	5 kΩ
51	7.87k to 2.87kΩ	5 kΩ
60	0 to 10 kΩ	10 kΩ
61	15 to 5 kΩ	10 kΩ
62	9577 to 1422 Ω	
63	1 to 11 kΩ	10 kΩ
64	200 to 10200	10 kΩ
80	0 to 20 kΩ	20 kΩ
81	4.75 to 24.75 kΩ	20 kΩ
82	6.19 to 26.19 kΩ	20 kΩ
83	7.87 to 27.87 kΩ	20 kΩ
84	10 to 30 kΩ	20 kΩ

T = Temperature, Output & Display Range		
	°F	°C
A	-3 to +3	-3 to +3
B	-5 to +5	-5 to +5
C	50 to 90 °F	10 to 32 °C
D	55 to 85 °F	13 to 30 °C
E	60 to 80 °F	15 to 27 °C
F	65 to 80 °F	18 to 27 °C
G	45 to 96 °F	7 to 35 °C
J	68 to 78 °F	20 to 26 °C
K	65 to 95 °F	18 to 35 °C
L	70 to 74 °F	21 to 23 °C
P	-2 to +2	-2 to +2
X	40 to 80 °F	4 to 27 °C

H = Relative Humidity Range	
Designator	%RH
M	0 to 100
N	35 to 70

G = Connection Configuration	
Designator	Type
CG	Common Ground
DF	Differential Ground

EXAMPLE																
<b>BA/BS3</b>	<b>F</b>	<b>2</b>	<b>0</b>	<b>C</b>	<b>-10</b>	<b>M</b>	<b>-24</b>	<b>C</b>	<b>80</b>	<b>CG</b>	<b>-61</b>	<b>CG</b>	<b>-102</b>	<b>-C35L</b>	<b>-TB</b>	<b>-GRY</b>
Example Part Number: BA/BS3F2-0C-10M-24C80CG-61CG-102-C35L-TB-GRY																
<b>Your Part Number:</b>																

All ranges and options may not be shown here, call BAPI for additional options or with questions about this ordering grid  
 \* Channel 1 or 2 are Common Ground  
 \*\* Test & Balance is only available with Direct Sensor Type Output  
 \*\*\*Must use a 10K-2 thermistor for the External Sensor option. Thermistor is purchased separately. (25' max) This option is only available on units without humidity