

Air Quality Sensors

Rev. 08/13/10

Features & Options

- Long Life Electrochemical Sensor
- High Accuracy at Low Concentrations
- Optional LCD Display
- Rugged Housing with Mounting Tabs for Easy Installation
- Two Year Warranty

BAPI's Carbon Monoxide Sensor offers enhanced, long life electrochemical sensing with outstanding accuracy at low concentrations. The sensor has a range of 1-100 PPM or 1-300 PPM of Carbon Monoxide with a resolution of 1 PPM and a linear output of 4-20 mA. The unit also features a robust enclosure and is available with or without LCD display.



Carbon Monoxide Sensor with Display



Carbon Monoxide Sensor without Display

Ordering Information: Carbon Monoxide Sensor/Transmitter				
BA/420CO	4 - 20mA output Carbon Monoxide Sensor/Transmitter			
	Carbon Monoxide Concentration			
	-1	1 - 100 ppm Carbon Monoxide		
	-3	1 - 300 ppm Carbon Monoxide		
	LCD Display			
	-ND	No Display		
	-D	LCD Display		
	Case Style			
	-EUO	UV-Resistant Plastic		
	Mounting Kits (Optional)			
	-FM	3/4" Conduit Adapter only		
	-PM	Panel Mount		
EXAMPLE				
BA/420CO	-1	-D	-EUO	-FM
Example Part Number: BA/420CO-1-D-EUO-FM				
Your Part Number:				

Specifications

Range: 1-100 PPM CO (normal range) or 1-300 PPM CO (optional)

Voltage requirement: 12-27 VDC (non-display) or 14-27 VDC (with display)

Signal output: 4-20 mA, 2-wire, loop powered

Sensor type: Electrochemical cell

Enclosure Material: UV-resistant plastic

Resolution: 1 PPM on display,
Infinite on 4-20 mA loop

Accuracy: ±5 PPM (combination of linearity,
temperature, drift and repeatability)

Response time:
90%: Less than 40 seconds @ 25°C

Environmental Operating Range:

Temperature: -20°C to 40°C (non-display)
-10°C to 40°C (with display)

Humidity: 15-90% RH (constant)
0-98% RH (intermittent)

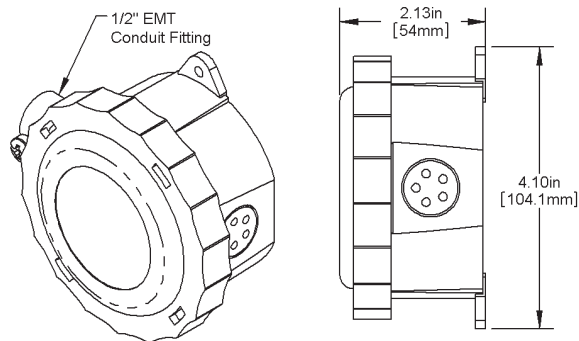

Carbon Monoxide Sensor

Sensor life expectancy: More than four years

Load Resistance: 500 Ohms max at 24 VDC

* BAPI recommends that you do not run wiring for the CO transmitter in the same conduit as line voltage wiring or with wiring used to supply highly inductive loads such as motors, generators, and coils.



Carbon Monoxide Sensor **D13**

Air Quality Sensors

Rev. 08/13/10

Datasheets without List Prices are available on our website at www.bapivac.com

Ordering Information: Carbon Monoxide Sensor/Transmitter						List Price	Your Order
BA/420CO	4 - 20mA output Carbon Monoxide Sensor/Transmitter					\$400	\$ _____
Carbon Monoxide Concentration							
-1	1 - 100 ppm Carbon Monoxide						
-3	1 - 300 ppm Carbon Monoxide						
LCD Display							
-ND	No Display						
-D	LCD Display						
Case Style							
-EUO	UV-Resistant Plastic						
Mounting Kits (Optional)							
-FM	3/4" Conduit Adapter only						
-PM	Panel Mount						
EXAMPLE						\$90	\$ _____
BA/420CO	-1	-D	-EUO	-FM			
Example Part Number: BA/420CO-1-D-EUO-FM							
Your Part Number:						Total =	\$ _____

Gray shaded items follow the Buy and Resale Multiplier.