

Washdown Wall Plate Unit

Humidity & Combination Temp/Humidity Sensors

Rev. 07/08/08



Non Protruding Sensor and Filter, Perfect for Vivarium Laboratories

Features & Options

- Stainless Steel, Water Tight Wall Plate Unit
- Flush to the Wall with No Filter to Replace
- $\pm 2\%$ RH Accuracy, $\pm 0.3\%$ Temperature Accuracy
- Choice of Outputs with Analog Output Modules (see pgs B19-21)
(4-20 mA, 0-5 VDC, 0-10 VDC or 10K-2 or 10K-3 Thermistor)
- Direct Temperature Sensor (optional)
- Splash-proof Pushbutton Override with or without LED (optional)



**Washdown
Wall Plate Unit**



The Washdown Wall Plate Unit is available as a humidity sensor alone or as a combination temperature and humidity sensor. The 304 stainless steel plate and sensor are water tight for washdown or wipedown areas. A 1/8" closed cell foam pad insulates the sensors from the wall temperature and seals the wall to prevent air leaks.

The unit is also available with a water resistant Pushbutton Override (with or without LED indicator), or a separate Direct Temperature Sensor (for controllers which require a specific thermistor, RTD, semiconductor or temperature transmitter).

Washdown Wall Plate Power Supply and Analog Output Modules

A Washdown Wall Plate Power Supply provides power to the Wall Plate as well as to the Analog Output Modules which convert the temperature and humidity data from the Wall Plate into a resistance, voltage or current signal for the DDC controller. One Power Supply can support up to 15 Wall Plates and 30 Output Modules. The optional Direct Temperature Sensor doesn't require an Analog Output Module. See the next four pages for more Info on the Power Supply and Output Modules.

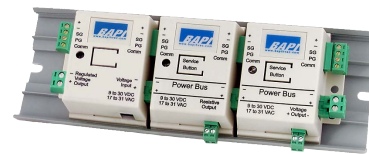

**Washdown Wall Plate
Power Supply with two
Output Modules**

Specifications

Power: From Washdown Power Supply only (See page B18)

Power Consumption:

- 0.5 mA max. DC with 1 Wall Plate Unit attached
- 10 mA max. DC with 15 Wall Plate Units attached

Sensing Elements:

- Temp. - Semiconductor Band Gap, Proportional to Absolute Temperature, $\pm 0.3^\circ\text{C}$
- Humidity - Capacitive Polymer, $\pm 2\%$ RH Accuracy
- Optional Direct Temp. Sensor - Therm., RTD or Semicond.

Wiring: 3 to 5 pair (depending upon options), 16 to 22 AWG*.

Environmental Operation Range:

- Temp: -30°C to 70°C
- Humidity: 0% to 100% RH, non-condensing

Mounting: Standard 2" by 4" J-box - mounting screws provided

Material: Stainless Steel

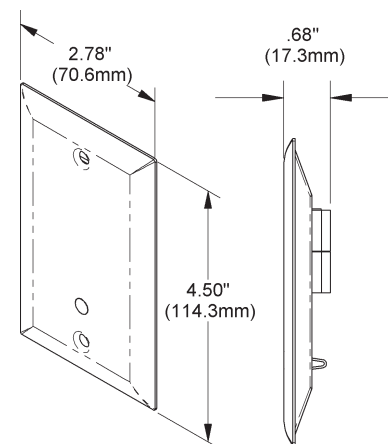

* BAPI recommends that you do not run wiring for the Wall Plate Unit in the same conduit as line voltage wiring or with wiring used to supply highly inductive loads such as motors, generators, and coils.

Rev. 07/08/08

Ordering Information		Washdown Wall Plate Units	
BA/SPV			
Optional Override Pushbuttons		<i>Requires Doublegang Plate</i>	
-O2	Low Profile Style Pushbutton Override		
-O2G5	Low Profile Pushbutton Override, Green LED, 5 VDC ¹		
-O2G24	Low Profile Pushbutton Override, Green LED, 24 VDC or VAC ¹		
-O2R5	Low Profile Pushbutton Override, RED LED, 5 VDC ¹		
-O2R24	Low Profile Pushbutton Override, RED LED, 24 VDC or VAC ¹		
Optional Direct Temperature Sensors		<i>Requires Doublegang Plate</i>	
-0	100 Platinum RTD, 100 Ω @ 0 °C, 0.385 Ω/°C temp. coeff.		
-0[3W]	3 Wire 100 Platinum RTD, 100 Ω @ 0 °C, 0.385 Ω/°C temp. coeff.		
-1375	1K Platinum RTD, 1,000 Ω @ 0 °C, 3.75 Ω/°C temp. coeff.		
-1NI	1K Ω Nickel @ 21°C, 5 Ω/°C temp. coeff.		
-1	1K Platinum RTD, 1,000 Ω @ 0 °C, 3.85 Ω/°C temp. coeff.		
-2	2K Silicon RTD, 2,000 Ω @ 20 °C, 8 Ω/°C temp. coeff.		
-18	1.8K Thermistor, 1,800 Ω @ 25 °C		
-3	3K Thermistor, 3,000 Ω @ 25 °C		
-33	3.3K Thermistor, 3,300 Ω @ 25 °C		
-102	10K-2 Thermistor, 10,000 Ω @ 25 °C		
-103	10K-3 Thermistor, 10,000 Ω @ 25 °C		
-10311	10K-3(11K) Thermistor, 5,238 Ω @ 25 °C, 11kΩ shunt resistor		
-20	20K Thermistor, 20,000 Ω @ 25 °C		
-50	50K Thermistor, 50,000 Ω @ 25 °C		
-100	100K Thermistor, 100,000 Ω @ 25 °C		
334	LM334 Semiconductor		
-592	AD592 Semiconductor, 273 μA @ 0 °C		
592-10K	AD592 Semicond. w/ 10 kΩ shunt resistor, 2.73 V @ 0C		
T100[range³]	100 Platinum RTD, 100 Ω @ 0 °C with 4 to 20 mA Transmitter Output		
T1K[range³]	1K Platinum RTD, 1,000 Ω @ 0 °C with 4 to 20 mA Transmitter Output		
Doublegang Wall Plate		<i>Required for any option other than SPV</i>	
-DBG	Doublegang Wall Plate		
Security Screws			
-SEC1	Spanner Security Screws ²		
EXAMPLE			
BA/SPV	-O2		-DBG
Example Part Number: BA/SPV-02-P01-DBG			
Your Part Number:			

Call BAPI if you have questions about the above ordering grid or the configuration of the product you are ordering.
 The Optional Direct Temperature Sensors do not require an Analog Output Module
¹Voltage to power the LED indicator (5 VDC or 24 VDC or VAC) must come from the controller or other external source.
²Security Screws require a Spanner Bit (see Accessories Section)
³Custom Ranges are available. Contact your BAPI representative for more information on Ranges

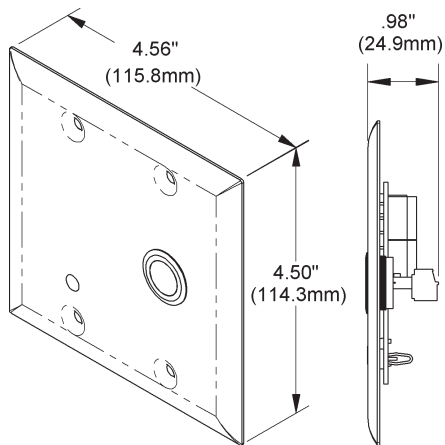

Doublegang Wall Plate with Pushbutton Override
 (A doublegang wall plate is required for units with a pushbutton override or a separate direct temperature sensor.)